

1972

Synthetic routes to heterocycloheptatrienes

Albin James Nelson
Iowa State University

Follow this and additional works at: <https://lib.dr.iastate.edu/rtd>

 Part of the [Organic Chemistry Commons](#)

Recommended Citation

Nelson, Albin James, "Synthetic routes to heterocycloheptatrienes" (1972). *Retrospective Theses and Dissertations*. 5945.
<https://lib.dr.iastate.edu/rtd/5945>

This Dissertation is brought to you for free and open access by the Iowa State University Capstones, Theses and Dissertations at Iowa State University Digital Repository. It has been accepted for inclusion in Retrospective Theses and Dissertations by an authorized administrator of Iowa State University Digital Repository. For more information, please contact digirep@iastate.edu.

INFORMATION TO USERS

This dissertation was produced from a microfilm copy of the original document. While the most advanced technological means to photograph and reproduce this document have been used, the quality is heavily dependent upon the quality of the original submitted.

The following explanation of techniques is provided to help you understand markings or patterns which may appear on this reproduction.

1. The sign or "target" for pages apparently lacking from the document photographed is "Missing Page(s)". If it was possible to obtain the missing page(s) or section, they are spliced into the film along with adjacent pages. This may have necessitated cutting thru an image and duplicating adjacent pages to insure you complete continuity.
2. When an image on the film is obliterated with a large round black mark, it is an indication that the photographer suspected that the copy may have moved during exposure and thus cause a blurred image. You will find a good image of the page in the adjacent frame.
3. When a map, drawing or chart, etc., was part of the material being photographed the photographer followed a definite method in "sectioning" the material. It is customary to begin photoing at the upper left hand corner of a large sheet and to continue photoing from left to right in equal sections with a small overlap. If necessary, sectioning is continued again — beginning below the first row and continuing on until complete.
4. The majority of users indicate that the textual content is of greatest value, however, a somewhat higher quality reproduction could be made from "photographs" if essential to the understanding of the dissertation. Silver prints of "photographs" may be ordered at additional charge by writing the Order Department, giving the catalog number, title, author and specific pages you wish reproduced.

University Microfilms

300 North Zeeb Road
Ann Arbor, Michigan 48106
A Xerox Education Company

73-3918

NELSON, Albin James, 1946-
SYNTHETIC ROUTES TO HETEROCYCLOHEPTATRIENES.

Iowa State University, Ph.D., 1972
Chemistry, organic

University Microfilms, A XEROX Company, Ann Arbor, Michigan

THIS DISSERTATION HAS BEEN MICROFILMED EXACTLY AS RECEIVED.

Synthetic routes to heterocycloheptatrienes

by

Albin James Nelson

A Dissertation Submitted to the
Graduate Faculty in Partial Fulfillment of
The Requirements for the Degree of
DOCTOR OF PHILOSOPHY

Department: Chemistry

Major: Organic Chemistry

Approved:

Signature was redacted for privacy.

In Charge of Major Work

Signature was redacted for privacy.

For the Major Department

Signature was redacted for privacy.

For the Graduate College

Iowa State University
Ames, Iowa

1972

PLEASE NOTE:

Some pages may have
indistinct print.

Filmed as received.

University Microfilms, A Xerox Education Company

TABLE OF CONTENTS

	Page
DEDICATION	iii
A NOTE ABOUT NOMENCLATURE	iv
THEORETICAL ASPECTS	1
APPROACHES TOWARD SYNTHESIS, LITERATURE METHODS	20
PHOTOCHEMISTRY OF HETEROCYCLOPENTADIENES THE RELATION OF STRUCTURE TO REACTIVITY	33
Photodimerization and aromaticity	33
Cycloaddition to silole <u>1</u>	60
Synthesis of a silepin from initial photocycloaddition	65
Photoadditions to a silacyclopentene (<u>24</u>)	103
DIELS-ALDER REACTIONS OF HETEROCYCLOPENTADIENES	108
RING CLOSURE USING SULFUR DICHLORIDE	138
EXPERIMENTAL	171
General Information	171
REFERENCES CITED	222
ACKNOWLEDGEMENTS	234
APPENDIX	235

DEDICATION

This thesis is dedicated to the
memory of my grandfather

Albin James Nelson

who told me never to fish
in the middle of the lake.

A NOTE ABOUT NOMENCLATURE

Two systems of nomenclature are prevalent in the literature of heterocyclic organic chemistry. The first treats all heterocycles as a perturbation of the all-carbon system. The number of the position and the name of the heteroatom is then added to the carbo-name in the same place a substituent would be put. Thus the molecule drawn below is 1-methyl-1-azacycloheptane.

The other system has special names for unsaturated heterocycles and treats the saturated compounds as perturbations of the unsaturated ones. The ending on the root name indicates the degree of unsaturation. Further, the root name changes depending on the presence of nitrogen. Some common roots are ole, for an unsaturated five membered ring, epin, for an unsaturated seven membered ring, enon, for an unsaturated nine membered ring. Ete and an are the roots for four and six membered rings respectively. 1,1-dimethylsilepin is shown below.

In the interest of space economy, the shortest name will always be employed in this work. In addition, a general name such as heterocyclopentadienes will be understood to mean a five membered ring with four carbons and one heteroatom. Possession of more than one heteroatom by a ring will be explicitly stated (there are only three in this thesis).

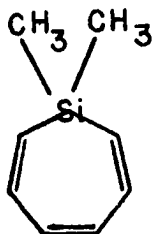

1,1-dimethylsilepin



1-methyl-1-azacycloheptane

The interested reader may refer to any of the current books about general organic chemistry for more nomenclature rules. A good one is J. D. Roberts and Marjorie C. Caserio, "Basic Principles of Organic Chemistry", W. A. Benjamin, New York, 1965. Look on page 969.

LIST OF FIGURES

Figure	Title	Page
1	Orbital symmetry diagram for silepin	10
2a	60 MHz NMR spectrum of a mixture of silole <u>1</u> and dimer <u>2</u>	40
2b	60 MHz NMR spectrum of pure dimer <u>2</u>	40
3	Crystal structure of silole dimer <u>2</u>	42
4a	60 MHz NMR spectrum of phosphole dimer <u>9</u>	46
4b	60 MHz NMR spectrum of germole dimer <u>6</u>	46
5	Crystal structure of pyrrole <u>7</u>	53
6	Crystal structure of phosphole <u>8</u>	55
7	Crystal structure of silole <u>1</u> monomer	59
8a	60 MHz NMR spectrum of phosphole-silole dimer <u>11</u>	64
8b	60 MHz NMR spectrum of silole-maleic anhydride Diels-Alder adduct <u>25</u>	64
9	Plot of $1/[1]$ vs. time	68
10a	60 MHz NMR spectrum of expanded middle region	73
10b	60 MHz NMR spectrum of adduct <u>13</u>	73
11a	60 MHz NMR spectrum of isolated mesylate isomer <u>18-1</u>	84
11b	60 MHz NMR spectrum of the mixture of benzoates <u>17</u>	84
12a	60 MHz NMR spectrum of 1,1-dimethyl-2,7-diphenylsilepin <u>19</u>	90
12b	100 MHz NMR spectrum of <u>19</u>	90
13a	60 MHz NMR spectrum of adduct <u>28</u> and the decomposition intermediate	116

13b	60 MHz NMR spectrum of <u>28</u> , the silole-dichlorovinylene carbonate adduct	116
14	Crystal structure of siloxapinone <u>33</u>	123
15	60 MHz NMR spectrum of a mixture of <u>29</u> and <u>1</u> at <u>ca.</u> -50°C	132
16	60 MHz NMR spectrum of C ₂₂ H ₁₃ SCl	143
17	Crystal structure of adduct <u>50</u>	147
18	Crystal structure of <u>61</u>	156

LIST OF TABLES

Table		Page
1	UV Spectra of Some Heterocyclopentadienes	50
2	UV Spectra of <u>60</u> and <u>77</u>	151
3	Bond Distances of <u>63</u>	157
4	Bond Angles of <u>63</u>	158
5	Extent of the Silole Photolysis Reaction	183

THEORETICAL ASPECTS

The cycloheptatriene model

Cycloheptatriene exists as two rapidly interconverting boat conformers. F. A. L. Anet¹ found the rate inversion to be 180 sec.^{-1} calculated from low temperature NMR studies at -150°C .

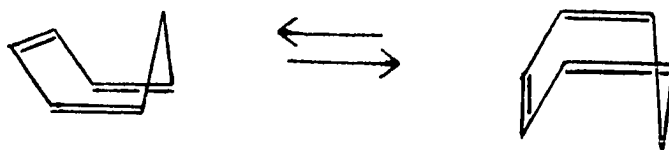

The energy of activation is $6.3 \pm 0.5 \text{ kcal/mole}$. Substitution around the cycloheptatriene ring raises the barrier of inversion quickly. Conrow² found the coalescence temperature of 1,1,3-trimethyl-2-*t*-butyltropyliidene to be -86°C . Phenyl substitution raises the coalescence temperature even more. Barton³ found 2,3,4,5-tetraphenyltropyliidene coalesced at 38°C . An X-ray structure of *p*-bromobenzyl-1,1-dimethyl-4-carboxy-2,4,6-cycloheptatriene ester⁴ revealed the ring puckering to be 23.7° and 49.7° . This cycloheptatriene has a typical carbon-carbon double bond distance of 1.33 \AA .

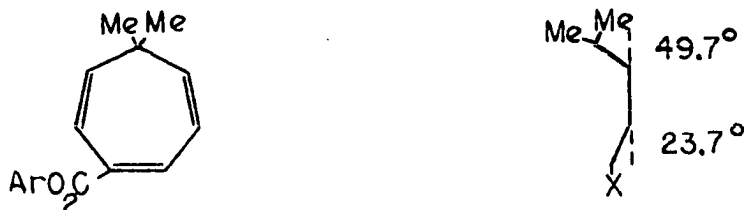

These studies and others like them put to rest any controversy in describing cycloheptatriene either as a planar system or as a homoaromatic one.

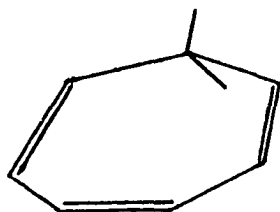

PLANAR

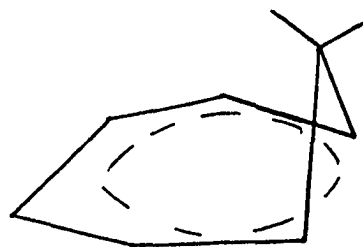

HOMOAROMATIC

Removal of a hydride ion from cycloheptatriene creates a planar system having seven atomic "p" orbitals available for an aromatic molecular orbital system with six electrons. Various authors have adequately described the molecular orbital scheme including Streitwieser⁵ and Dewar⁶. Dewar has calculated the aromatic energy, E_{ar} , for the tropylium cation⁶ to be 0.93 eV. or 21.4 kcal/mole as compared to the open chain ion. For comparison cyclopropenium cation has an effective pi-bonding energy (E_{ar}) of 1.84 eV. or 42.4 kcal/mole by Dewar's method.

Experimental fact corroborates the stability of the tropylium cation. Pyrolysis of the 1,6 bromine addition product of cycloheptatriene gave tropylium bromide⁷. The synthesis of tropylium iodide is such a sure-fire procedure

that it is included in undergraduate laboratory preparations⁸. Spectroscopic investigations of the cation⁹ demonstrate the correlation between the calculated energy levels for a planar aromatic molecule and the ultraviolet absorptions.

The cycloheptatrienyl anion may be contrasted with the cation. It is a $4n$ pi electron system having a relative aromatic energy¹⁰ of 10.25 eV. or -5.78 kcal/mole as compared to the heptatrienyl anion. This destabilization makes the anion at least an unobserved system. Thus, the cation and anion of cycloheptatriene fit the classic Hückel $4n+2$ rule where the cation is predicted to be aromatic with 6 pi electrons and the anion antiaromatic with 8 pi electrons.

Heterocycloheptatrienes, the borepin, an example

Substitution of a heteroatom for the saturated carbon of cycloheptatriene should produce dramatic changes in its electronic character reminiscent of the tropylium cation and anion. The borepin is an example of a system fitting the Hückel rule. It has available a vacant "p" orbital for conjugation with the triene system. Its electronic character should be close to that of the tropylium cation. However, molecular orbital calculations on heteroatom systems become difficult because of the polar nature of the heteroatom-carbon bond. This polar nature negates the assumption in Hückel or Pople SCF calculations that the sigma framework is an assemblage of atoms each carrying an integral charge¹¹.

VanTamelén¹² has synthesized 1-phenyl-2,3:6,7-dibenzoborepin and found it to be quite stable. The 1-phenyl-4,5-benzoborepin¹³ has also been synthesized. Both compounds were stable to air exposure, a kiss of death for many boron compounds, proving the unique stability.

Heterocycloheptatrienes, the silepin, a goal

Silicon containing molecules often exhibit pi bonding resulting from (d-p) orbital overlap. Cotton and Wilkinson¹⁴ have discussed such bonding in silicon tetrafluoride. In this case best overlap occurs between filled "p" orbitals of fluorine and the $d_{x^2-y^2}$ orbital of silicon. A three dimensional view of the bonding may be drawn. However, two of the fluorines will be omitted for clarity.

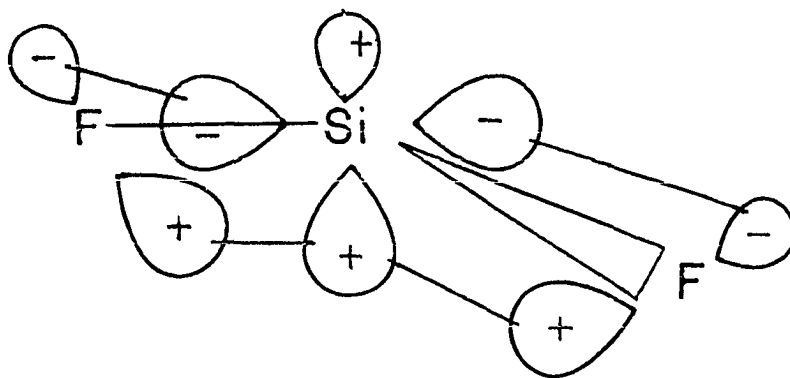

Physical evidence supports this picture. The bond lengths of silicon tetrafluoride, even after ionic-covalent resonance is taken into account, are shorter by 0.13 \AA than expected¹⁵.

The (d-p) pi bond shows the same directionality as a (p-p) sigma bond and may be contrasted to (p-p) pi bonds. Movement of atoms one and three in the plane defined by atoms one, two and three has no effect on the overlap of the (p-p) pi bond.

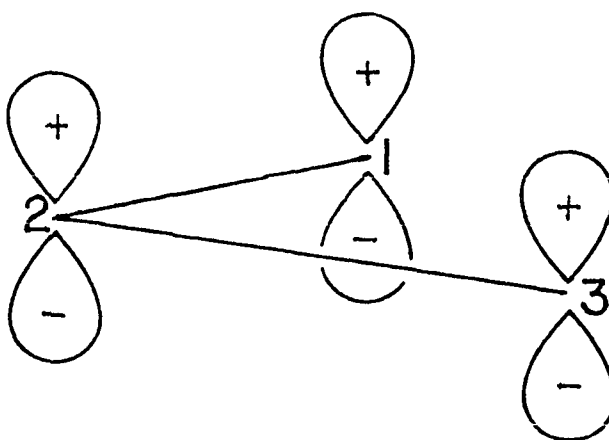

If the orbital on atom two becomes a "d" orbital, then directionality is shown.

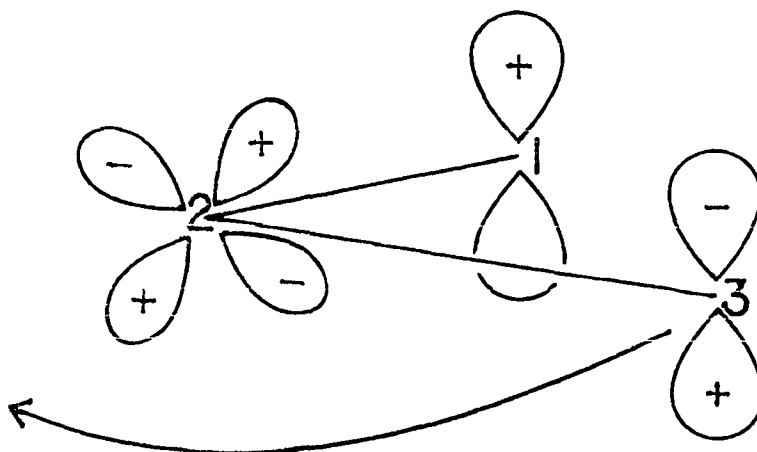

In this case best overlap occurs when the angle 1-2-3 is 180° ¹⁶.

How may the geometry of (p-d) pi conjugation be applied to silylorganic systems? Such conjugation in 1-silacycloheptatriene (silepin) may occur by two types, (1) conjugation of the pi orbitals of the olefin fragment with the d_{z^2} or $d_{x^2-y^2}$ orbitals, or (2) with d_{xy} , d_{xz} or d_{yz} . Although the first type of conjugation was favorable in silicon tetrafluoride, it becomes unfavorable in unsaturated organosilanes because of nonbonded interaction.

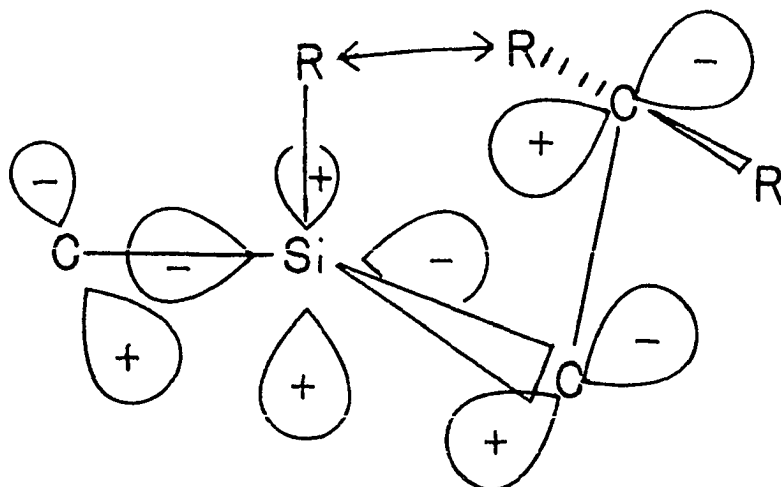

The second type is the bonding picture most often presented. However, it suffers from the directionality that "d" orbitals maintain in pi bonding. The silicon cannot be tetrahedral and have maximum (d_{xz} -p) overlap with both

olefin fragments at the same time. To do so would require a carbon-silicon-carbon bond angle of 180° .

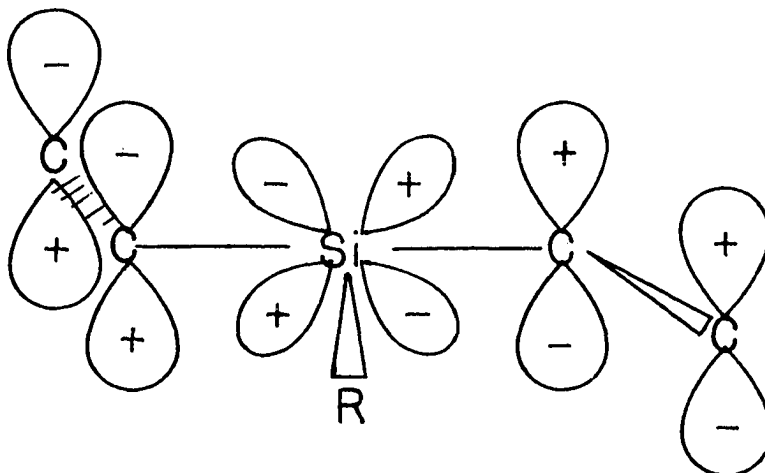

Conjugation may occur with different "d" orbitals, also.

However, this broken conjugation will not provide the silepin complete around-the-ring delocalization necessary if it is to gain stability analogous to the tropylium cation.

The correct symmetry of triene interaction with the "d" orbitals of silicon is also a necessary requirement in any silepin bonding scheme. Ebsworth has discussed (p-d) pi bonding¹⁷ in terms of the symmetry of molecular structure. Relevant to this discussion is his distinction between two types of organic ligands S and E' which are attached to the silicon atom. The S type ligands are those whose pi bonds are symmetric about the Si-C bond such as $-C\equiv N$ and $-C\equiv C-R$. For the E' ligands such as vinyl and phenyl, pi interactions will depend on the relative orientations of the "d" orbitals of silicon and the nodal planes of the substituent groups.

"...For $MR_2E'_2$, MRE'_3 and ME'_4 , the overall pi bonding depends on the orientation..., in particular, co-operative effects in electronic spectra (one method to observe the pi effects) would be expected only if there were a substantial barrier to rotation of the substituents. If the rotation of E' groups were relatively free about the $M-E'$ bond, then the pi interactions between E' and M will be relatively restricted."¹⁸ It is fortunate that Ebsworth provides such a solid qualitative view of the overlap extent in his discussion but he does not comment on the quantitative extent; it might be a minor perturbation.

Specific molecular orbital interactions of the silepin may be diagrammed like any M. O. scheme. That mixing diagram is given in Figure 1. Sigma 1 is a mirror plane through the carbon nuclei perpendicular to the carbon "p" orbitals. Sigma 2 is parallel to the carbon "p" orbitals and bisects the C_3-C_4 bond.

It is apparent that at least symmetry will allow (d-p) pi interaction. But what can be said of the amount of overlap? Is the silepin riding upon a troyelephant of interaction? Or is the ride more like that on a paper dragon, a fragile, sometime thing.

Schweig¹⁹ discussed through conjugation in a quantitative manner and his concept of it in his paper "Through Conjugation Through a Tetrahedral Silicon Atom." He

Figure 1. Orbital symmetry diagram for silepin

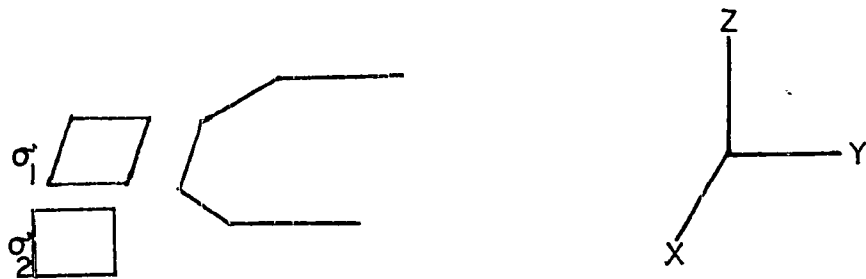

Triene

Silicon

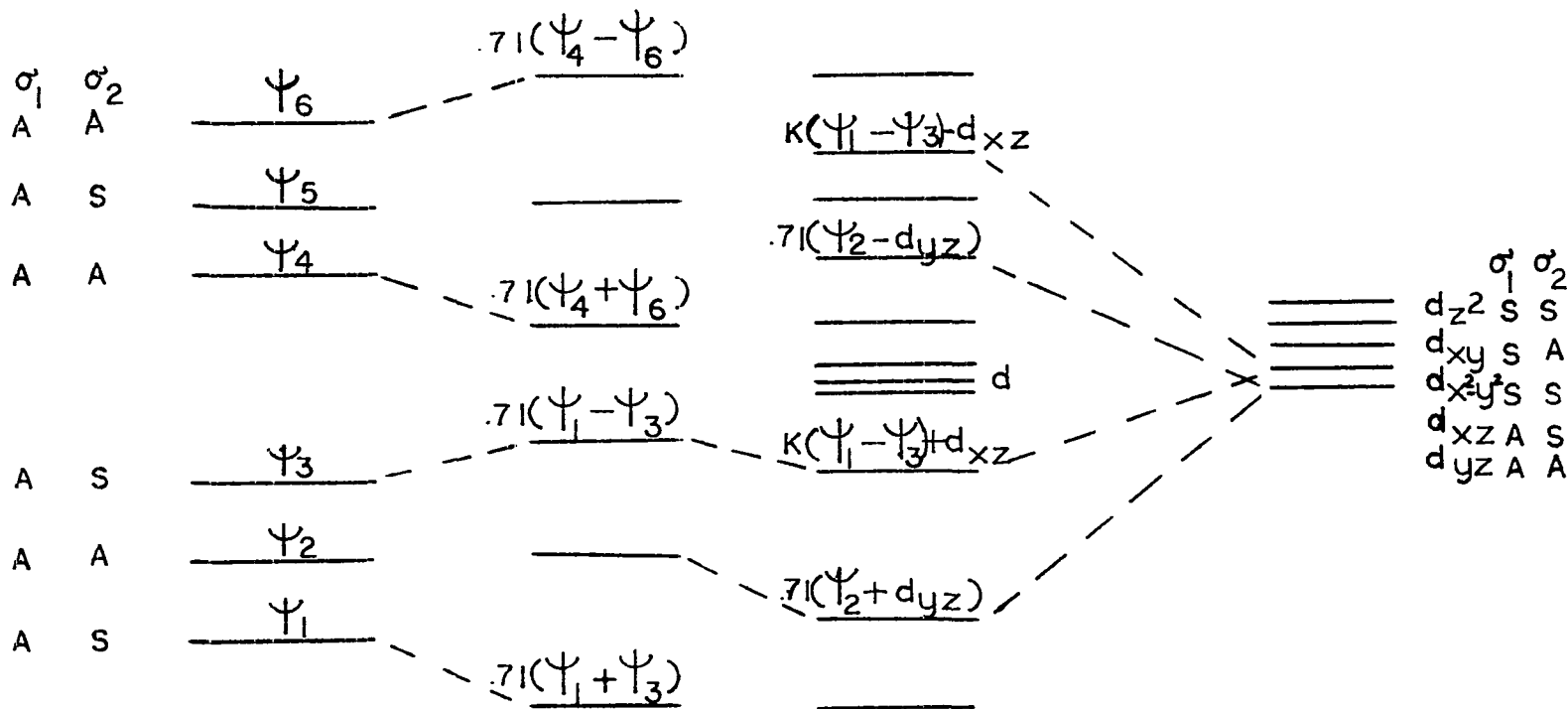

constructed a "d-pi" atomic orbital on the silicon of divinylsilane. The lobes of this orbital coincide with the C_2 axis. He stated, "This A. O. may be regarded as being built up by a linear combination of two "d"-pi A. O.'s²⁰ each directed along one Si-CH bond." He thus conceives the required (d-p) bonding as resulting from the interaction of the d_{yz} silicon orbital with the two olefin fragments. This picture is a valid one, but omits the contribution from the d_{xz} silicon orbital.

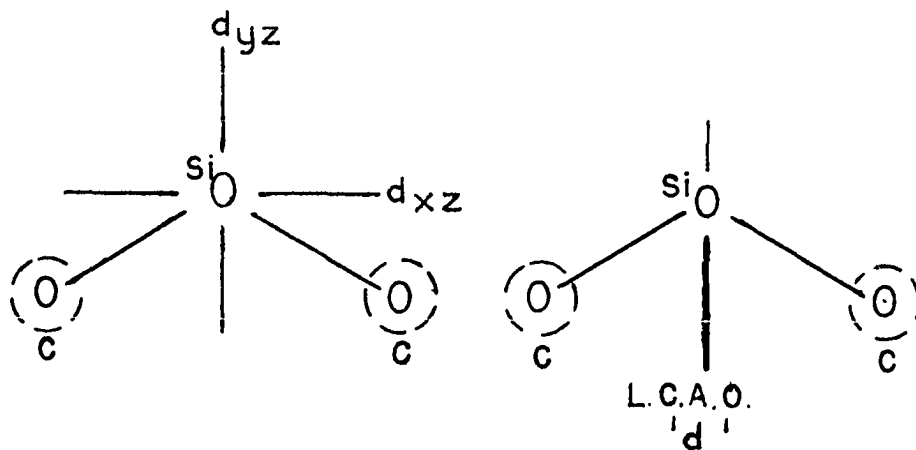

Silepin, divinylsilane and tetravinylsilane all have the proposed through-conjugation scheme in common. Therefore, a determination of such phenomena in one molecule of this set generates a firm basis for such a phenomena in the rest. A convenient method for determination of the molecular orbital energies of covalent bonded molecules is photoelectron spectroscopy. Schweig has analyzed the photoelectron spectra¹⁹ obtained from vinylsilane, divinylsilane and tetravinylsilane. A comparison of the H.O.M.O. of these molecules

should produce a striking result, if indeed through-conjugation has substantive reality. Schweig found the H.O.M.O. to be 9.8 eV. for all of the examined molecules. He stated, "The effects of "d" pi conjugation in vinylsilane and of "d" pi through-conjugation in divinylsilane have the same magnitude." This statement, based on his constructed M. O.'s was supported by the P.E. observation. He concluded, "Through-conjugation through a tetrahedral silicon atom does exist." However, if the simple comparison of the vinyl, divinylsilane set to the allyl, pentadienyl cation set is made, it is obvious that the H.O.M.O.'s should be of a different energy. Simple Hückel calculation shows the following M. O. energies. The energy difference between the

CYCLOPENTADIENYL		ALLYL	
X ₁	$\alpha - 1.732\beta$	X ₁	$\alpha - 1.414\beta$
X ₂	$\alpha - \beta$	X ₂	α
X ₃	α	X ₃	$\alpha + 1.414\beta$
X ₄	$\alpha + \beta$		
X ₅	$\alpha + 1.732\beta$		

H.O.M.O.'s is 0.324 eV. or 7.45 Kcal/mole. If the difference between Si-d and C-p orbitals plus the longer bond length of Si-C decreased the energy difference by as much as 70% or 0.226 eV., ca. 0.1 eV. is still a recognizable difference in the P.E. spectrum. Schweig's M. O. calculations might clear

this discrepancy or misconception; however, they have not as yet been published.

From the above discussion, some authors feel through-conjugation in silane systems is present. However, use of both the d_{yz} and d_{xz} creates an argument for stability based upon conjugation of the unsaturated fragment with different "d" orbitals on the silicon. Dewar, Lucken and Whitehead²¹ have considered (d-p) pi bonding in phosphonitrilic halides of the general formula $(PNCl_2)_n$. Keeping in mind that the same bonding picture may be used for organosilanes like silepin and divinylsilane, Dewar's argument is presented. Craig had calculated pi M. O.'s using the d_{xz} orbital of phosphorus and found complete conjugation much like that of benzene. However, Dewar pointed out that calculation was not valid because the d_{yz} orbital was not used. He then constructed a new set of orthogonal orbitals out of those in a favorable position for overlap, namely, the dxz and the dyz . This new set has each orbital directed roughly along the P-N sigma bond axis. An LCAO of the new set of "d" pi orbitals on phosphorus and the "p" orbital on nitrogen gives three center (N-P-N) M. O.'s which overlap only very weakly with each other. There is no complete, unbroken conjugation around the ring. However, the bond lengths are the same because the N's of the three center M. O. (P-N-P) are linked to both P's with equally strong pi bonds. Dewar stated, "The compound

is not aromatic in the benzene sense, but resonance energy is maintained."

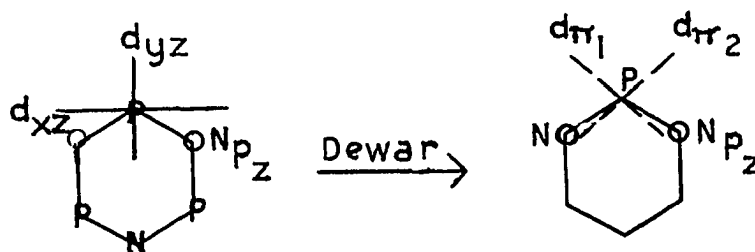

The "d" pi orbital combination of Dewar's may be used in considering the silepin. Through-conjugation should not then play an important part in resonance stabilization. However, there is still delocalization of the triene system into the silicon atom. But it is not required to become planar with the triene fragment to achieve such overlap. Such a bonding picture is in direct contrast to that presented by Schweig.

Construction of the same "d" pi type orbitals allows Longuet-Higgins²² to comment on the stability of thiophene. He made an LCAO from the $3p_z$, $3d_{xz}$ and $3d_{yz}$ orbitals of sulfur. The bonding picture is much like that of the phosphonitrile halides. The reorganization scheme is shown.

The orbital scheme for thiophene
postulated by Longuet-Higgins.

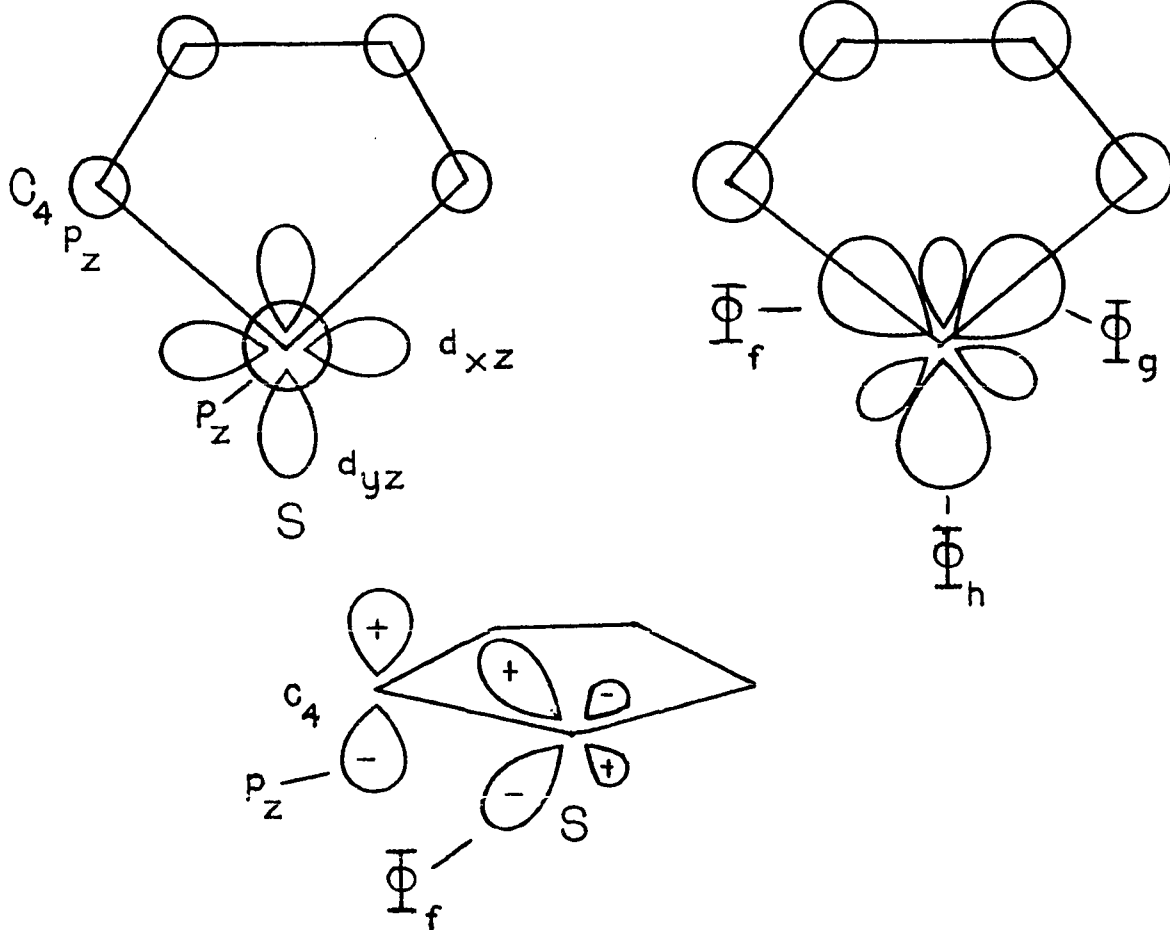

The availability of the 3d orbitals on sulfur as compared to oxygen and nitrogen is the factor which gives added stability to the thiophene according to Longuet-Higgins. Dewar's "d" pi orbitals were orthogonal and did not permit any complete conjugation. However, mixing of a "p" orbital, as in the above case, gives a system where the LCAO ϕ_f and ϕ_g are not orthogonal and through-conjugation does exist. Mixing of the proper 3"p" orbital of silicon in unsaturated silanes would have the same effect. The obvious point is, the bonding scheme involving "d" orbitals of silicon is like a marionette; it depends on who pulls the strings.

Many organic molecules do not maintain overlap which would require the electron density to be directed along the internuclear axis. The density of the sigma C-C bonds of cyclopropane is at an angle of 21° from the internuclear axis^{23,24}. The density region of cyclobutane is similar with an angle of 7°²³. Overlap of the bis-homocyclopropylation, 7-norbornenonium ion, has been calculated by Roberts^{25;26}. There is no chance for coplanarity of all three "p" carbon orbitals. However, considerable stabilization is given the carbonium ion due to interaction with the pi cloud. It is reasonable, then, to consider a bonding scheme for the silepin where maximum overlap is not maintained.

Overlap of the silicon dxz orbital in a pi bond formation with a Cp_z orbital may be shown to follow the cosine law (see appendix for derivation). The law may be written as $S_{12} = S_{\pi\pi} \cos \gamma$ where γ is the angle the d_{xz} orbital is displaced from the internuclear axis (the X axis) and $S_{\pi\pi}$ is the overlap integral at $\gamma=0^\circ$. If silicon in divinylsilane or silepin is considered tetrahedral, then the displacement γ of the silicon $3d_{xz}$ orbital from the internuclear axis will be $(180^\circ - 109.5^\circ)/2$ or 35.25° . If (d-p) pi interaction is significant when the $3d_{xz}$ orbital is directed down the internuclear axis of the carbon-silicon bond, then at a displacement of 35.25° from that axis, the overlap is still 81.4% of its original value. The conclusion reached is that skewed overlap of the $C2p_z-Si3d_{xz}-C2p_z$ orbitals, when the C-Si-C bond angle is 109.5° , still has 81.4% of the maximum overlap value at 180° and rehybridization may be dispensed with.

The "aromatic" stability of seven atom, six pi electron cyclic systems might provide an opportunity for observation of through-conjugation in a molecule such as the silepin. Several silepins have been reported including 1,1-diphenyl-3,-benzosilepin²⁷ and 1,1-dimethyl-2,3:6,7-dibenzosilepin²⁸. However, the presence of the benzo groups masks the ring double bonds making them benzene type bonds, not silepin. Birkofer²⁷ concluded somewhat ambiguously that (d-p) pi

interaction was present from infrared analysis. Barton²⁸ did not find any (d-p) pi interaction from U.V. comparison to the all-carbon analogue.

Other heterocycloheptatrienes

Azepin, oxepin and thiepin are molecules which may be compared to the cycloheptatrienyl anion. These molecules contain eight pi electrons in their pi bonding framework and according to Hückel's rule should be antiaromatic, or at least be rather unstable toward decomposition or rearrangement. Although the parent 1H-azepin is unknown, 1H, 3H and 4H azepin derivatives have been demonstrated by X-ray crystallography and NMR techniques to have boat conformations. They behave a polyenes and react in typical conjugated olefin fashion. Excellent reviews have been written about azepins. They are included here only for the sake of completeness^{29,30}.

Oxepins have proved a bit more difficult to synthesize than azepins. The parent system³¹ exists as a tautomeric mixture of benzene oxide and oxepin. NMR studies have shown^{30,32} the boat conformation preference by the oxepin in order to prohibit conjugation around the ring.

Thiepin has proved most elusive. Various authors^{33,34} have postulated its intermediacy in reactions of thiepin derivative precursors which led to sulfur extrusion products.

Dewar³⁵ has done CNDO calculations on thiepin derivatives and predicts alternating bond lengths. The parent molecule has a negative resonance energy.

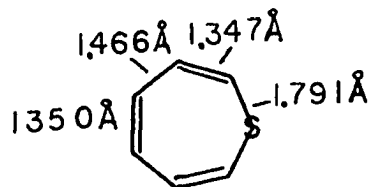

H_a	-58.7 eV.
E_r	-1.45 kcal/mole
I_v	8.01 eV.

As a comparison thiophene has a heat of atomization (calculated), H_a , to be -40.32 eV. and a resonance energy, E_r , of 6.5 kcal/mole. Its open chain analogue divinyl sulfide has a calculated heat of atomization of -44.54 eV. Dewar predicted the thiepin to be "antiaromatic with the negative resonance energy minimized by bond alternation."

APPROACHES TOWARD SYNTHESIS, LITERATURE METHODS

Methods for the synthesis of group IV heterocycloheptatrienes may be separated into categories whose members depend upon common building blocks. The short-march choice is the combination of two units whose sum of ring atoms equals seven. These units are listed according to number of atoms in the unit which actually combine to form the seven membered ring.

4 + 3 method

Addition of cyclobutadiene iron tricarbonyl³⁶ to Group IV heterocyclopropenes in the presence of some mild oxidizing agent seems a valid method to generate a Diels-Alder type reaction and form the heterocycloheptatriene directly.

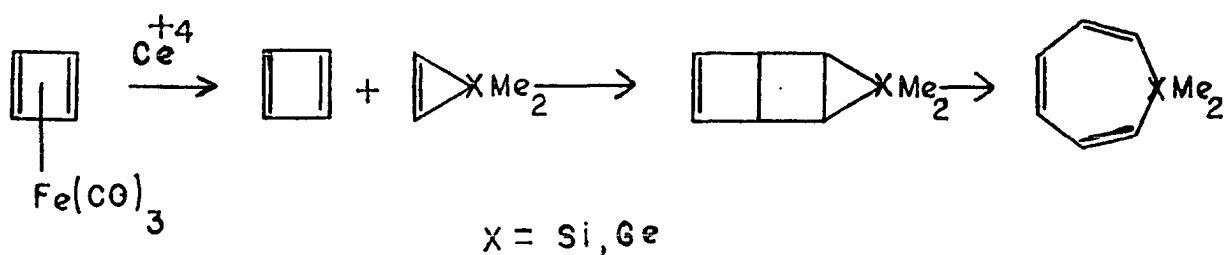

Cyclobutadiene generated in this manner is well-known³⁷ to undergo Diels-Alder reactions where it acts as the diene or as the dienophile. However, group IV heterocyclopropenes are unknown. Vol'pin^{38,39} reported the synthesis of

2,3-diphenyl-1-sila- and germacycloprop-2-enes and discussed the (d-p) pi bonding of such molecules. Later, workers in the field^{40,41} found both compounds to have molecular weights equal to the dimer based upon mass spectral and vapor phase osmometry data.

Another method for similar results is the addition of α -pyrone to heterocyclopropenes. Such a Diels-Alder addition product could undergo facile loss of CO_2 to give the heterocycloheptatriene directly. This attractive route is also despoiled by the instability and/or absence of heterocyclopropenes.

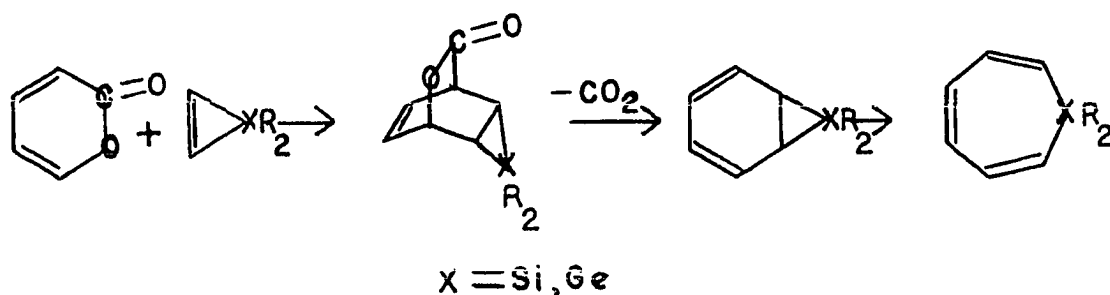

5 + 2 method

The 5 + 2 route is the most attractive one based upon the availability of starting materials. Thiophene, pyrrole and furan are well-known examples of very stable heterocyclopentadienes and their reactions with various reagents may have analogy in group IV heterocyclopentadiene chemistry.

Some other heterocyclopentadienes include 1,1-dimethyl-2,5-diphenylsilole⁴², 1,1-dimethylstannole⁴², the 2,3,4,5-tetraphenyl-1-heterocyclopentadienes⁴³ where the heteroatom is Au, Hg, Si, Sn, N, P, As, S, Se or Te. 2,5-diphenyltellurophene⁴⁵, tellurophene^{44,45}, selenophene derivatives⁴⁶ and 1,2,5-triphenylphosphole⁴⁷ are still others. Group IV heterocyclopentenes have also been synthesized including 1,1,3-trimethyl-1-silacyclopent-3-ene, 1,1-dimethyl-1-silacyclopent-3-ene and 1,1,3,4-tetramethyl-1-silacyclopent-3-ene^{48,49}.

Various schemes to make heterocyclopentadienes and pentenes may be drawn from the available literature. They are listed in order of heteroatom group.

Group IV

Braye method⁴³

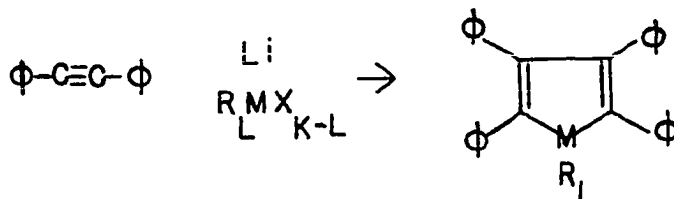

Gilman method⁴²

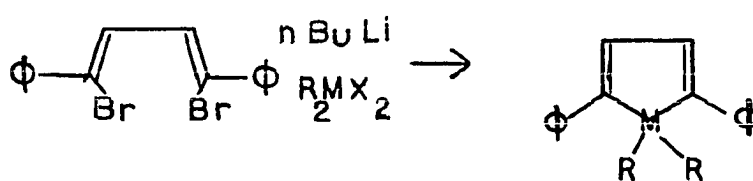

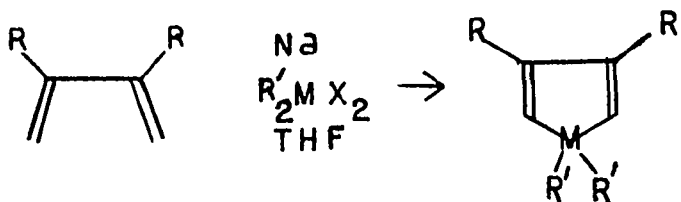
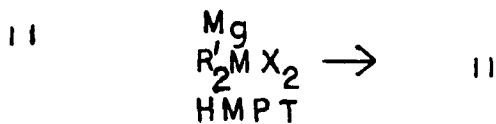
Weyenberg method⁴⁸Calas method⁴⁹

Group V

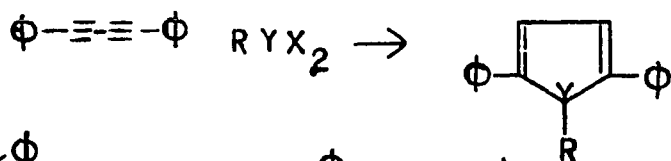
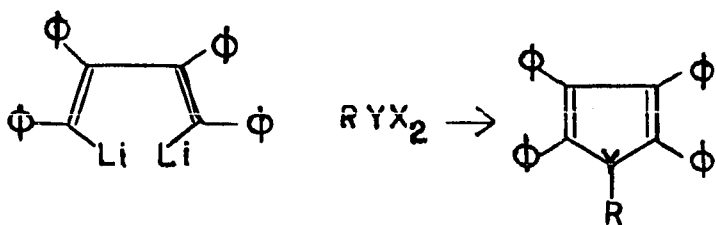
King⁵⁰ and Cookson⁴⁷ methodBraye⁴³ method

Of course, there are the classic synthesis methods such as the Paal-Knorr^{51,52} and the Knorr⁵³ pyrrole routes.

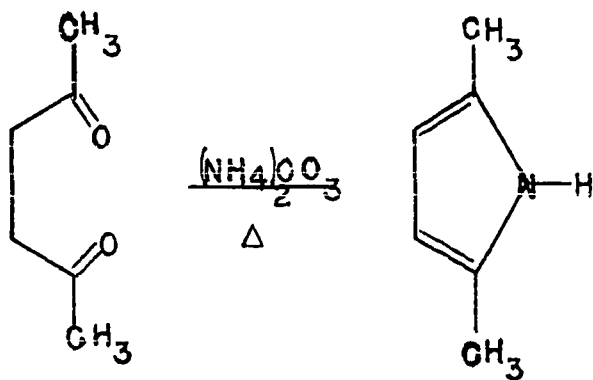

Group VI

The 1,4 addition of reagents to substituted butadiynes provides a facile route to thiophenes, tellurophenes and selenophenes.

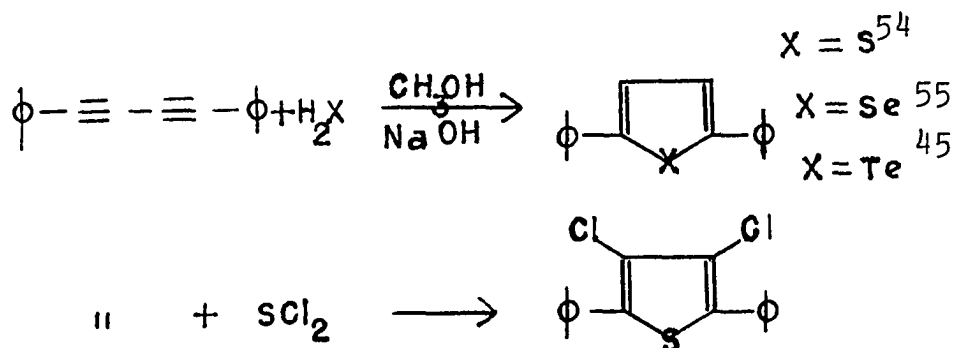

The classic method is the Hinsberg⁵⁶ thiophene synthesis.

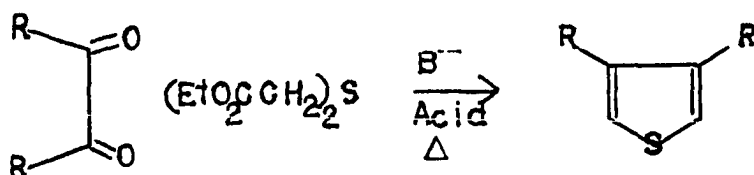

The group V and VI synthetic paths while not providing direct entry into group IV compounds, certainly demand cursory note.

Having drawn up the chemical caisson to within striking distance of the objective, assaults of the 5+2 method can be scouted. Prinzbach⁵⁷ found furan underwent easy Diels-Alder reaction with dimethylacetylene dicarboxylate to give the 7-oxanorbornadiene derivative. Irradiation at 2400 Å and above gave the oxaquadricyclane. This quadricyclane was

then thermolyzed to the unstable ($t_{1/2} = 48$ min. @ 108°C) oxepin derivative.

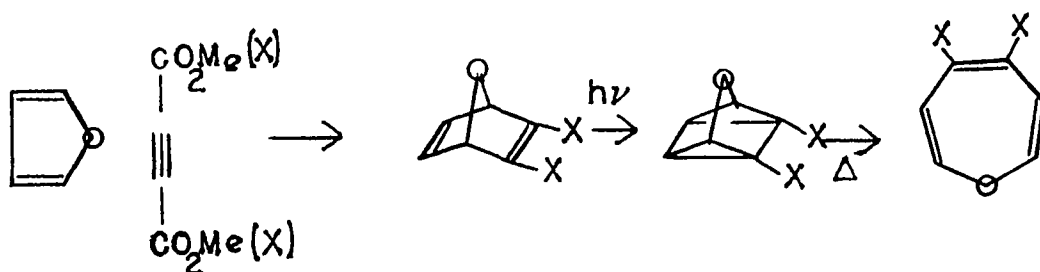

Prinzbach⁵⁸ also used the same method in generating the azepin.

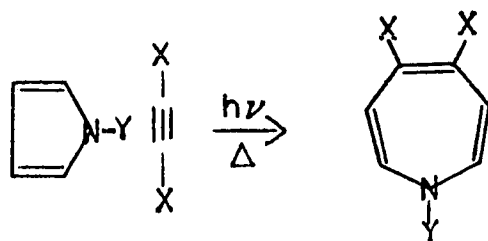

There is precedent from the literature for the availability of group IV 7-heteronorbodienes. Gilman^{59,60} has added benzyne and dimethylacetylene dicarboxylate (DMAC) to hexaphenylsilole and 1,1-dimethyl-2,3,4,5-tetraphenylsilole to give the corresponding Diels-Alder products. In view of Prinzbach's success at rearranging the 7-oxanorbodiene, it would seem possible to rearrange such group IV compounds in an analogous fashion. Indeed, Gilman⁶⁰ described the rearrangement in benzene and ethanol of the DMAC adduct

of hexaphenylsilole as giving a product with a tentative silepin ring structure. However, the phenyl substitution did not permit any conclusive analysis of that rearrangement product. Zuckerman⁶¹ and Hota and Willis⁶² have synthesized analogous germanium compounds. Zuckerman found the 1,1-dimethyl-2,3,4,5-tetraphenylgermole adduct with DMAC to be stable, undergoing germanium-carbon bond fission at 55° to 60° C.

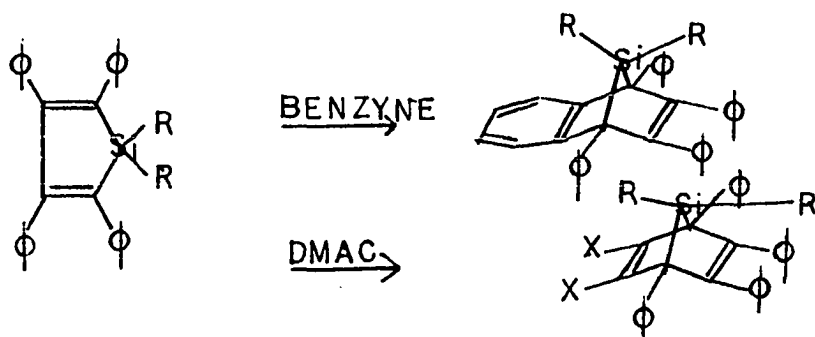

Schenck⁶³ has studied the sensitized photoadditions to thiophene and furan. Photolysis of neat mixtures of furan and maleic anhydride, dimethylmaleic anhydride, N-phenylmaleimide or 3,4-dimethyl-N-phenylmaleimide with vicor filtered radiation, a wavelength of 2400 Å and above, gave the 2+2 photoaddition products.

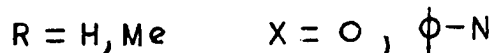
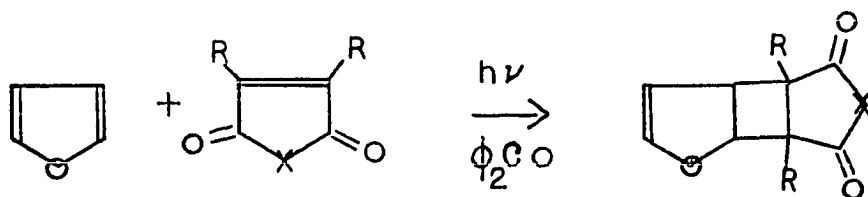

Photolysis of a neat mixture of thiophene⁶⁴ and dimethylmaleic anhydride in the same manner also yielded the 2+2 addition product. Although Schenck did not carry out any further reactions on the photolysis product, hydrolysis followed by decarboxylation and thermolysis could give the heterocycloheptatriene.

Märkl⁶⁵ actually carried out such a sequence in his synthesis of the 1-oxa-1-phenylphosphepin. Photolysis of dichloromalimide with 1-phenyl-1-phosphacyclopent-3-ene-1-oxide gave the 2+2 adduct. Hydrolysis of the syn isomer followed by hydrogenolysis of the chlorines and electrolytic decarboxylation gave the bicyclo[3.2.0]-1-phosphaheptene. It was then easily thermolyzed to 1-phenyl-1-phosphacyclohepta-3,5-diene-1-oxide. Bromination and dehydrobromination gave the desired 1-phenylphosphepin-1-oxide.

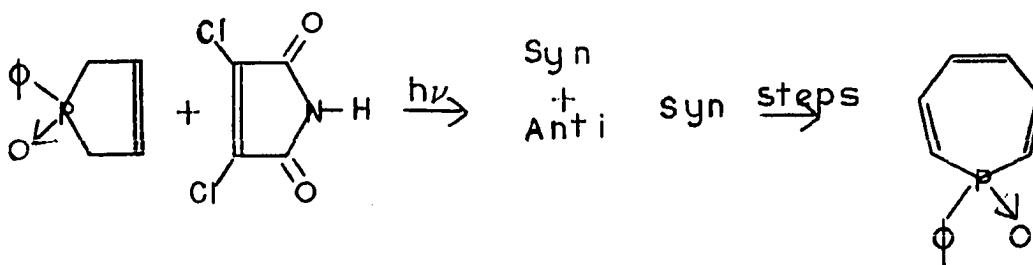

Examples of the diverse nature of the photoaddition are provided by the following reactions. Schenck⁶⁶ added dimethylmaleic anhydride to 1,3-diacetylimidazolin-2-one and found the 1:1 photoproduct. Rosenberg⁶⁷ found the unsensitized photoreaction of furan with diphenylacetylene gave 2,3-dihydropyran through a 1,2 cycloaddition intermediate.

Neckers observed sensitized photoaddition of olefins to benzo(b)thiophene in his investigations with Wynberg. He found cis or trans-1,2-dichloroethylene⁶⁸ added in a 2+2 cycloaddition fashion to benzo(b)thiophene. He also reported a 1,2 cycloaddition of 1,2-dichloroethylene to thiophene but

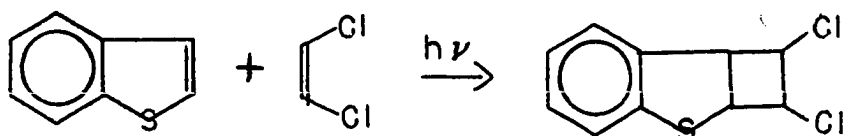

did not elaborate. Neckers⁶⁹ observed a slightly different result when the photophile was dimethylacetylene dicarboxylate. Here the substitution indicated rearrangement of the initial 2+2 adduct.

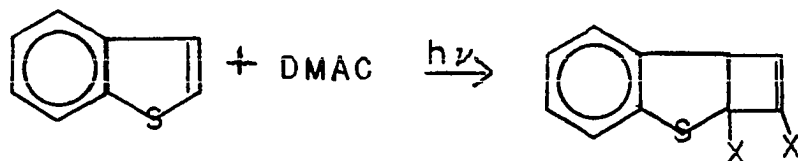

Wynberg⁷⁰ studied the mode of 2-phenylthiophene rearrangement by quenching with olefins. He found direct photolysis of 2-phenylthiophene at 2400 Å in the presence of piperylene did not give the normal product, 3-phenylthiophene; instead, he isolated a 1:1 adduct of piperylene and 2-phenylthiophene. No structure was given.

The two reaction schemes posed for group IV heterocycloheptatriene synthesis from the 5+2 method are formation of a bicyclo[3.2.0]-1-heteroheptadiene and formation of the 7-heteronorbornadiene. These two key intermediates should then yield the open ring by rearrangement.

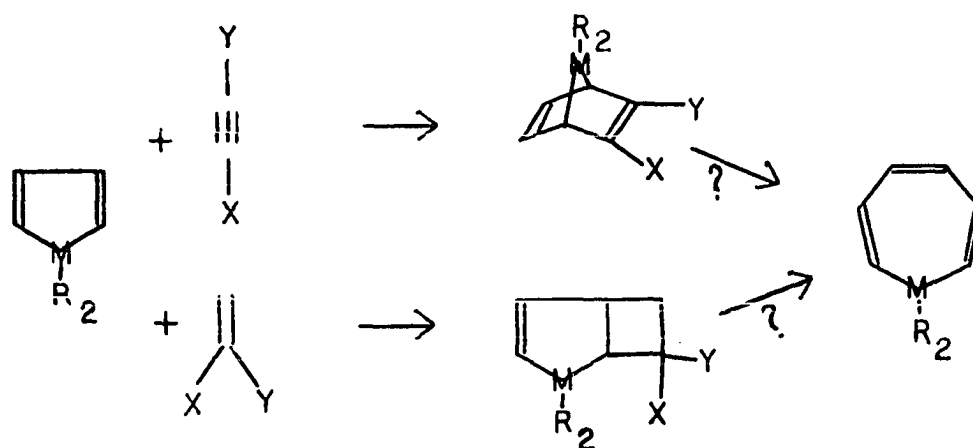

6 + 1 method

The most manifest method is carbene addition to silacyclohexene. Zuckerman⁷¹ reported in 1971 an unsuccessful attempt at synthesis of a silepin by this approach. Addition of dichlorocarbene to 1,1-dimethyl-1-silacyclohex-3-ene⁷²

generated 1,1-dimethyl-6,6-dichloro-1-silabicyclo[4.1.0]-heptane. Removal of hydrogen chloride with the wonder base DBU did not give the silepin. Instead the rearranged norcaradiene was found.

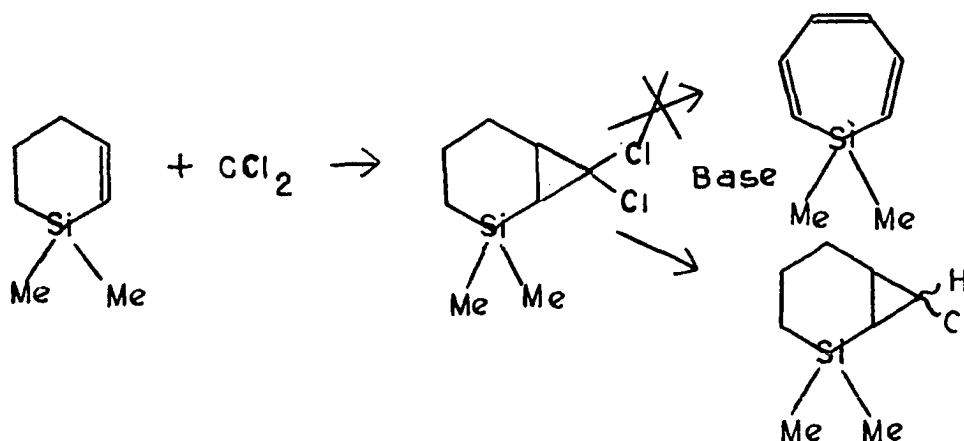

Perhaps a different substitution pattern will permit facile hydrogen chloride elimination. However, it appears the best potential precursor did not work.

Carbenes have been added to oxygen and sulfur compounds in like attempts to synthesize oxepin and thiepin ring systems. Dichlorocarbene reacted with 2,3-dihydropyran⁷³ to give the [4.1.0] adduct. Pyrolysis of this adduct produced the dihydrooxepin in about 30% yield. Dichlorocarbene addition to 2,3-benzothiran⁷⁴ also gave the three membered ring intermediate. However, pyrolysis of this compound in boiling quinoline did not allow isolation of the corresponding dihydrothiepin. Instead, β -chloronaphthalene

is produced from sulfur extrusion.

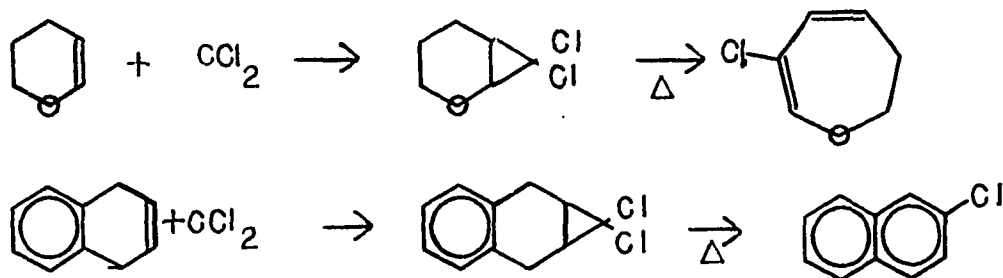

Ring closure using a six-membered chain and heteroatom reagent might seem a questionable method. The tendency to form polymeric chains of the type $\text{R}(\text{CH}=\text{CH})_3\text{-M}(\text{CH}=\text{CH})\text{R}$ could be great. However, ring closure has worked very well for the synthesis of five membered rings such as silole, phosphole, thiophene and pyrrole. By analogy synthesis in the seven-membered series might also work.

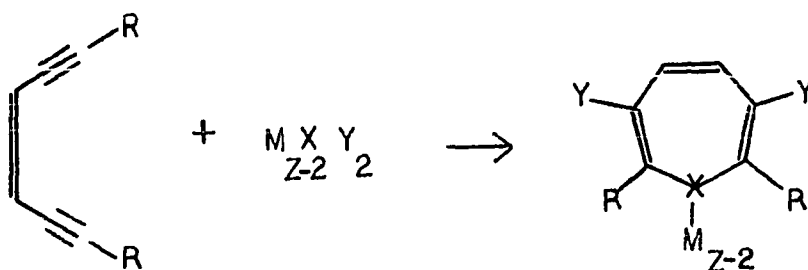

According to the literature, the best plan appears to be the five plus two method. It has both a number of documented methods and a cornucopia of heterocyclopentadienes.

The next section deals with some photochemistry of various heterocyclopentadienes.

PHOTOCHEMISTRY OF HETEROCYCLOPENTADIENES
THE RELATION OF STRUCTURE TO REACTIVITY

Photodimerization and aromaticity

The investigations outlined in the preceding section by Schenck, Neckers, Wynberg and others lends credibility to the photoaddition of olefins to heterocyclopentadienes. However, as occurs with all experimental studies, some molecules just don't know how they are supposed to react. For instance, Wynberg found photorearrangement of the isolated substrate took place in the thiophene series^{75,76}. Direct photolysis of various 2-substituted thiophenes at 2540 Å gave the corresponding 3-substituted thiophenes in 30 to 70 percent

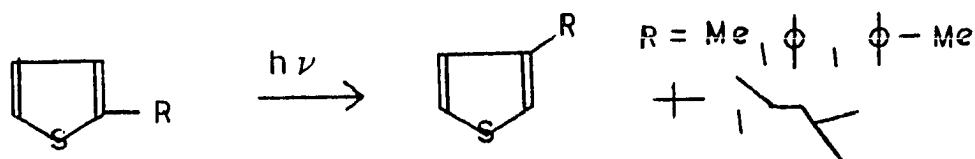

Photolysis of 2,5-di-*t*-butylthiophene and thienothiophene also gave similar results⁷⁵.

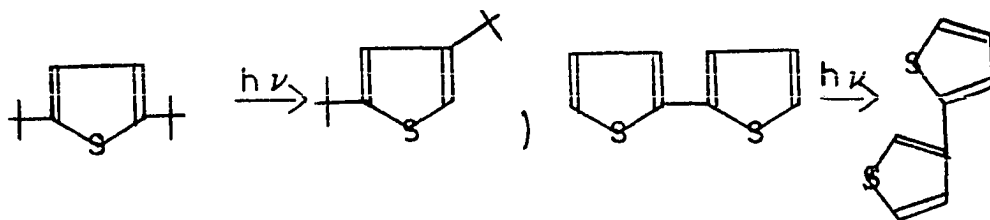

The mechanism of the reaction has been discussed in terms of deuterium labeling^{77,78}, carbon-14 labeling⁷⁹ and fluorescence quenching studies⁸⁰. The authors postulate two intermediates in the reaction pathway, but favor the valence expanded intermediate on basis of the fluorescence quenching results.

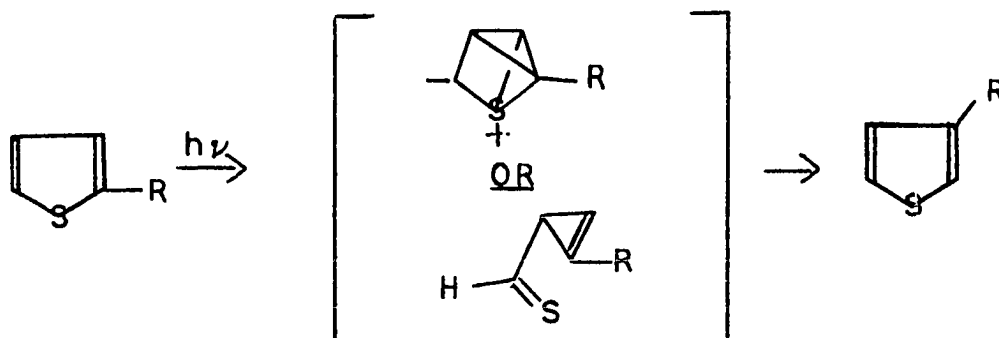

Ulman⁸¹ has studied the rearrangement of isoxazoles and has been able to isolate an azirene intermediate.

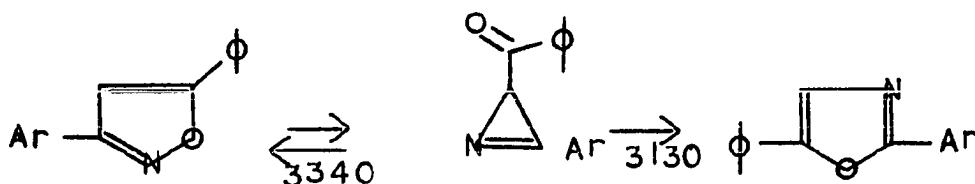

VanTamelen⁸² studied the photolysis of 2-5-di-t-butylfuran and was able to isolate the ketocyclopropene.

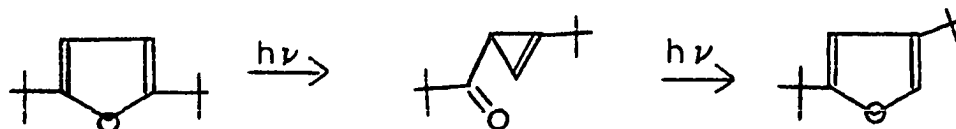

He used the same type of mechanistic intermediate, in contrast to Wynberg's conclusions, to interpret the scrambling results of Wynberg's 2-carbon-14-2-phenylthiophene photolysis.

Although Wynberg⁸³ found no photorearrangement of 2,5-diphenylthiophene, the absence of the expected 3,4-diphenylthiophene may be due to a no-reaction reaction. Both mechanisms predict collapse of the intermediate to the most thermodynamically stable product. The mode of reaction could be largely due to a delicate balance of electronic and thermodynamic factors, making 3,4-diphenylthiophene higher in energy than 2,5-diphenylthiophene.

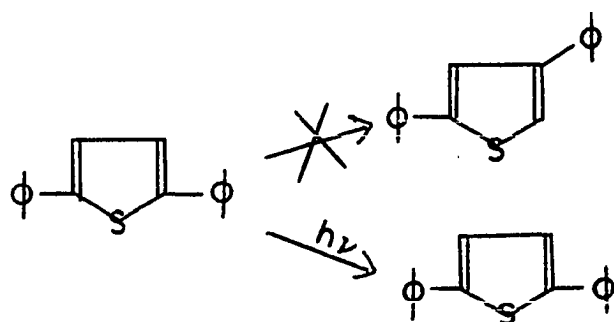

It is quite plain from the above discussion that the photochemistry of the heterocyclopentadienes themselves must be investigated before any attempt can be made at producing a 2+2 cycloaddition product.

The series of photoreactions studied are shown on page 38. Photolysis of ether solutions of 1,1-dimethyl-2,5-diphenylsilole⁸⁴ 1 at radiation wavelengths of 3000 Å and above resulted in the formation of a colorless crystalline material 2 (mp 197° - 198° C) in about four to six hours. The elemental analysis dictated an empirical formula of C₁₈H₁₈Si, that of the silole 1. However, the mass spectrum indicated the molecular formula to be twice that of the silole 1. The 70 eV. spectrum showed cleavage of the dimer 2 (m/e 524) back to the monomer 1 (m/e 262) and subsequent loss of the silicon methyls (m/e 247 and 232). The NMR, shown in Figure 2b, provided convincing evidence for the 2+2 dimerization. It has an aromatic and olefinic multiplet centered at δ7.09 consisting of 22 protons. There is a doublet at δ4.26 for the two allyl signals. The coupling constant J_{ax} is 3.6 Hz. The reported coupling constant for an analogous compound 2,7-dimethyl-5,5-diphenyl-1,6-dioxabicyclo[3.2.0]hept-2-ene⁸⁵ is 3.1 Hz which shows the reasonableness of the dimer structure. The methyl signals come at δ0.31 and δ-0.31 as singlets which integrated to six protons each. The head-to-tail nature of the photodimer was determined by a single crystal X-ray study. The stereochemistry about the cyclobutane ring may be assumed because of the concerted nature of the reaction. But, the crystal structure confirmed this assumption⁸⁶. The computer drawn structure is shown in Figure 3.

Photodimerizations of heterocyclopentadienes which were studied. The light wavelengths were usually 3000 Å. The products were colorless crystalline solids.

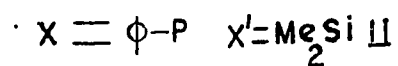
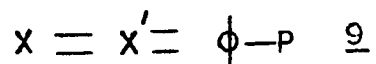
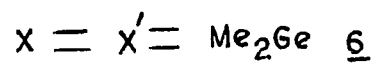
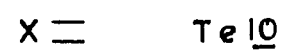
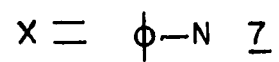
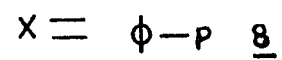
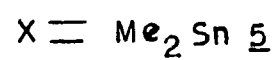
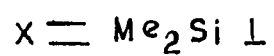
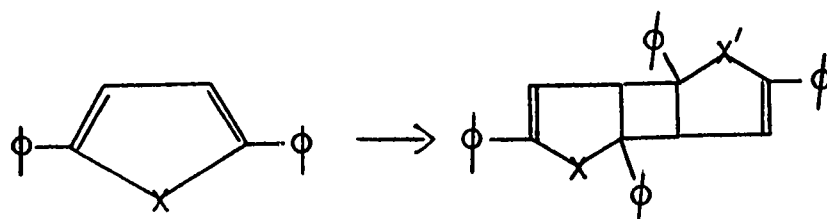

Figure 2a. 60 MHz NMR spectrum of a mixture of silole 1 and dimer 2

Figure 2b. 60 MHz NMR spectrum of pure dimer 2

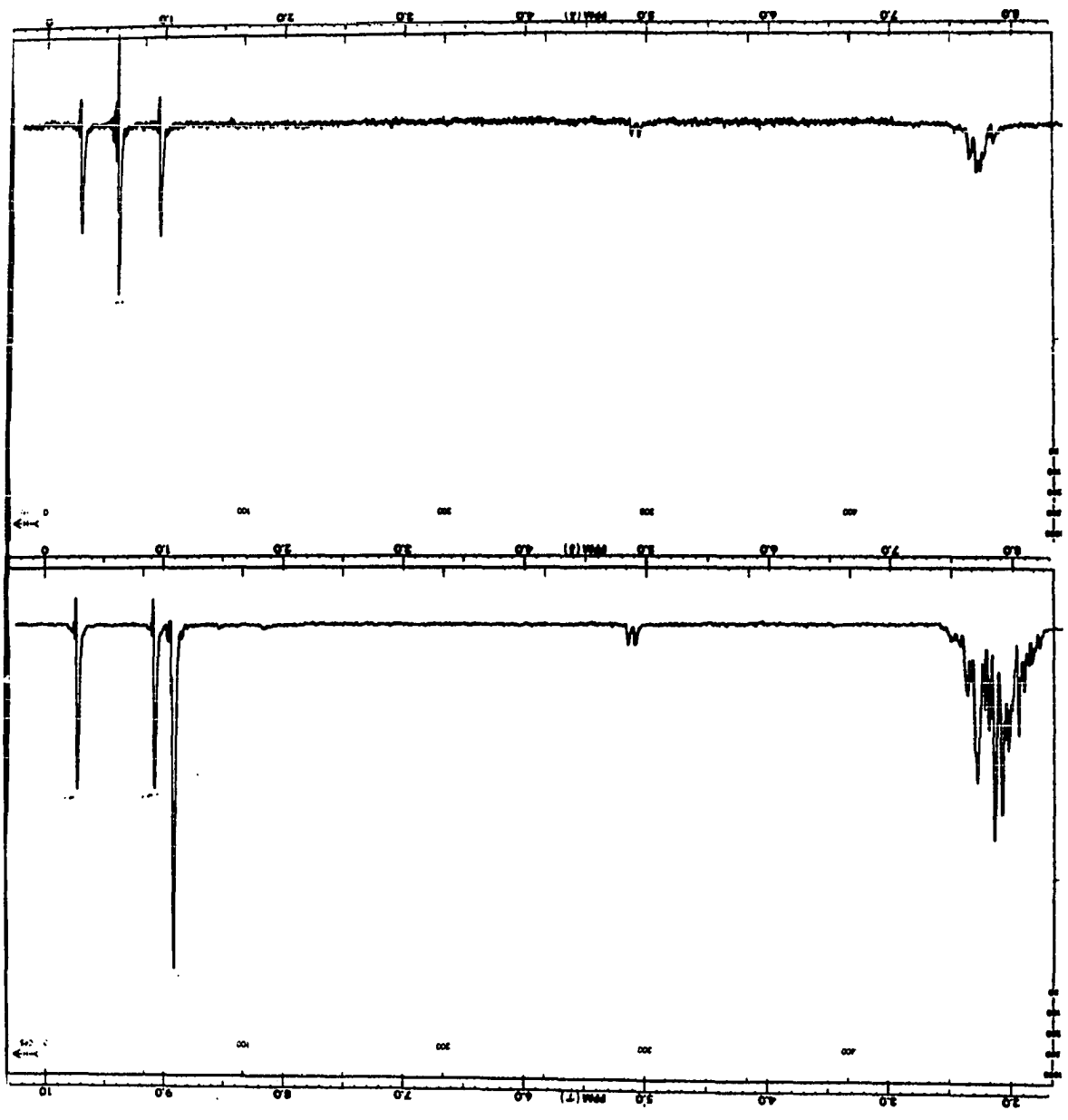
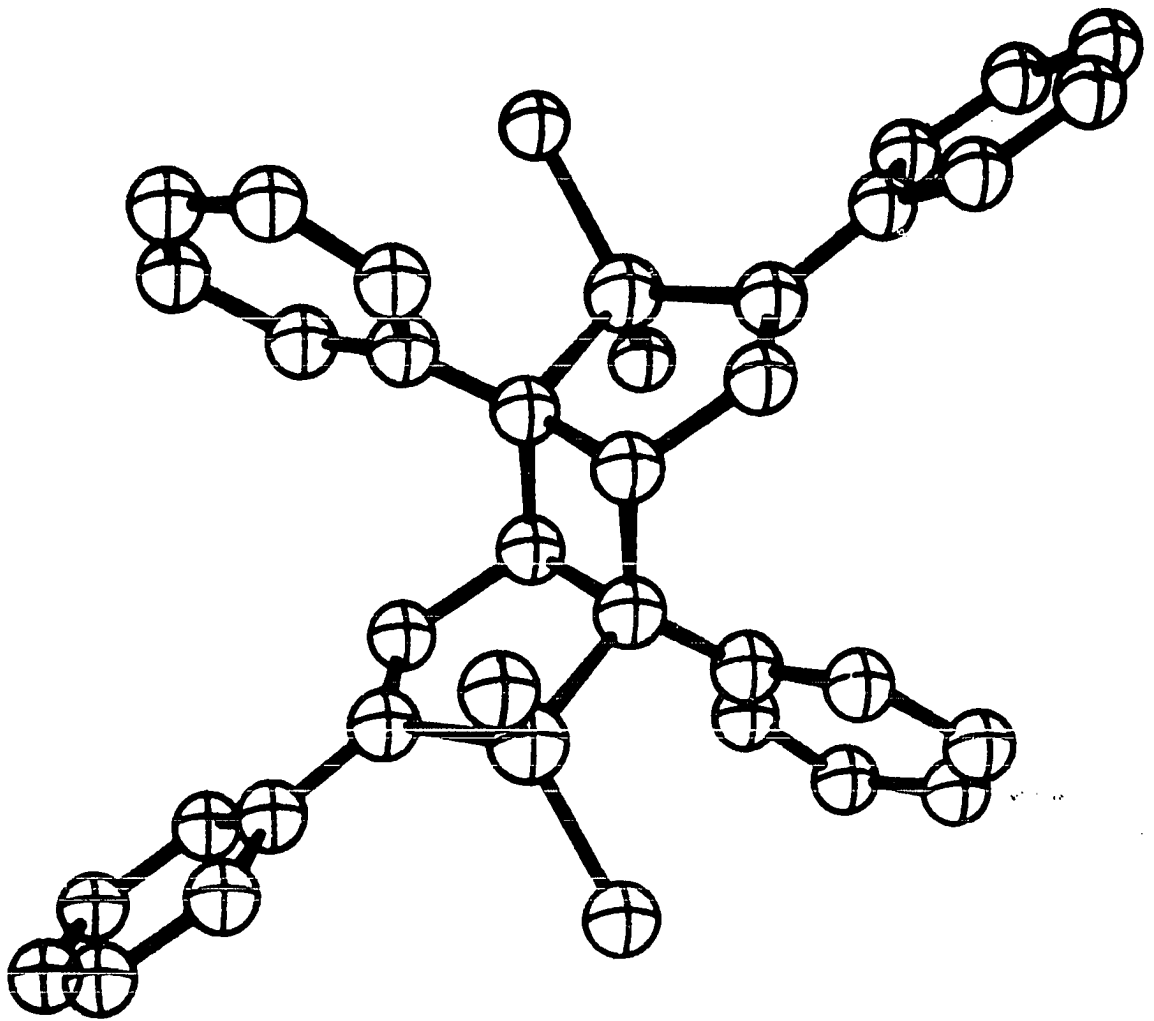

Figure 3. Crystal structure of silole dimer 2



Although the method of Atwell and Gilman for the preparation of 1 is a good procedure, dehydrogenation using 2,3-dichloro-5,6-dicyanoquinone 3 gave better over-all yields. Routinely a 1.2 to 1 molar ratio of 3 to 1,1-dimethyl-2,5-dimethyl-2,5-diphenyl-1-silacyclopentane⁸⁴ was refluxed in benzene overnight to give 80 to 90 percent yields of 1.

1,1-dimethyl-2,5-diphenylgermole 4 was prepared by a method similar to that reported by Atwell and Gilman⁸⁴ for the preparation of 1,1-dimethyl-2,5-diphenylstannole 5. Addition of an equimolar solution of 1,4-diphenyl-1,4-dilithiobutadiene in ether to dimethyldichlorosilane gave the desired germole 4 in 60 percent yield. The NMR spectrum was similar to that of the silole 1. It had an aromatic and olefinic multiplet at $\delta 7.40$ and $\delta 7.15$ and integrated for twelve protons. The methyl signals were a singlet at $\delta 0.68$ showing six protons. The mass spectrum showed the correct isotope abundance with peaks at m/e 308, 37% (Ge^{74}); $m/3$ 306, 27% (Ge^{72}) and m/e 304, 20% (Ge^{70}) for the parent ion. The ultraviolet spectrum had a broad λ_{max} at 3640 \AA and is similar to that of the silole 1 (λ_{max} at 3700 \AA) but is shifted to slightly shorter wavelengths.

That the dramatic dimerization as opposed to rearrangement is general and not a novel function of the silicon atom is demonstrated by the photolysis of hundredth molar solutions of germole 4 in ether. Irradiation at wavelengths

greater than 3000 Å of such solutions afforded a white crystalline material 6 (mp 215 - 217° C) whose NMR, shown in Figure 4b, is slightly shifted downfield from that of the silole dimer 2. The shape remains the same with an aromatic and olefinic multiplet located at $\delta 7.15$, center, with 22 protons. There is a doublet for the two allyl signals at $\delta 4.35$. The coupling constant J_{ax} is 4 Hz, in accord with that found for the silole dimer 2. The methyl signals are a pair of singlets at $\delta 0.44$ and $\delta -0.23$ and integrated for six protons each. The upfield shift of one of the two methyl signals is presumably due to the shielding effect of the phenyl group attached to the fused cyclobutane ring. The mass spectrum indicated the presence of a series of isotopes in the m/e 608 to 616 region, correct for the dimer 6. However, the accuracy of the spectrometer in this region did not permit accurate measurement.

Photolysis of the heavier group IV heterocycle stannole⁸⁷ 5 did not give a 2+2 cycloaddition product. Instead, photolysis of ether solutions of 5 at wavelengths greater than 3000 Å gave a white powdery solid with a molecular weight in the region ca. 362. Although comment on the structure of the compound is inviting the "cat to strike", it is at least safe to say the white material is composed of tin and not much else due to the isotope ratios in that region. Tin-carbon bond cleavage in such a photolytic

Figure 4a. 60 MHz NMR spectrum of phosphole dimer 9

Figure 4b. 60 MHz NMR spectrum of germole dimer 6

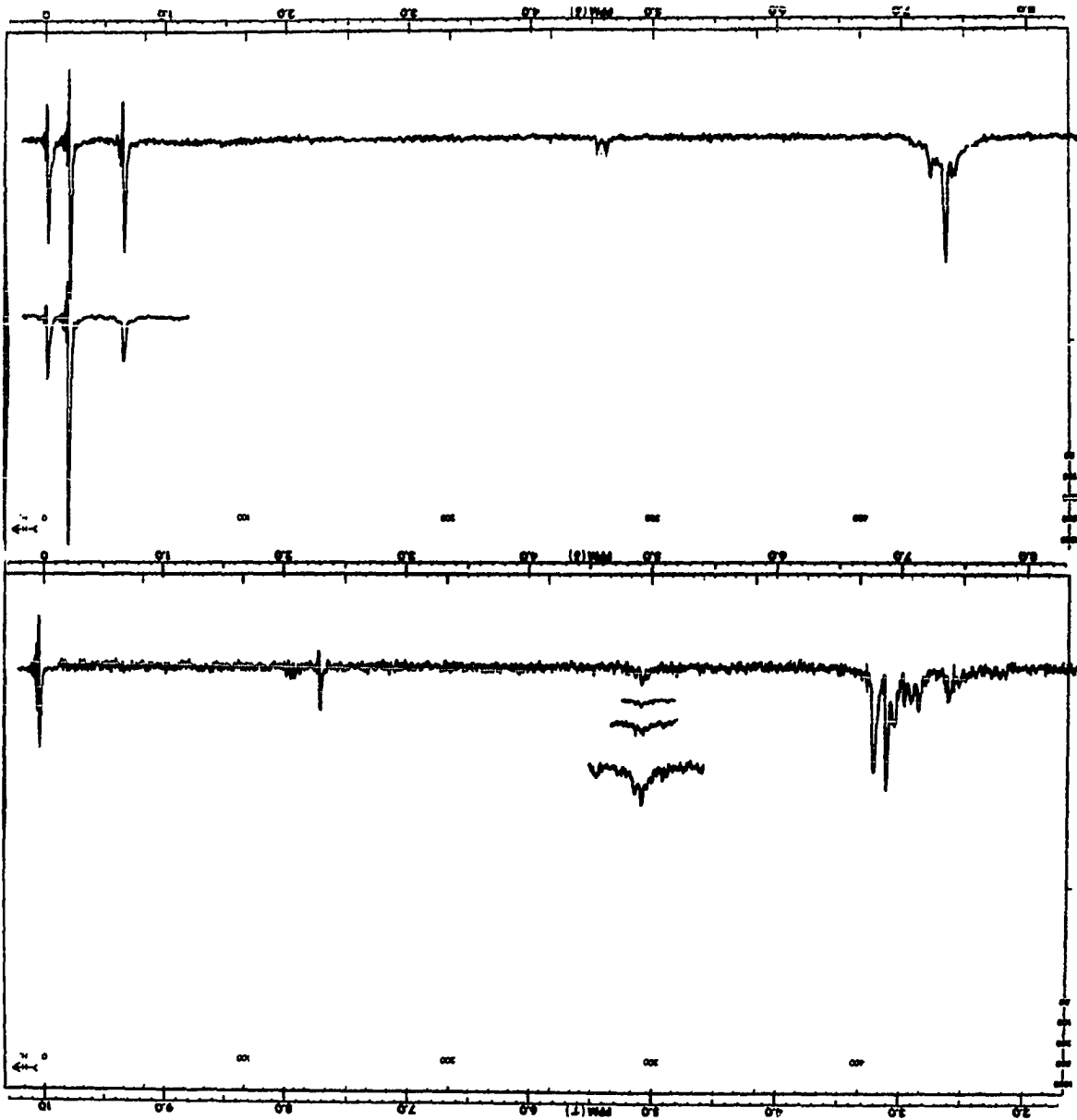

reaction has been documented^{88,89}. Sato⁹⁰ found the photolysis of 1,1-diphenyl-4,5-dihydro-1-stannacyclohepta-2,6-diene gave a 56 percent yield of a polymer ($\Phi\Phi\text{SnCHCHCH}_2\text{CH}_2\text{CHCH}_n$) in addition to a ring opened dimer.

What may be said in distinction between the photo-rearrangements of alkyl substituted furans and thiophenes and the group IV heterocyclopentadienes found here? Those heterocyclopentadienes which fit the Hückel rule gave rearrangement but did not undergo destruction of the six pi electron system. Therefore, a hypothesis may be formed saying photodimerization is a function of aromaticity. Those molecules having no aromaticity to be lost will photodimerize. Indeed, such a rationale is operative in the photoreaction of benzo(b)thiophene⁹¹, aromatic, as compared to benzo(b)thiophene-1,1-dioxide^{92,93}, not aromatic. Photolysis of the dioxide gave the 2+2 cycloaddition product of unspecified stereochemistry around the cyclobutane ring. However, the benzo(b)thiophene gave a coupling product and a product of sulfur elimination.

The photolytic reactions of group V and VI heterocyclopentadienes casts a favorable light on the aromaticity prediction. Irradiation of solutions of 1,2,5-triphenylpyrrole 7⁹⁴ through a Pyrex filter, admitting wavelengths greater than 3000 Å, gave no rearrangement or dimerization.

Irradiation of solutions of 7 through quartz, wavelengths greater than 2200 Å, gave only decomposition products.

1,2,5-triphenylphosphole 8⁴⁶, however, was converted to the dimer 9 when photolysed in 50 percent THF/ether solutions at wavelengths above 3000 Å. The dimer was identified by its mass spectrum with an M+ of ca. 624. However, this mass is about at the limit of the spectrometer and could not be determined accurately. 9 Cleaved across the cyclobutane ring to form the monomer m/e 312 when the 70 eV. spectrum was taken. 9 Had a correct elemental analysis and an NMR consistent with the previous dimers found. The NMR, shown in Figure 4a, exhibits a multiplet at δ7.03, center for the 32 aromatic and olefinic protons. The small multiplet at δ4.88 is assignable to the two allyl protons. RF irradiation at phosphorus (24.2897 MHz) caused collapse of this multiplet to a doublet. The chemical shift is consistent with that found for the allyl signals of 2 and 6.

2,5-Diphenyltellurophene⁴⁵ 10 behaved like the analogous thiophene derivative upon irradiation. Photolysis through Pyrex of THF solutions caused slight decomposition of 10 as evidenced by a black metallic precipitate. But, the starting substrate 10 was isolated in greater than 90 percent yield after reaction times of eighteen hours. The aromaticity of 10 might be doubted due to the ineffective overlap of the Te5p-C2p orbitals. However, recently the

classic reaction of aromatic compounds, i.e., electrophilic aromatic substitution, has been run on the parent system with success⁴⁴.

The aromaticity hypothesis has proved true for at least two of the compounds which are aromatic, 7 and 10, but what may be said of 8? Claims⁹⁵ have been made about phosphole derivative aromaticity and it would seem *á priori* that conjugation of the lone pair of electrons on phosphorus with the butadiene fragment has a stabilizing influence on the molecule. In contradiction, Mislow⁹⁶ has demonstrated the phosphorus to be sp^3 hybridized in phospholes by NMR studies. He found the stabilization gained by conjugation of the lone pair of electrons with the butadiene fragment in the planar form of the ring lowered the energy of activation for phosphorus inversion. But, the planar form is only a transition between the two more stable non-planar or puckered forms. From Mislow's arguments 8 should not be planar. Rehybridization of the phosphorus from sp^3 to sp^2 results in added strain on the C-P-C bond angle. This increase in energy is not compensated for by the conjugation of the lone pair of electrons. Therefore, the lowest energy form is non-planar.

The non-planarity of 8 could also be due to the steric interaction of phenyl-phenyl collision. Such interaction might raise the energy requirement of the planar form in

TABLE 1. UV Spectra of Some Heterocyclopentadienes

Compound	λ_{\max} Å	$\epsilon \times 10^{-4}$	Ref. No.
cyclopentadiene	2000 2380		Jaffé & Orchin ⁹⁷
furan	1910 2050		Jaffé & Orchin ⁹⁷
pyrrole	1830 2110		Jaffé & Orchin ⁹⁷
thiophene	2040 2210		Jaffé & Orchin ⁹⁷
2,5-diphenylthiophene	2300 3230	1.15 2.58	King, Bauer, Lutz ⁹⁸
2,5-diphenylfuran	2260 3240	1.62 2.92	King, Bauer, Lutz ⁹⁸
1,2,5-triphenylpyrrole	3010	1.95	King, Bauer, Lutz ⁹⁸
1,2,5-triphenylphosphole	2220 3690	2.40 1.78	Cookson ⁹⁹
1,1-dimethyl-2,5-diphenylsilole	2300 3700	1.3 2.0	Atwell, Gilman ¹⁰⁰
1,1-dimethyl-2,5-diphenylgermole	2300 3640	1.56 1.92	This Thesis
1,1-dimethyl-2,5-diphenylstannole	2300 3660	1.02 2.26	Atwell, Gilman ¹⁰⁰
2,5-diphenyltellurophene	2200 3120	1.05 2.40	This Thesis and 101
1,4-diphenylcyclopentadiene	2350 3500	1.41 2.63	Bladon ¹⁰²

addition to the bond angle strain. The additional energy could be enough to make the planar form higher in energy than the non-planar form. To this end the geometry of the model compound 7 whose photochemistry follows the aromaticity hypothesis, was examined. The crystal structure of it and of 8 are shown in Figures 5 and 6. The pictures point out that steric strain of the phenyls is not a problem. The pyrrole 7 is still planar while 8 is not. The conclusion is since 8 has no stability resulting from conjugation of the lone pair of electrons, then it should undergo photodimerization.

The ultraviolet spectra of the several heterocyclopentadienes studied are given in Table 1. The change in UV absorption of the aromatic compounds such as thiophene or pyrrole can be correlated to the differences in molecular orbitals. All those compounds having an aromatic nature have absorptions ca. 300 mu. to 320 mu. The compounds not having an aromatic nature either because of lack of electrons or delocalization have absorptions ca. 350 mu. to 370 mu. The ratio of the long wavelength transitions is 1.23.

The model compounds furan and cyclopentadiene enable theoretical correlation to be made. Orloff and Fitts¹⁰³ have calculated the molecular orbital energies of furan. The energy difference for the lowest energy transition is 6.4 eV. or 147.6 Kcal/mole. Allinger¹⁰⁴ has calculated the low energy spectral transitions for cyclopentadiene. The

Figure 5. Crystal structure of pyrrole 7

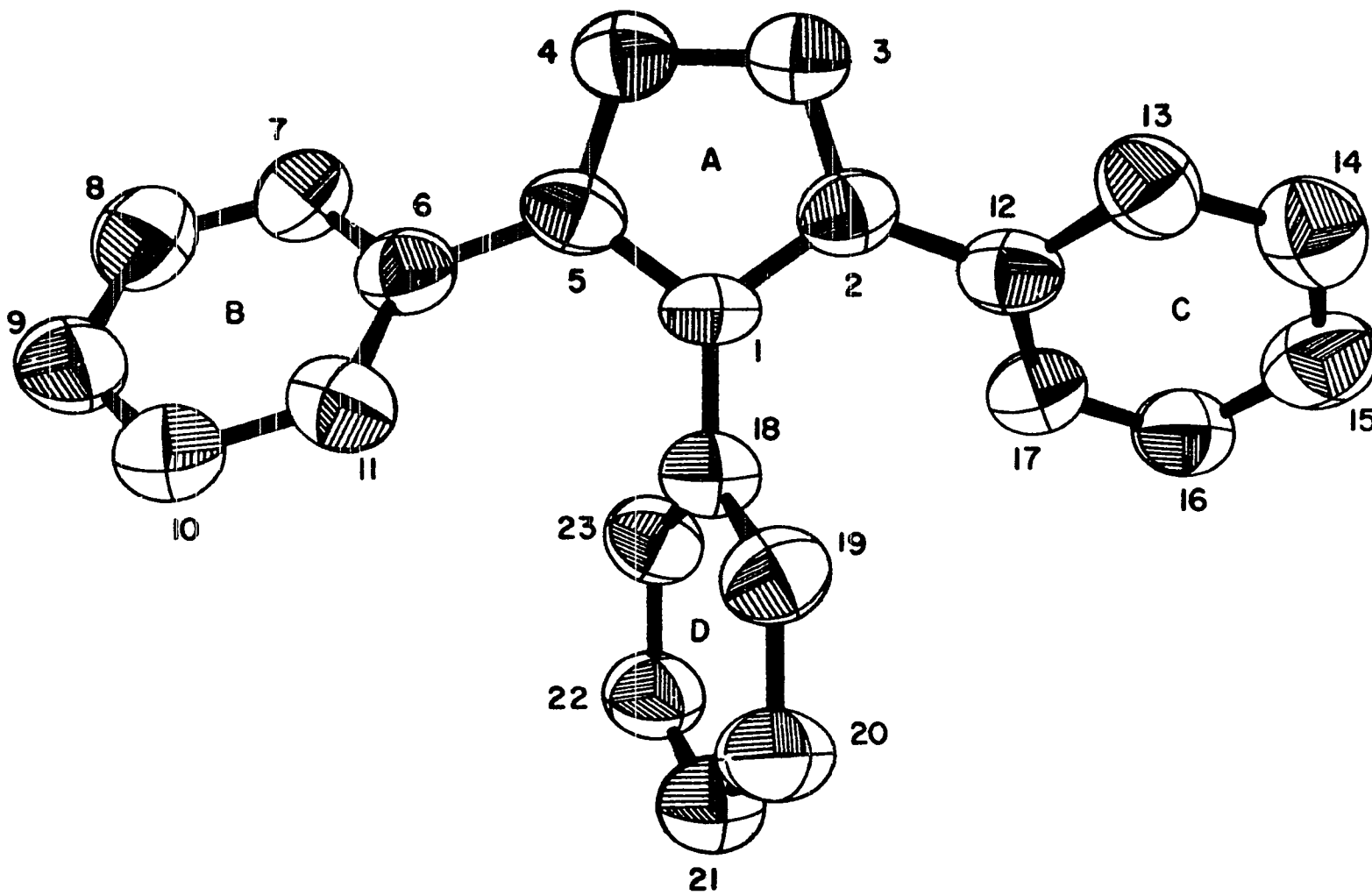
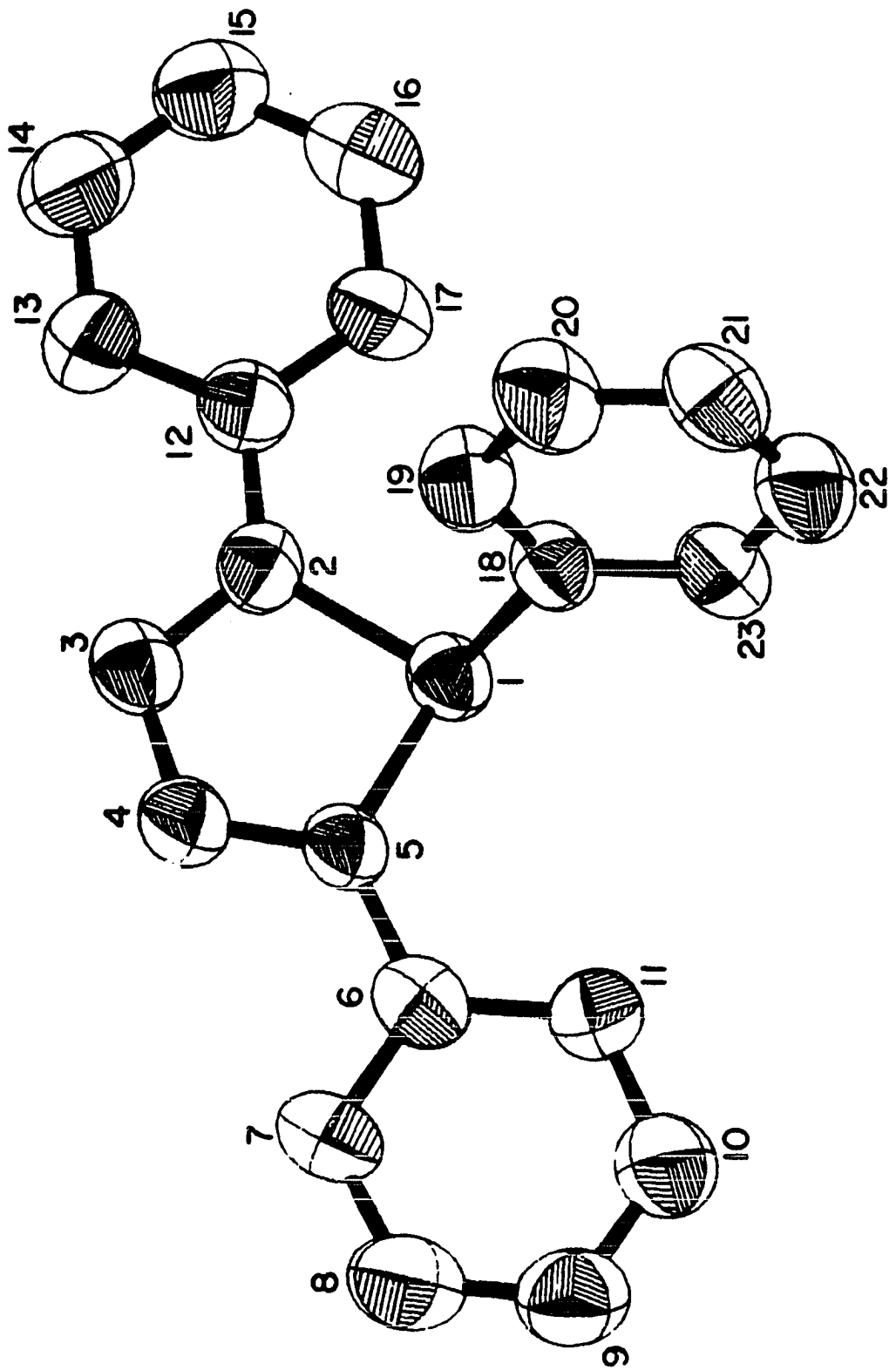

Figure 6. Crystal structure of phosphole 8



N to V_1 transition to the first excited state has an energy of 4.96 eV. or 119 Kcal/mole. Calculations on both molecules, the furan and cyclopentadiene, CPD, were done using the Pariser-Parr¹⁰⁵ method of LCAO-SCF-MO's. The excited state energies were found by allowing certain excited configurations to interact. Correlation of the excited states with experiment is shown. The calculated values give a ratio of 1.27 between furan and CPD low energy transitions.

(Aromatics)		Transition	Calc eV.	obs eV.		(CPD)
A'	_____ 7.68	$^1(A \rightarrow B^1)$	6.4	6.5	} furan	_____ U ₂
B'	_____ 7.30	$^1(A \rightarrow A^1)$	6.9	7.4		_____ U ₁
A	_____ -4.88	$N \rightarrow V_1$	4.96	5.29	} CPD	_____ G ₂
B	_____ -5.90	$N \rightarrow V_2$	5.71	6.16		_____ G ₁
C	_____ -10.19	$N = ^2G_1, ^2G_2$ $V_1 = ^2G_1, ^1G_2, ^1U_1$				_____ G ₁

It is expected that the effect of the phenyls would be the same in both cases. This effect would change the absolute energies (dependent on λ) but not their ratios. These calculations agree closely with the transition ratio found from experiment, 1.23 vs. 1.27.

The nonplanarity of the phosphole will increase the energy of the bonding molecular orbitals in the aromatic scheme. Orbital A will increase in energy toward the non-bonding line. At the same time one of the antibonding

orbitals will decrease in energy. The electronic transition from the bonding orbital A to the antibonding orbitals then becomes very close in energy to the transition for the non-aromatics. This statement does not say the phosphole M.O.'s are like those of the silole or cyclopentadiene. Although the lone pair is in an sp^3 hybrid orbital, there is still partial overlap of that orbital with the butadiene fragment orbitals. Proper calculations, most likely of the extended Hückel type, would have to be done in order to gain a good picture of the bonding scheme.

In an effort to control the photodimerization, the solid state photolysis of silole 1 was investigated. Photolysis through Pyrex of a finely powdered sample of 1 under a nitrogen atmosphere provided ample yields of the same 2+2 dimer as the solution study. The crystal control¹⁰⁶ of such solid state dimerizations has been investigated by G. M. J. Schmidt¹⁰⁷. He found a distance of more than 3 Å between the reacting centers will not permit photodimerization. In order to elucidate the silole crystal dimerization photoprocess, the crystal geometry, shown in Figure 7, of the monomer was determined. Distances of greater than 3 Å were found between neighbors whose geometry is correct for head to tail dimerization. Thus from the crystal structure gross molecular movement must take place; or

Figure 7. Crystal structure of silole 1 monomer

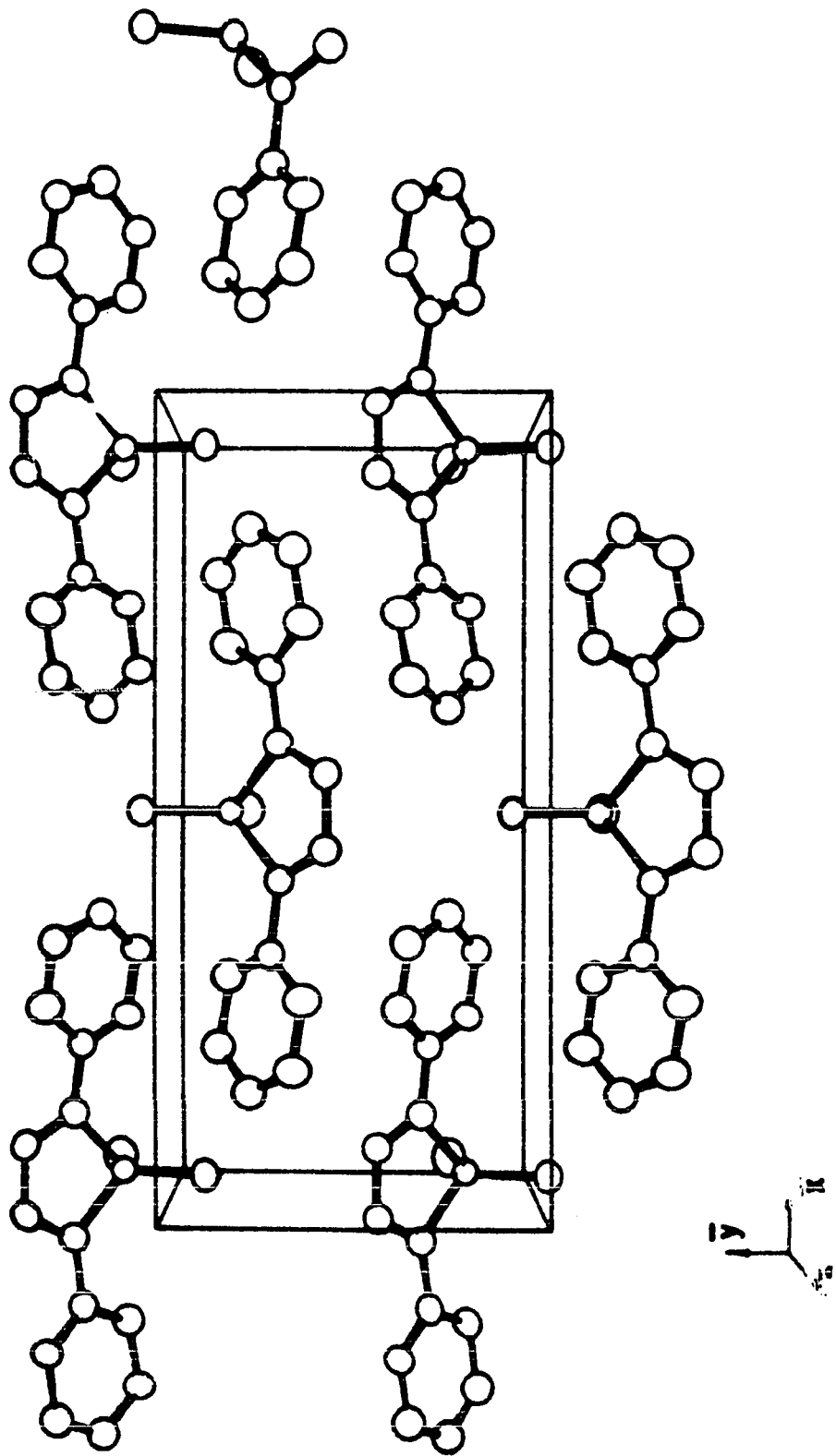

dimerization took place along fault lines and cracks (in the crystal) developing inward as the reaction proceeded.

Cycloaddition to silole 1

Since the photodimerization of silole 1 was such a facile process, the feasibility of olefin cycloaddition to 1 was put into question. Unactivated olefins were found not to capture the excited silole 1. Instead, the excited 1 was captured by another silole 1 to give the dimer. The kinetics of the process have been investigated by Weiss¹⁰⁸. He found a rate for dimerization faster than diffusion controlled. Since the rate was found by the quantum yield of dimerization, then the molecule of 1 which reacted with the singlet, excited 1, must have been in prior association with it. Otherwise, the rate should have been comparable to diffusion control. The mechanism for this process is shown on page 61. Such a process explains the absence of any cycloaddition when 1 was irradiated in the presence of diphenylacetylene, phenylacetylene, dichlorovinylene carbonate, and bromomaleic anhydride, shown on page 62.

The first example of a cycloaddition to 1 resulted from the co-dimerization with 8. Photolysis of one to one molar solutions of phosphole 8 and silole 1 provided, in addition to the dimer 2, a second compound 11 (mp. 247 - 249° C) in ca. 20 percent yield. The mass spectrum was correct for

The mechanism of
Dimer 1 formation postulated.

S = Silole 1

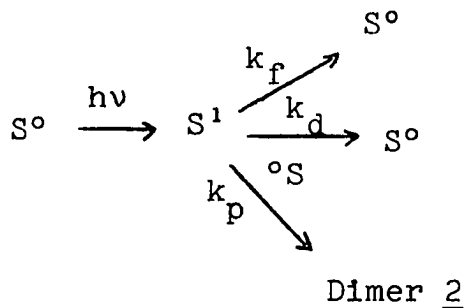

$$\phi_{\text{dimer}} = \frac{\text{Number of excited molecules going to } \underline{2}}{\text{Total quanta absorbed}}$$

τ_s = lifetime of singlet

ϕ_f = quantum yield of fluorescence

k_f = rate of fluorescence

$$\phi_d = \frac{k_p[S]}{k_f + k_d + k_p[S]}$$

$$\tau_s = 1/k_f + k_d + k_p[S]$$

k_d = rate of nonradiative decay

$$\phi_f = k_f/k_f + k_d + k_p[S]$$

k_p = rate of product formation

$$1/\phi_d = 1 + \frac{k_f + k_d}{k_p} 1/[S] \quad \text{a plot of } 1/\phi_d \text{ vs. } 1/S \text{ will give}$$

$$\frac{k_f + k_d}{k_p}$$

k_a = rate of adduct 13 formation

$$\frac{\phi_f}{\tau_s} = k_f \quad \text{assume } k_f + k_d \cong k_f$$

Weiss found k_p from the quantum yield to be at least $10^{12} \text{ sec}^{-1}\text{M}^{-1}$.

Some attempted cycloaddition reactions that were tried.

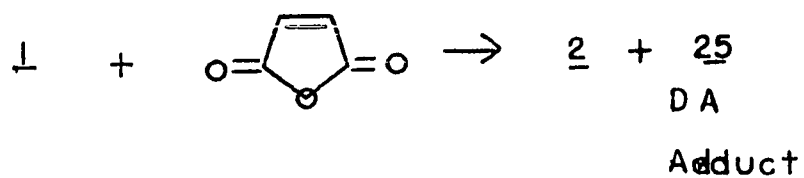
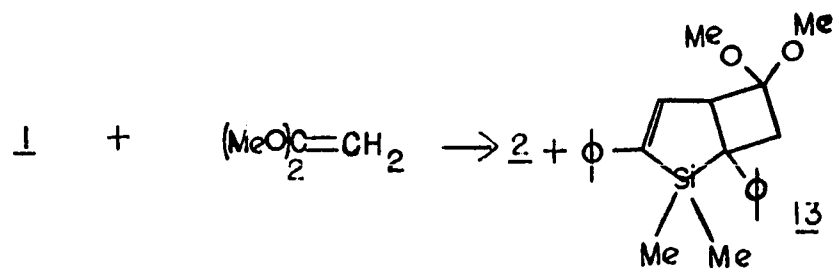
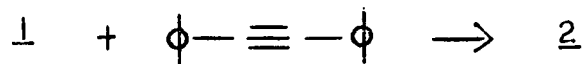
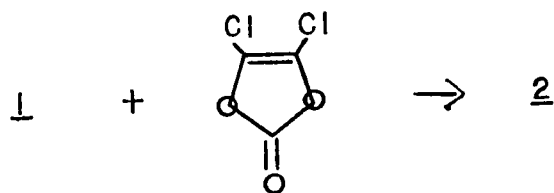
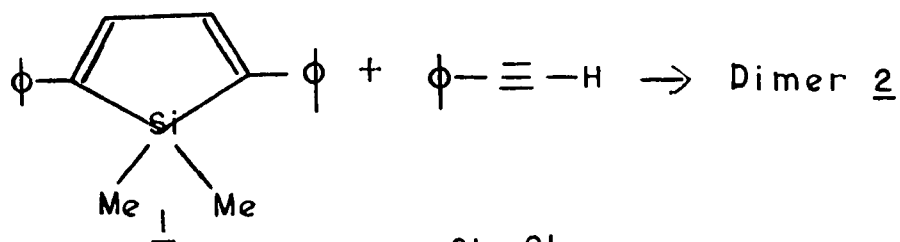
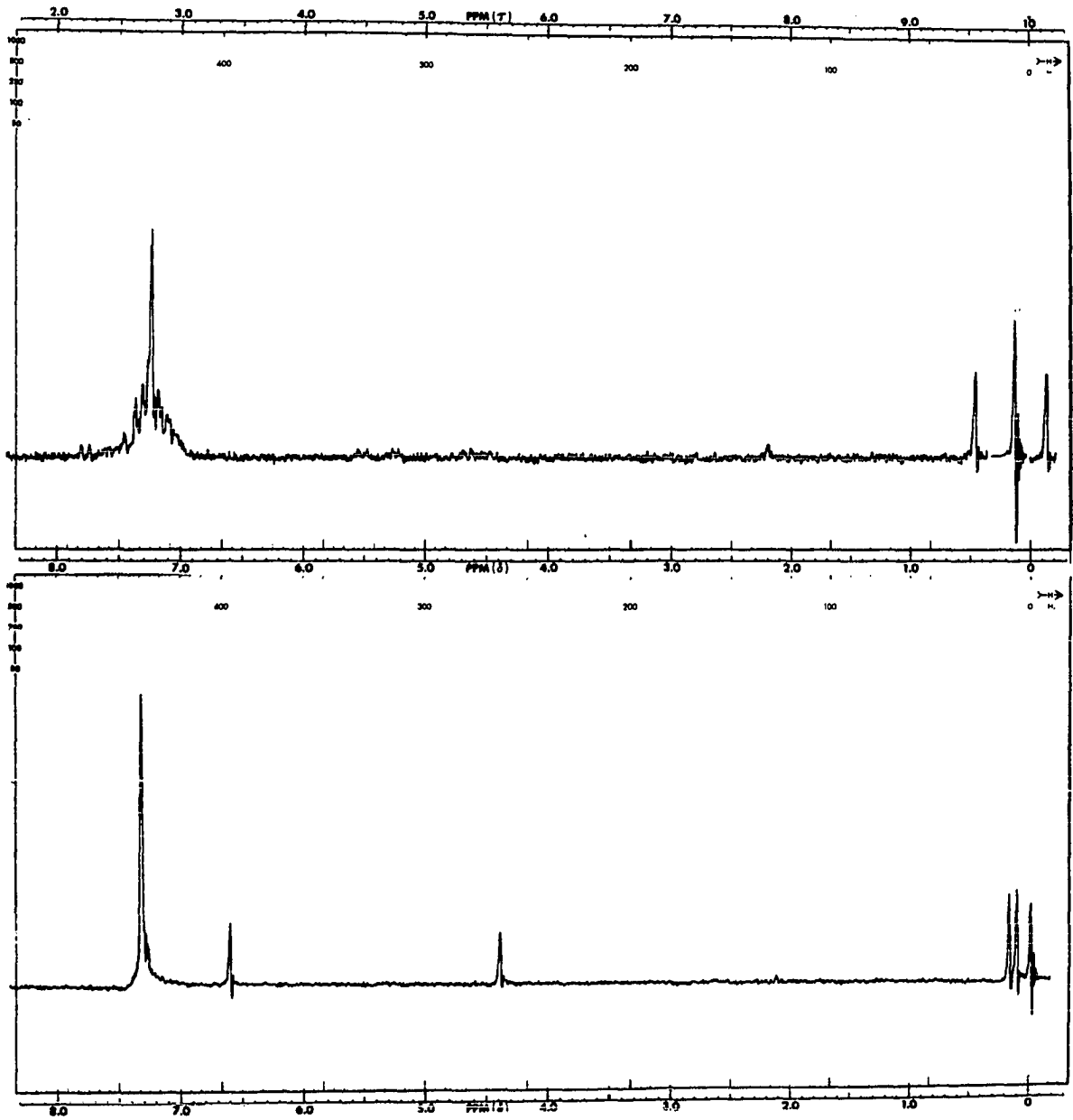

Figure 8a. 60 MHz NMR spectrum of phosphole-silole dimer 11

Figure 8b. 60 MHz NMR spectrum of silole-maleic anhydride Diels-Alder adduct 25



the mixed phosphole-silole dimer with an M⁺ at m/e 574. The NMR, shown in Figure 8a, is also consistent with such an assignment. It has an aromatic, olefinic multiplet of 27 protons with its center at δ 7.10. The methyl signals are a pair of singlets at δ 0.30 and δ -0.27 each being three protons. The phosphole 8 is capable of fluorescence and has a structure similar to 1. A pre-excitation complex of silole-phosphole is reasonable to assume and fits with the previous hypothesis concerning the dimerization mechanism. The product 11, although indicating cycloaddition could take place under the proper conditions, certainly was not one of particular interest. Therefore, it was not studied further.

Synthesis of a silepin from initial photocycloaddition

Corey found the masked ketene 1,1-dimethoxyethylene¹⁰⁹ 12 added in a 2+2 cycloaddition fashion to cyclohexenone when irradiated in an unsensitized manner. The thermal reaction of cyclopentadiene with ketene¹¹⁰ has also been investigated and found to yield a psuedo 2+2 cycloaddition product. These two examples and others led to the investigation of the reaction of the masked ketene 12 with 1.

Photolysis at wavelengths greater than 3000 Å of a ten-fold molar excess of 12 in ether with 1 gave only dimer 2. Photolysis under the same conditions of one molar

solutions of the silole 1 in 12 as a solvent also gave only dimer. At concentrations of 0.1 molar, however, 20 percent yields of an adduct 13 were observed along with ca. 20 percent yields of the dimer 2. At 0.05 molar concentrations 60 to 70 percent yields of the adduct 13 and little 2 were observed. All photolysis reactions were done through Pyrex and under nitrogen to avoid photooxidation of the silole 1.

The photoaddition of 12 to 1 is reversable as demonstrated by the decomposition of 13 to 1 at 2537 Å. A degassed 0.1 molar solution in a quartz NMR tube was photolyzed at 3000 Å. The NMR showed build-up of the dimer 1 with methyl signals at $\delta 0.31$ and $\delta -0.31$ and adduct 13 with methyl signals at $\delta 0.41$ and $\delta -0.21$ (see following section for structure assignment and NMR) at about equal concentrations. After six hours the ratio of 1 to 2 and 13 was about one to four indicating approximately eighty percent of the silole 1 had reacted. Photolysis of the resultant solution at 2537 Å destroyed the adduct 13 and dimer 2. The NMR showed only a clean silicon methyl resonance at $\delta 0.51$ for 1.

In order to illucidate the mechanism of dimer 2 and adduct 13 formation in the presence of 12, the rate of dimerization was studied at 1 molar concentrations. It was found that initial dimerization proceeds with an apparent second order rate constant of $7.36 \times 10^{-5} \text{ M.}^{-1}\text{sec.}^{-1}$ during

an initial time period of six hours. At ca. eight hours the dimer 2 concentration reached a maximum of 70 percent and stayed there. The graph of the concentration of 1 as a function of time is shown in Figure 9. The startling news about this rate constant is that it is ca. 10^{17} times slower than the dimerization in inert solvent. One possible explanation for the slowing of the dimer 2 formation is a competition between silole 1 and 12 for the excited singlet silole 1. Such a scheme may be illustrated as follows.

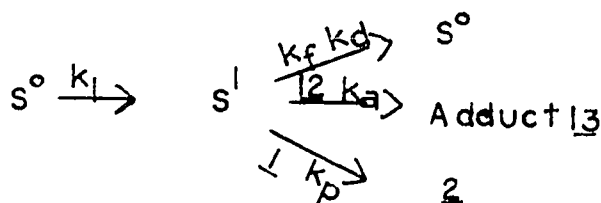

However, if simple competition were the case the following must be true. Assume the concentration of singlet silole 1 (S^1) to be a tenth of the silole 1 concentration, undoubtedly far too large, and the molarity of the solvent 12 to be 10. The rate expression for the process of dimer formation is

$$\frac{d[2]}{dt} = -k_a[S^1][12] + k_p[S^1][S] - (k_f + k_d)[S^1] .$$

At one molar concentration of 1 in 12 the only product observed was 2. Therefore, $d(2)/dt$ is approximately equal to $-d(1)/dt$, the rate which was plotted to give the apparent

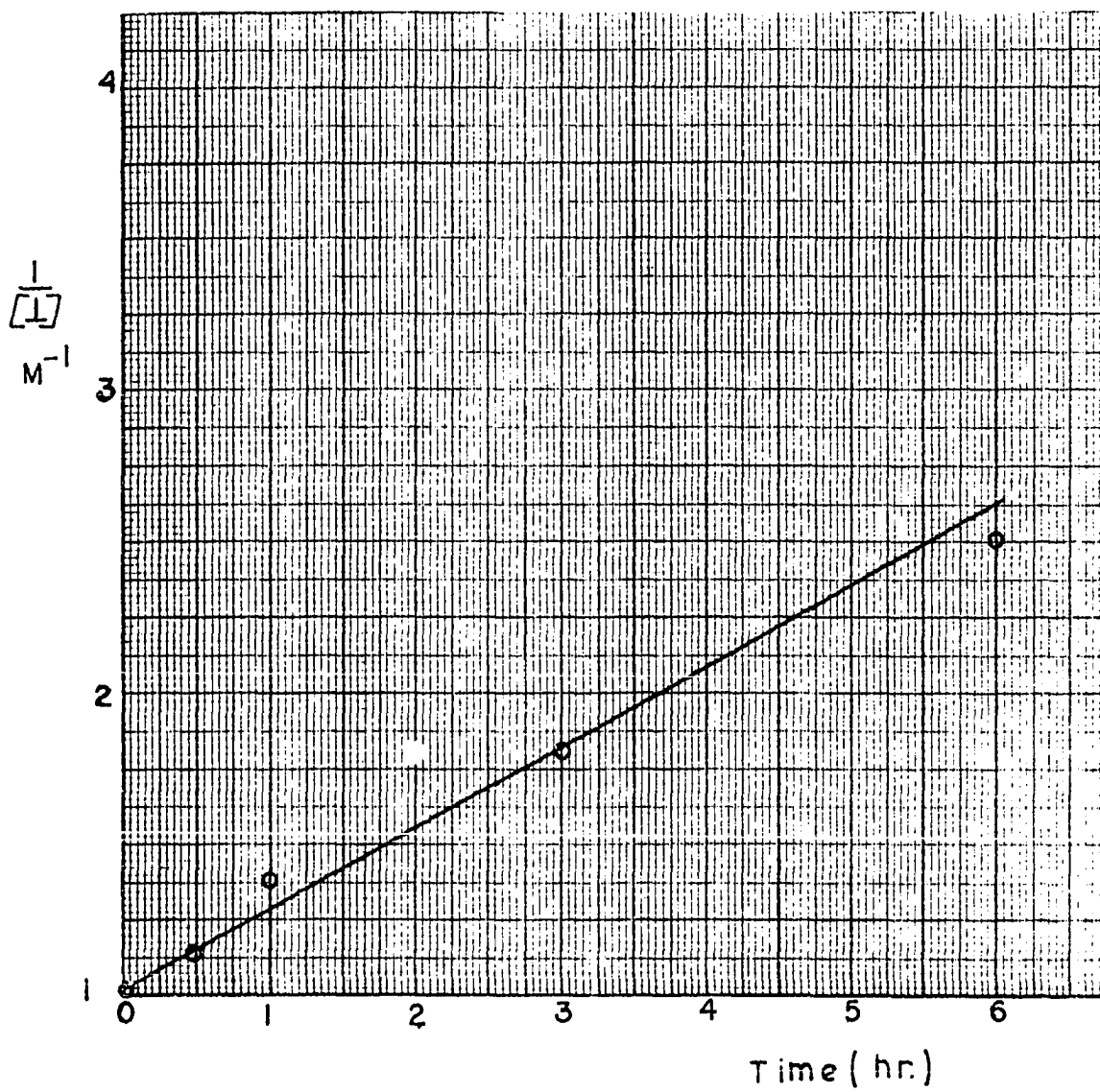

Figure 9. Plot of $1/[1]$ vs. Time

second order constant, i.e., $-d(1)/dt = (1)^2 k_{\text{apparent}}$.

Thus the rate expression becomes

$$(1)^2 k_{\text{apparent}} = -k_a(S^1)(12) + k_p(S^1)(S) - (k_f + k_d)(S^1).$$

Assuming the real dimer formation rate constant k_p has not changed from the inert solvent photolysis, the expression becomes

$$0.81M.^2(10^{-4}M.^{-1}sec.^{-1}) = -k_a(0.1M.)(10M.) + 10^{12}M.^{-1}sec.^{-1}(0.1M.) (0.9M.) - (k_f + k_d)(0.1M.)$$

Weiss found k_f+k_d to be ca. $10^8 sec.^{-1}$ which may be compared to fluorescence lifetimes of $10^{-8} sec.$ Rearranging the expression to find k_a , the following is given.

$$k_a = (9 \times 10^{10} M.^{-1}sec.^{-1} - 0.81 \times 10^{-5} M.^{-1}sec.^{-1} + 10^7 M.^{-1}sec.^{-1}) / 1M.^2$$

or

$$k_a \cong 9.001 \times 10^{10} M.^{-1}sec.^{-1}$$

This rate for adduct formation is only ten times smaller than that found for the dimer. At such large concentrations of 12, significant yields of the adduct 13 would then be expected.

It was proffered previously that there existed a pre-excitation complex of the silole 1 such that the rate of dimerization could be faster than diffusion controlled.

Since it has been established that the rate of adduct 13 formation is not comparable to the rate of dimer formation, then it is reasonable to postulate a complex existing between 1 and 12, also. Such a complex will readjust the equilibrium of the silole-silole complex formation. Since that complex is now at a much smaller concentration than expected, based on the concentration of 1, then the rate of reaction will be slowed without affecting the kinetic expression. Plotting concentration of 1 versus time will then give a lower apparent rate constant without changing the shape of the curve. The rate for adduct formation may then be orders of magnitude slower than the rate of dimer formation and still compete successfully with it. At concentrations of 0.05 molar 1 in 12, formation of the adduct 13 took times of ca. five to six hours; a rate much slower than dimer 2 formation is indicated. The postulated scheme is presented pictorially below.

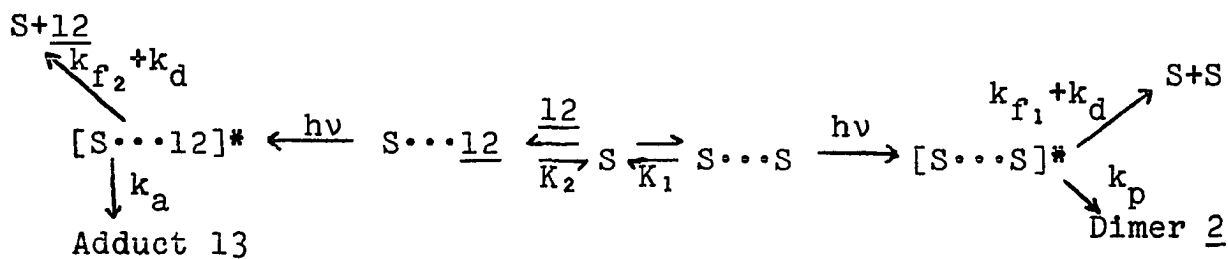

Proof of a pre-excitation complex needs further work.

However, the dramatic decrease in dimer formation found here points to some interesting possibilities.

Separation of the dimer 2 from the adduct 13 was accomplished by careful chromatography on silica gel. Two to four percent ether in hexane as an eluant served to give good separations if small fractions (50 ml) were collected. At higher concentrations of ether in hexane, ca. ten percent, the two components came off the column together. For subsequent reactions to convert the adduct 13 to the alcohol, separation need not be done at the ketal stage. The dimer is inert to the hydrolysis and reduction conditions. Crystallization of the resulting adduct 13 was difficult but achievable to give an analytically pure sample (mp. 82.5 - 84° C). The analysis and the mass spectrum confirmed the correct molecular weight of the adduct with an M⁺ at (m/e) 350. The adduct showed the expected facile cleavage across the fused cyclobutane ring in the mass spectrum to give the silole 1, (m/e) 262, which is the base peak of the spectrum. The stereochemistry of the adduct 13 was assigned from the NMR spectrum, shown in Figure 10 along with an expanded middle region of the spectrum. There is an aromatic and olefinic multiplet at δ 7.30 to δ 6.80 for those 11 protons. The doublet with its center at δ 3.70 has a coupling constant J_{ax} of 3.6 Hz, and is assignable to the allyl proton H_a. The singlet of δ 3.09 is assignable to the methoxy protons. The A,B pattern with centers at δ 2.74 and δ 2.42 has a coupling constant of -12 Hz and is assignable to the methylene

Figure 10a. 60 MHz NMR spectrum of the expanded middle region (120 Hz) of 13, the silole 1,1-dimethoxyethylene photoadduct

Figure 10b. 60 MHz NMR spectrum of adduct 13

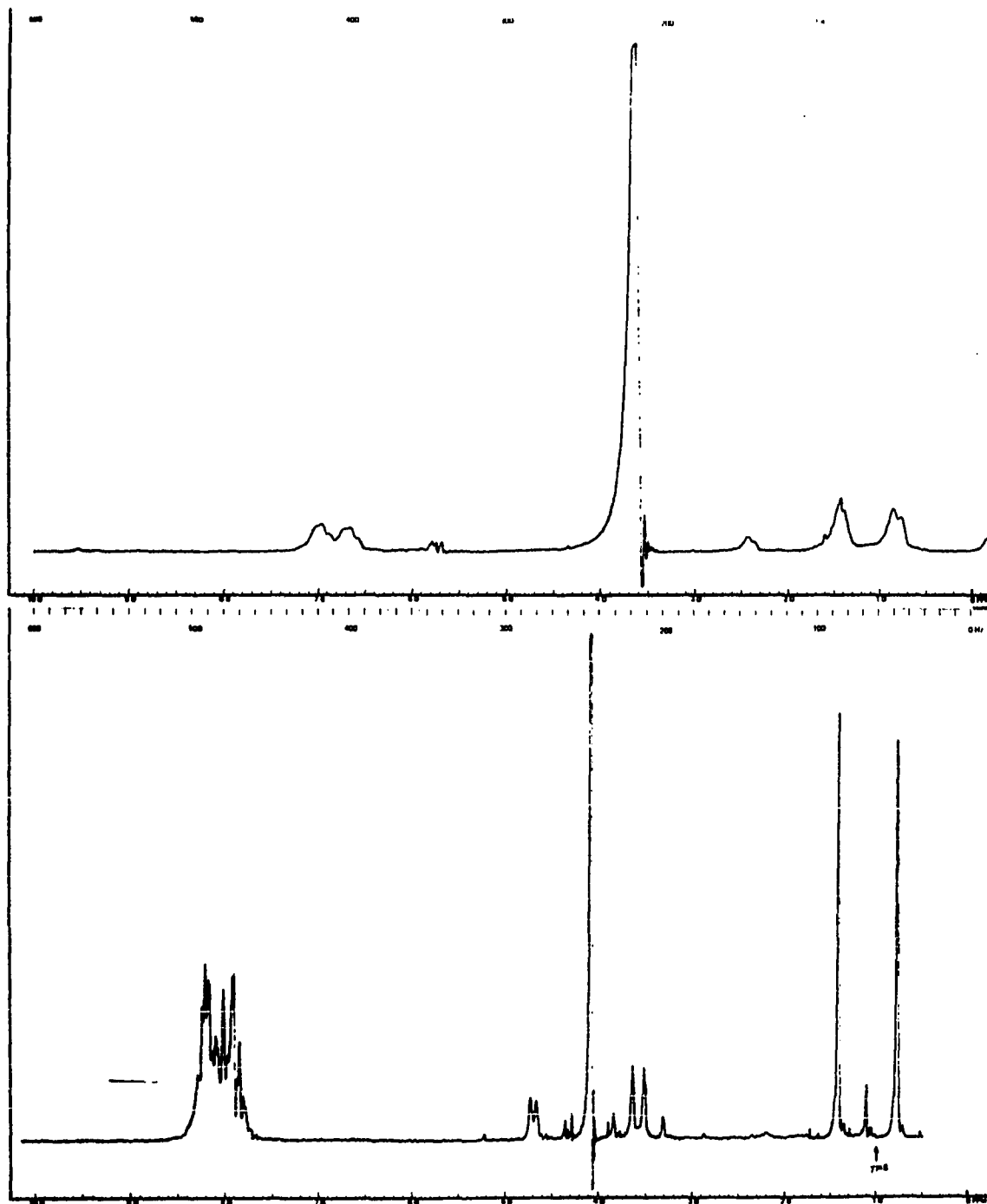

protons H_b and H_b' . The methyl signals are a pair of singlets at $\delta 0.41$ and $\delta -0.21$ and are three protons apiece. The allyl coupling J_{ax} is consistent with that found for the silole dimer 2. The gem coupling of the methylene protons H_b and H_b' occurred in the middle of the range -10.9 to -14 Hz quoted by Jackman¹¹¹ for cyclobutanes. A fine splitting of 2 Hz can be seen for the upfield signal of the pair. This coupling is due to the four bond coupling J_{ab} . Usually $J_{ab \text{ cis}}$ is larger than $J_{ab \text{ trans}}$ according to Jackman¹¹². Since the downfield signal has no fine splitting, then it is the trans proton H_b' . The upfield proton is H_b . The other rational structures are shown but are judged incorrect from the NMR spectrum. Configuration B would give a six line spectrum for the H_b, H_b' region. The Diels-Alder adduct C could not be correct for it would show a doublet of doublets in the olefin region 6.0 to 6.6, cf. the maleic anhydride Diels-Alder adduct NMR in Figure 9.

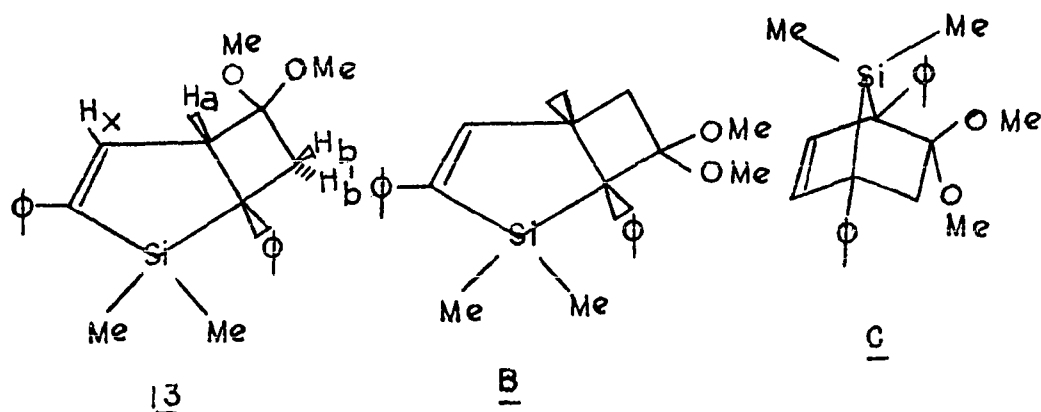

The infrared spectrum showed a very strong C-O stretch in the 1260 to 1250 cm^{-1} region consistent with the ketal assignment.

The ability to synthesize 1,1-dimethyl-2,7-diphenyl-5,5-dimethoxy-1-silabicyclo[3.2.0]hept-2-ene 13 in moderate to good yields provided a method by which the silepin may be synthesized. The reaction sequence is illustrated below. The necessary modifications to the proposed scheme are also shown to give an overall view to the following discussion.

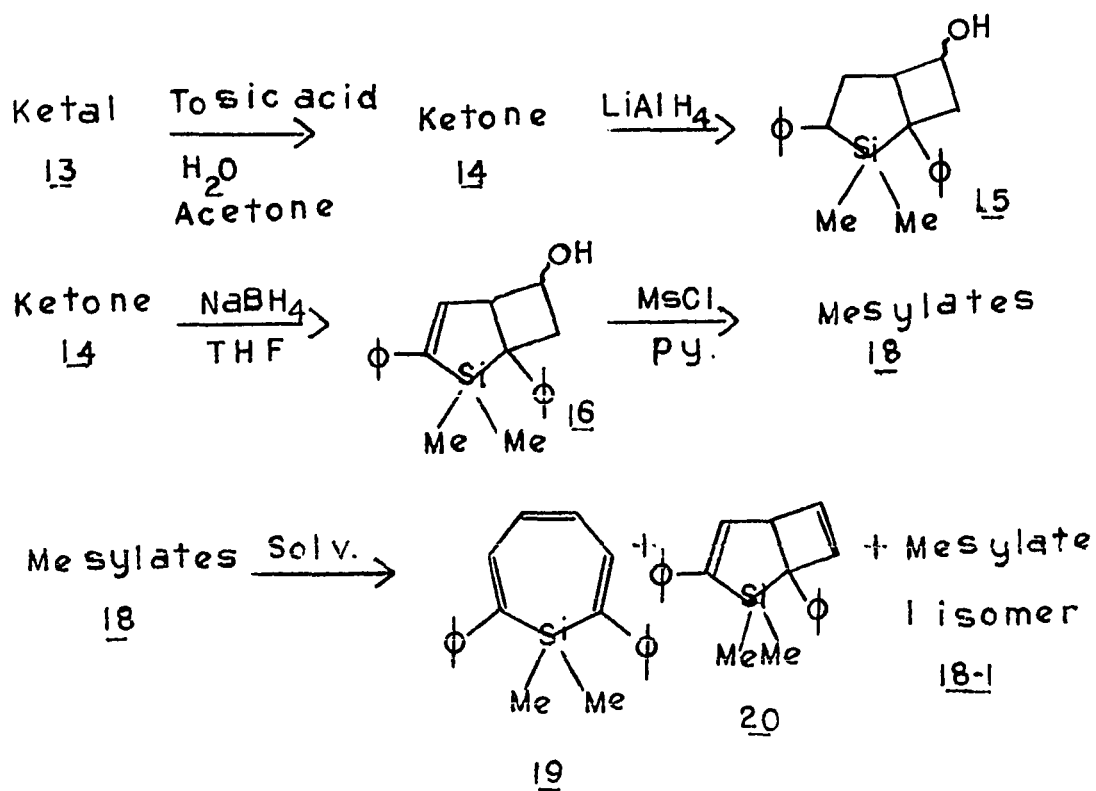

The rearrangement of the mesylate to the silepin is not, *á priori*, a simple elimination and ring opening, because of the presence of the fused cyclobutane ring^{113,114,115}. The mechanism is novel and is discussed in a later section.

The hydrolysis of the ketal was easily accomplished by refluxing overnight with reagent acetone, water and a catalytic amount of tosic acid. Workup in the usual fashion gave ketone 14 1,1-dimethyl-2,7-diphenyl-1-silabicyclo-[3.2.0]hept-2-en-5-one. The mass spectrum showed a parent ion at (m/e) 304 and a cleavage pattern indicating loss of a silicon methyl (m/e) 289 and loss of ketene to give the base peak of the spectrum, silole 1 (m/e) 262. Analysis of the IR spectrum indicated a four-membered ring ketone¹¹⁶ with a carbonyl stretch at 1785 cm⁻¹. NMR analysis showed no rearrangement had occurred. Revealed are an aromatic multiplet from δ 7.28 to δ 6.90 and an olefin doublet with its center at δ 6.86. The coupling constant J_{ax} is 4 Hz; together, the aromatic and olefinic signals integrated to 11 H. There was an octet with its center at δ 4.49 for the allyl signal H_a . The coupling constants are $J_{ax} = 4$ Hz, $J_{ac} = -1$ Hz, and $J_{ab} = -2$ Hz. Quartets with centers at δ 3.61 and δ 3.35 were assignable to the methylene protons H_b and H_c . The geminal coupling constant J_{bc} is 11 Hz. The two other small couplings are $J_{ca} = -1$ Hz and $J_{ba} = -2$ Hz. The methyl signals were a pair of singlets at δ 0.40 and δ -0.11

integrating three protons apiece. The four bond cis coupling of cyclobutanones¹¹⁷ has been found to be -1.9 Hz while the trans is smaller at -1.0 Hz. It is likely then that the 2 Hz coupling is between the cis methylene proton and H_a while the 1 Hz coupling is due to H_c , H_a spin interaction. The coupling of the methylene protons to the allyl proton would be reflected in the unequal fine splitting of the BC quartet. The downfield part of the quartet has a fine splitting of 2 Hz, while the upfield part has a fine splitting of 1 Hz. Therefore, the cis signal of H_b is downfield and the trans signal of H_c is upfield. The J_{bc} geminal coupling is again right in the middle of the range of that quoted by Jackman.¹¹¹

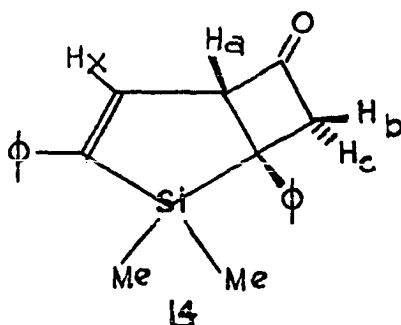

Reduction of the ketone 14 with lithium aluminum hydride in THF at room temperature gave an alcohol 15 which after purification gave the following spectral information. The NMR showed an aromatic, olefinic multiplet at $\delta 7.23$ to $\delta 6.77$, multiplets at $\delta 4.54$ to $\delta 4.18$, $\delta 3.90$ to $\delta 3.27$ and

δ 3.08 to δ 2.04 and singlets for the methyl signals at δ 0.38 and δ -0.26, equal intensity, and δ 0.11 and δ -0.55, equal intensity. The two sets of singlets for the methyl signals indicated both the endo and exo alcohols were formed. Assignments were not possible from the NMR data. The infrared spectrum had a typical alcohol O-H stretch from 3600 to 3140 cm^{-1} and a C-O stretch from 1095 to 1060 cm^{-1} . The mass spectrum provided startling evidence concerning the reaction product. Comparison of the 70 and 16 eV. spectra showed the molecular weight to be 308. Reduction of the carbon-carbon double bond had occurred in addition to carbonyl reduction. Reduction of unsaturated ketones is somewhat unusual but explainable¹¹⁸. The effects of an electropositive silicon on one side and a carbonyl on the other side of the double bond served to polarize the bond so as to permit its reduction.

Reduction of ketone 14 with sodium borohydride in THF gave 1,1-dimethyl-2,7-diphenyl-1-silabicyclo[3.2.0]hept-2-en-5-ol 16. Purification could be achieved by chromatography on a short column of silica gel. Elution with 10 percent ether in hexane removed all nonpolar impurities such as dimer. Fifty percent ether in hexane removed 16. Care must be taken for ether elution will remove the more polar impurities, most likely hydrolysis products from 12 left in

the ketal solution. Washing a methylene chloride solution of chromatographed 16 with 1.0 N. hydrochloric acid caused partial rearrangement to p-terphenyl. The p-terphenyl (mp 206 to 208° C) could be fractionally crystallized from the alcohol 16, p-terphenyl solution and gave the correct spectral evidence. For comparison o-terphenyl melts at 58° C, m-terphenyl at 87° C, and p-terphenyl at 211° C¹¹⁹. The rearrangement of the alcohol 16 to p-terphenyl will be discussed after the spectral evidence for the alcohol. Careful washing of the crude reaction material with water to get rid of excess sodium borohydride followed by chromatography on a large column of silica gel gave 40 to 60 percent overall yields of the endo and exo mixture of 16.

The NMR of 16 is rather complex owing to the presence of two stereoisomers. However, all the signals are assignable. The NMR had an aromatic and olefinic region at $\delta 7.41$ to $\delta 6.80$ integrating for 22 protons. There were four slightly broadened lines centered at $\delta 4.42$. They most likely are an AX₃ pattern with the three coupling constants accidentally the same, $J_{ab} = J_{ac} = J_{ac'} = 8$ Hz. This absorption was assignable to the hydroxymethine proton H_a of one of the isomers. The other stereoisomer signal from H_a was a partially obscured doublet of triplets with its center at 3.80. The coupling constants of 4.5 Hz and 8 Hz are attributable to J_{ab} and $J_{ac} = J_{ac'}$, respectively. J_{ab}

is assignable because of its appearance in the splitting pattern for H_b at $\delta 3.40$. The concentrations of the two isomeric alcohols 16 were not the same. Therefore the ratio of the two types of hydroxymethine H_a signals was not one. But the total ($1.5 H + 0.5 H = 2 H$) balanced with the other integrations. The vicinal coupling constant in cyclobutanes has no clear pattern according to Jackman¹²⁰. The range is 4 to 13 Hz. Further there is no clear cut pattern concerning the relative values of J_{cis} and J_{trans} . Such values usually suffer from conformational preference. The observed couplings at 4 and 8 Hz are all within the cited range. The same coupling constant for J_{cis} and J_{trans} is at least consistent with the data presented by Jackman. The multiplet at $\delta 3.91$ centered and the broadened triplet centered at $\delta 3.40$ were assignable to the two stereoisomeric allyl protons H_b . The H_b multiplet at $\delta 3.91$ overlapped with that at $\delta 3.80$ but the triplet $\delta 3.40$ has a coupling constant of $4.5 \text{ Hz} = J_{ab}$. The two three-bond couplings J_{ba} and J_{bx} affecting H_b are most likely not the same. The triplet is not sharp but broad, indicating close but not equal couplings. The multiplet at $\delta 2.98$ to $\delta 2.30$ may be assigned to the hydroxyl and cyclobutyl methylene protons H_c and H_c' . It was badly split but addition of D_2O reduced its intensity. The silicon methyl resonances can not be assigned as pairs because the

downfield resonances of each fortuitously overlapped to give a slightly broadened singlet at $\delta 0.34$. The upfield resonances at $\delta -0.21$ and $\delta -0.28$ were unequal in intensity. The total integration of the silicon methyl region balanced with the rest of the spectrum.

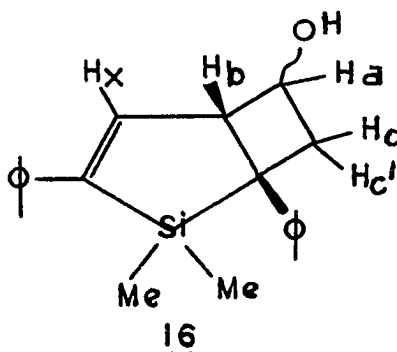

The infrared spectrum clearly indicated an alcohol with an O-H stretch at 3600 to 3260 cm^{-1} and C-O stretch at 1120 to 1080 cm^{-1} . No residual ketone absorption was found. The mass spectrum indicated a cleavage preference through loss of acetaldehyde to the silole (m/e 262) as the base peak of the spectrum. The molecular ion is clearly at m/e 306 as demonstrated by its growth in the 20 eV. spectrum. The exact mass analysis in lieu of an elemental analysis was within the expected limits.

Reaction of the alcohol 16 with *p*-nitrobenzoylchloride in pyridine afforded an 87 percent yield of the stereoisomeric mixture of 1,1-dimethyl-2,7-diphenyl-1-silabicyclo-[3.2.0]hept-2-en-5-*p*-nitrobenzoates 17. The NMR, shown in

Figure 11b, is much clearer with this derivative. The aromatic singlet at $\delta 8.08$ (8 H) is assignable to the p-nitrobenzoate. The aromatic, olefinic multiplet occurs at $\delta 7.44$ to $\delta 6.80$ and one of the olefinic signals is at the side of the aromatic absorption as a doublet at $\delta 6.82$ center, J_{xb} equal to 3 Hz. The AX_3 pattern at $\delta 5.48$ (1 H) is assignable to the hydroxymethine proton H_a . That the coupling constants J_{ab} , J_{ac} , $J_{ac'}$ are all equal to 8 Hz is accidental but reasonable. The expanded spectrum shows each peak of the signal at $\delta 5.48$ to be unresolvable multiples, indicating the coupling constants affecting that proton are approximately equal. The other stereoisomer's hydroxymethine H_a shows an AMX_2 with six lines forming a doublet of triplets. The coupling constant of 7 Hz is assignable to the vicinal coupling J_{ac} and $J_{ac'}$. The other coupling constant J_{ab} is equal to 4.8 Hz and is equal to J_{ba} for that isomer. The equality of vicinal cis and trans coupling constants has been found in other cyclobutanes as well^{121,122,123}. Georgian¹²¹ reported such results in the analysis of the NMR spectrum of cis-1,2-dicarboxy-trans-3,4-dibromocyclobutane¹²⁴. The doublet of doublets at $\delta 4.21$ (1 H) is coupled to the quartet at $\delta 5.48$ with a coupling constant J_{ba} of 8 Hz. That peak is the resonance from one of the allyl protons and couples with the olefin proton $\delta 6.82$ with J_{bx} equal to 3 Hz. This allyl coupling is a bit small compared to the normal range of

Figure 11a. 60 MHz NMR spectrum of isolated mesylate isomer 18-1

Figure 11b. 60 MHz NMR spectrum of the mixture of benzoates 17

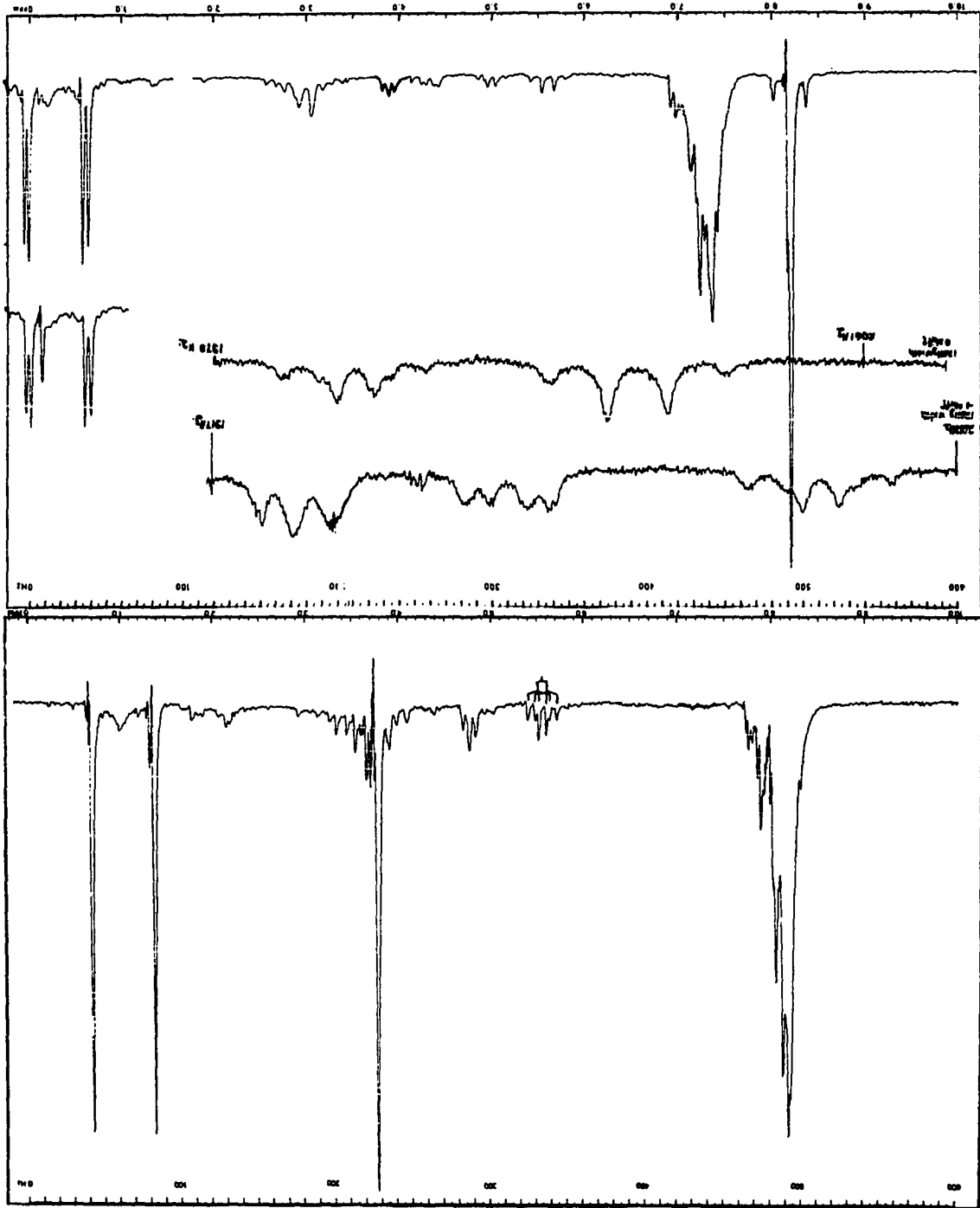

allylic couplings, 4 to 10 Hz, but it is consistent with the ketone 14, ketal 12, dimer 2, and the model compound already quoted. The other isomer's allyl signal occurs at $\delta 3.75$ (1 H) and is an AX₂ triplet pattern with J_{bx} equal to J_{ba} equal to 4.8 Hz. The expanded spectrum shows that each peak of this proton's resonance is actually an unresolvable multiplet. The difference in the olefin-allyl proton coupling J_{bx} for this isomer as compared to the other (3 Hz) is due to the conformational difference of the cyclobutane ring. The desire of the p-nitrobenzoate to the equatorial in both isomers¹²⁵ forces a different dihedral angle upon H_x-C-C-H_b. According to the Karplus rule this change should affect the coupling constant. The multiplet from $\delta 3.18$ to $\delta 2.44$ (4 H) happens at the right chemical shift for cyclobutyl protons. The pattern is symmetric but complex with each half a mirror image of the other. This type of symmetry is common for AB patterns which the methylene protons should exhibit.

The chemical shift assignments were also demonstrated by an NMR irradiation experiment on the mixture of benzoate isomers 17. Irradiation at the downfield quartet $\delta 5.48$ caused collapse of the doublet of doublets at $\delta 4.21$ to a broad multiplet. Irradiation at $\delta 6.82$ caused collapse of the same doublet of doublets $\delta 4.21$ to a doublet, J_{ba} equal to 8 Hz. Clearly the small doublet at the side of the aromatic absorption is due to the olefin proton H_x from one of the isomers.

Irradiation at $\delta 6.90$ caused collapse of the triplet $\delta 3.75$ to a doublet J_{bx} equal to 4.8 Hz. Irradiation at $\delta 4.85$, the upfield doublet of triplets, caused collapse of the triplet $\delta 3.75$ to a broad multiplet. Irradiation at $\delta 2.70$ caused partial collapse of the doublet of triplets $\delta 4.85$ to a triplet. These irradiations indicate one isomer has NMR resonances at $\delta 6.80$ H_x , $\delta 5.48$ H_a , $\delta 4.21$ H_b and $\delta 3.18$ to $\delta 2.44$ H_c and $H_{c'}$. The other isomer has NMR resonances at $\delta 6.90$ H_x , $\delta 4.86$ H_a , $\delta 3.75$ H_b and $\delta 3.18$ to $\delta 2.44$ H_c and $H_{c'}$.

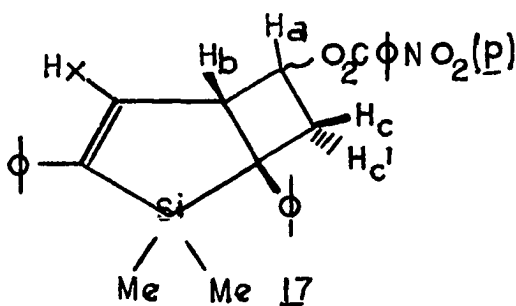

The methyl signals are clearly resolved into four singlets at $\delta 0.50$, $\delta 0.44$, $\delta -0.14$ and $\delta -0.20$. The peaks may be paired in this case due to the equal intensity pairs. The outer pair belonged to one isomer, the inner pair to the other. The total number of protons was correct, 12, for the sum of both isomers.

The infrared spectrum showed stretches at 1735 and 1295 to 1250 cm^{-1} for the benzoate carboxyl. The nitro group is also evident from absorptions at 1540 and 1360 cm^{-1} .

The mass spectrum indicated the correct molecular weight at (m/e) 455 in the 16 eV. spectrum. The facile cleavage of the p-nitrobenzoate to give the alkoxy fragment at (m/e) 305 is common for aromatic esters¹²⁶.

Since p-nitrobenzoates of fused cyclobutane rings take a very long time and high temperature (sealed tube) to solvolyze in 80 percent aqueous acetone¹¹⁴, it was decided to study the solvolysis of a faster reacting derivative, the mesylate 18. Reaction of mesyl chloride with 16 in dry pyridine resulted in the formation of pyridine hydrochloride indicating the reaction was taking place. After workup in the usual fashion, extraction with dilute hydrochloric acid, an NMR of the residue showed two sharp silicon methyl singlets at $\delta 0.47$ and $\delta -0.20$ of equal intensity. There was also a broad silicon methyl singlet at $\delta 0.14$ which had a line width of 0.10 ppm. It appeared the reaction material was rearranging or had already reacted because an NMR of the same material after storing overnight at -20°C showed no further change. The mesylate was solvolyzed without further adieu in 90 percent aqueous acetone with urea as a buffer for the acid produced. After solvolysis for two days at $52^\circ \text{C} \pm 3^\circ \text{C}$, the reaction material was worked up. The NMR of the

resultant oil was the same as that before the solvolysis reaction. The reason there were only three silicon methyl signals now became apparent. One isomer of the pair of mesylates 18 rearranged very quickly, most probably during its formation in the pyridine solvent. The other mesylate isomer was stable to the formation and solvolysis reaction conditions, which employed typical procedures for such a supposedly reactive compound as cyclopropyl carbonyl tosylate¹²⁷. This remarkable difference in rate of reaction will be discussed later in the mechanism section.

Chromatography of the reaction material on silica gel gave three products, two silicon containing hydrocarbons and the one mesylate 18 isomer.

One percent ether in hexane removed the first silicon hydrocarbon, 1,1-dimethyl-2,7-diphenylsilepin 19. It has the following spectral characteristics. The NMR, shown in Figure 12, has an aromatic multiplet from $\delta 6.93$ to $\delta 6.86$ integrating for 10 protons. There is an AA'BB' pattern with centers at $\delta 6.79$ and $\delta 6.52$, four protons total, two each for the halves of the pattern. The coupling constants are J_{ab} equal to J_{ba} equal to 2.8 Hz and $J_{ab'}$ equal to $J_{a'b}$ equal to 4.5 Hz. The methyl signals occur as a singlet at $\delta 0.09$ and integrate for six protons. Analysis of the olefin region is more complex than apparent for the assignment has left out $J_{aa'}$ and $J_{bb'}$, the coupling constants between

Figure 12a. 60 MHz NMR spectrum of 1,1-dimethyl-2,7-diphenylsilepin 19

Figure 12b. 100 MHz NMR spectrum of 19
(lock on TMS which blots out the silicon methyl signals)

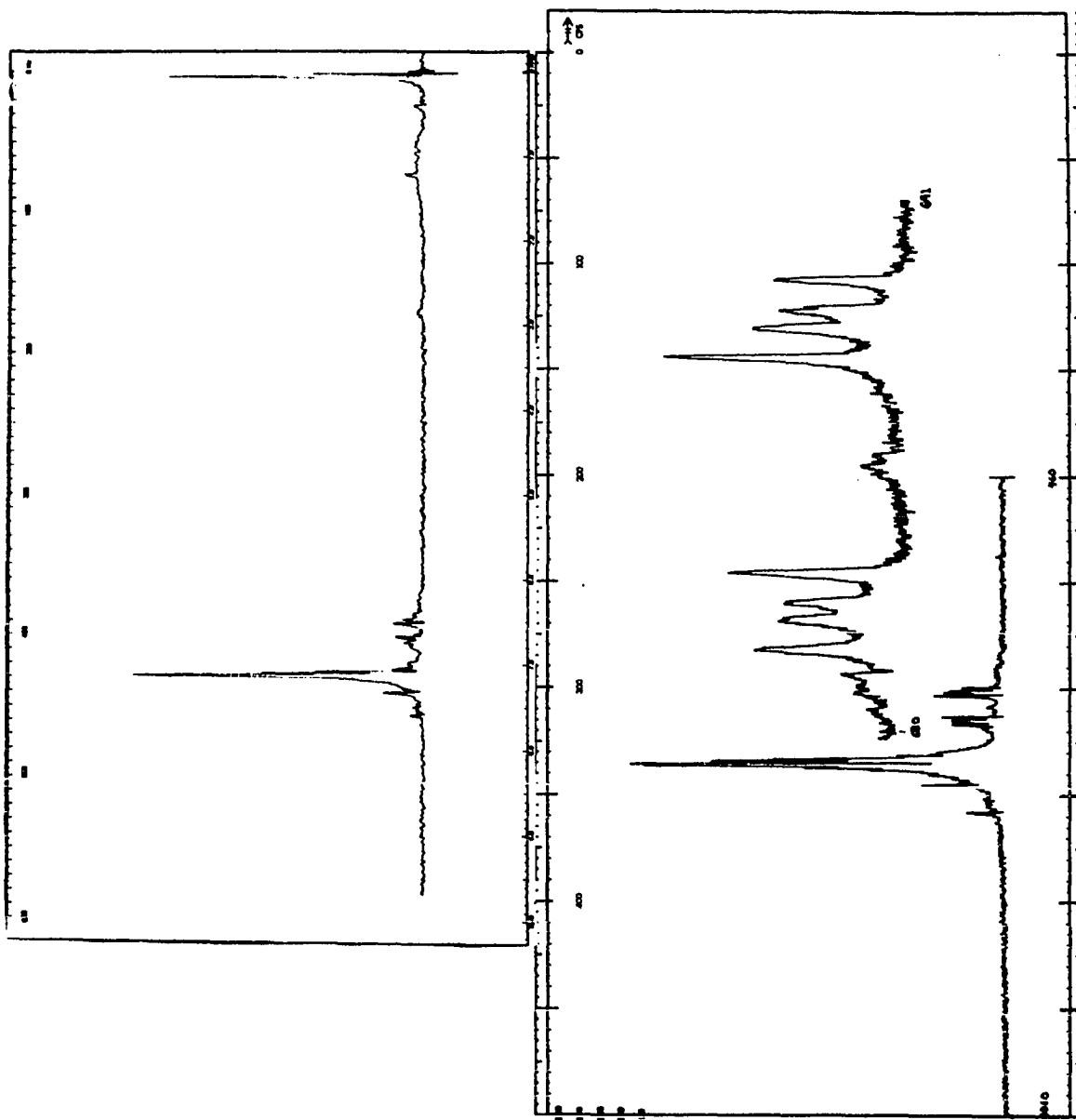

the isochronous but not magnetically equivalent protons. Observation of the expanded olefin region revealed each of the large resonances to have shoulders and/or be composed of two very close resonances. The best analysis is comparison to a model compound, 1,2,7-triphenylcycloheptatriene¹²⁸ which has the same olefin region pattern. A correct exact mass analysis was obtained at m/e 288.1342, cf., 288.1334 calc'd. and the mass spectrum showed metastables for the loss of methyl from silicon and loss of dimethyl silylene from the parent ion. The silylene loss is indicative of the cycloheptatriene-norcaradiene tautomerism. Expulsion of the silylene to form the aromatic o-terphenyl is reasonable.

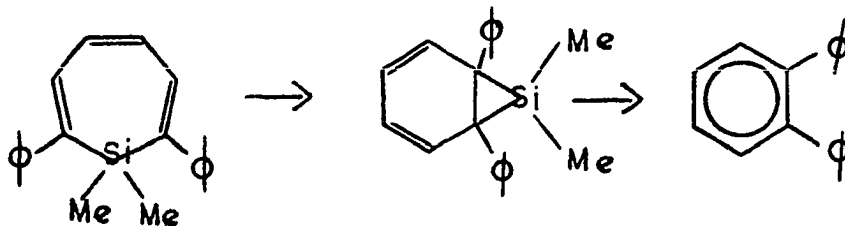

There was no (m/e) at 262, silole 1, which is consistent with the silepin 19 ring system.

The second silicon hydrocarbon 20 was obtained by elution with 1 percent ether in hexane elution too. Rechromatography on a silica gel prep TLC plate gave relatively pure compound with the following NMR, aromatic singlet which was slightly broadened occurred at $\delta 7.14$ with a doublet at $\delta 7.02$. Together these peaks integrated for 11 protons. There were

small unresolvable multiplets at $\delta 6.40$ and $\delta 6.35$ (centers) integrating for three protons and a broad singlet at $\delta 0.10$ (6 protons). The molecular weight, UV spectrum and infrared spectrum all indicated this compound was not o,m or p-terphenyl, 1,6-diphenylhexa-1,3-dien-5-yne¹²⁹, silole 1, or 2,5-diphenylhexa-1,5-dien-3-yne¹³⁰ mixed with silicone stopcock grease. The mass spectrum indicated a molecular weight of 288, an isomer of the silepin 19. However, it showed facile cleavage to (m/e) 262, silole 1. Also, shown were the loss of methyl to give (m/e) 273, the characteristic dimethyl loss from silole 1 to give (m/e) 232 and the loss of dimethyl silylene from the parent to give (m/e) 230. Reviewing the silicon methyl region of the NMR, it was determined that the line shape was two very close singlets superimposed upon a somewhat broadened singlet silicon methyl background.

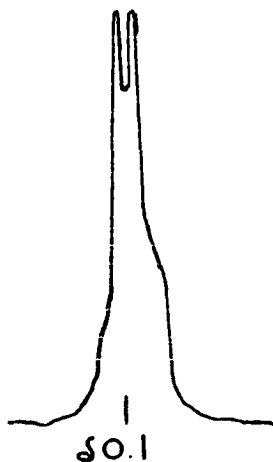

line shape of the silicon methyl region of 20

The exact mass analysis gave a molecular formula of $C_{20}H_{20}Si$. This evidence dictated that the compound was 1,1-dimethyl-2,7-diphenyl-1-silabicyclo[3.2.0]hepta-2,5-diene. This compound should show facile cleavage of the cyclobutene ring to give silole 1 in the mass spectrum. The methine signal in the fused cyclobutene ring should have a chemical shift of ca. 6.3, found by adding up the effects of the various substituents. The closeness of the methyl signals is somewhat surprising in view of the precursors. However, the conformation of the cyclobutene ring probably pulls the bridgehead phenyl down toward the plane of the five-membered ring enough so that the silicon methyl is not in the deshielding cone anymore.

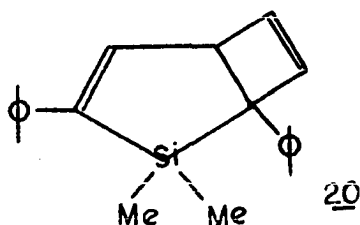

The third product, obtained by elution with 50 percent ether in hexane, was one unrearranged mesylate isomer 18. The mass spectrum had no parent ion but showed loss of 31, CH_3O , to give (m/e) 353. The next loss is 48 and is either a loss of SO from (m/e) 353 or a loss of SO_2CH_3 from the parent ion. That the mesylate 18 showed no parent ion is reasonable according to Djerassi¹³¹, "In general the parent

ions are of low abundance (1-3%) or absent...". The NMR may be superimposed on that of the mixture before solvolysis and all the peaks match up. The NMR of 18, shown in Figure 11a, has an aromatic, olefinic multiplet at $\delta 7.38$ to $\delta 6.80$ (11 protons). There is a doublet of triplets at $\delta 4.62$ center with the coupling constants J_{ac} equal to J_{ac} , equal to 7.5 Hz and J_{ab} equal to 5 Hz. This resonance is assignable to the mesyl methine proton H_a . There is a broadened triplet at $\delta 3.83$ center with J_{bx} approximately equal to J_{ba} equal to 5 Hz and is the resonance from the allyl methine proton H_b . There is a multiplet from $\delta 3.07$ to $\delta 2.36$ with a singlet right in the middle at $\delta 2.88$. Together they integrate for 5 protons and are assignable to the cyclobutyl methylene protons H_c and H_c' , and the mesyl protons. The Si methyl peaks come as two singlets of equal intensity at $\delta 0.47$ and $\delta -0.21$ and each integrate for 3 protons. The assignments are rea-

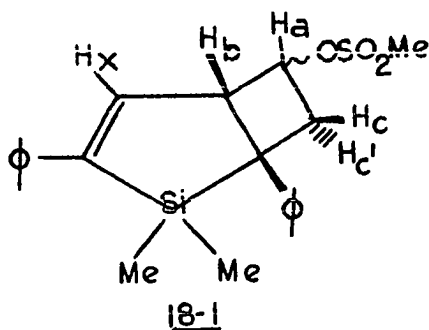

sonable upon comparison with the alcohol 16 and the benzoate 17. The infrared spectrum clearly showed the presence of a sulfonate¹³² with absorptions at 1380 to 1330 cm^{-1} and 1190

to 1170 cm^{-1} . This mesylate after purification was solvolyzed for three days in 80 percent aqueous ethanol using urea as a base. There was no change in the NMR spectrum of the compound after workup.

Low temperature NMR studies on the silepin 19 in carbon disulfide revealed silicon methyl line broadening at -95° C . This broadening was presumably due only to the increasing viscosity of the solvent (mp -108.6° C). At no time was the resolution of the silicon methyl singlet into a set of two resonances observed. The coalescence temperature of various phenyl substituted tropylienes is in the range -80 to 40° C ¹³³. On this basis it must be said that the silicon methyl resonances of 19 in a boat conformation fortuitously overlap or that the silepin 19 is indeed a planar molecule.

The influence of the dihedral angle $\text{H}_a\text{-C}_3\text{-C}_4\text{-H}_b$ on the coupling constant J_{ab} should give some indication of the planarity of the ring. Jackman¹³⁴ has discussed the influence of sp^2 carbons on such constants. The cis or trans nature of the olefin maintains a very large effect on the coupling. Trans-trans butadiene derivatives generally have a coupling $J_{b'b}$ of 10 to 12 Hz while cyclopentadiene has a coupling $J_{b'b}$ of 1.94 Hz. However, as the dihedral angle approaches 90 degrees from either direction, the coupling constant goes down¹³⁵. Unfortunately, there are no planar model compounds with which to compare the silepin 19. The exact answer of

the planarity or lack of it is currently under investigation by X-ray techniques. The crystal structure will certainly provide an answer.

Two ring opening mechanisms are possible to produce the silepin 19. The first is direct conversion through disrotary opening of the bridge cyclobutane bond. The second is elimination of acid to form a cyclobutene and non-concerted opening of it to 19. Although the concerted, thermal

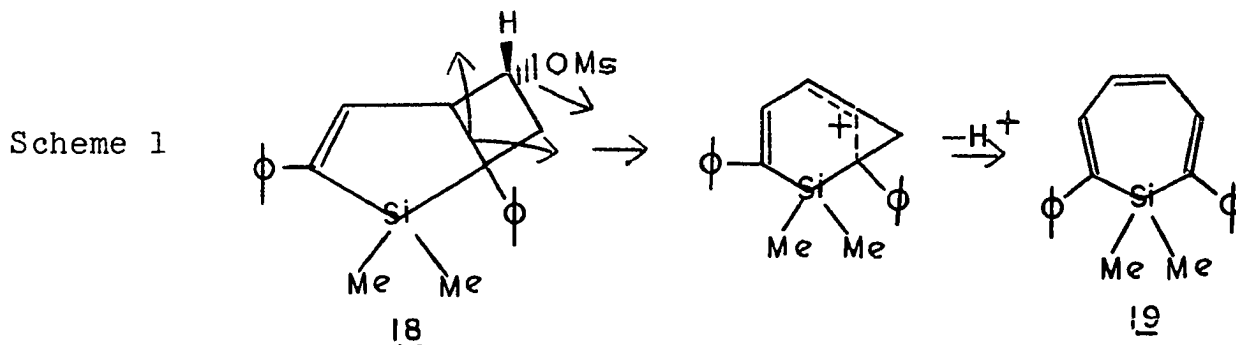

disrotatory ring opening of a cyclobutene is unallowed, such a process may take place through a diradical. It is reasonable to write that slow conversion of 20 to 19 happened under the reaction conditions employed since the mechanistic intermediate 20 was isolated from the reaction mixture. To this end a sample of purified 20 was refluxed in carbon tetrachloride for three days. Isolation of the reaction

material followed by spectral investigation of it showed no rearrangement of 20 to 19 had occurred. This observation is supported by the fact that cyclobutenes are usually stable to ring opening at low temperatures, ca. 60° C.¹¹³

The rearrangement of the alcohol 16 to p-terphenyl has an indirect bearing on the mechanism given in Scheme 1. Production of the p-terphenyl has two possible mechanisms from the cyclobutyl cation. A 1,3 shift of the silicon carbon bond, ring opening to the silepin 21, ring closure to the silanorcaradiene 22 followed by silylene expulsion to give p-terphenyl, or participation of the carbon-carbon double bond to give a [2.2.1] silanorbornadiene 23 which then suffers the well documented* silylene expulsion.

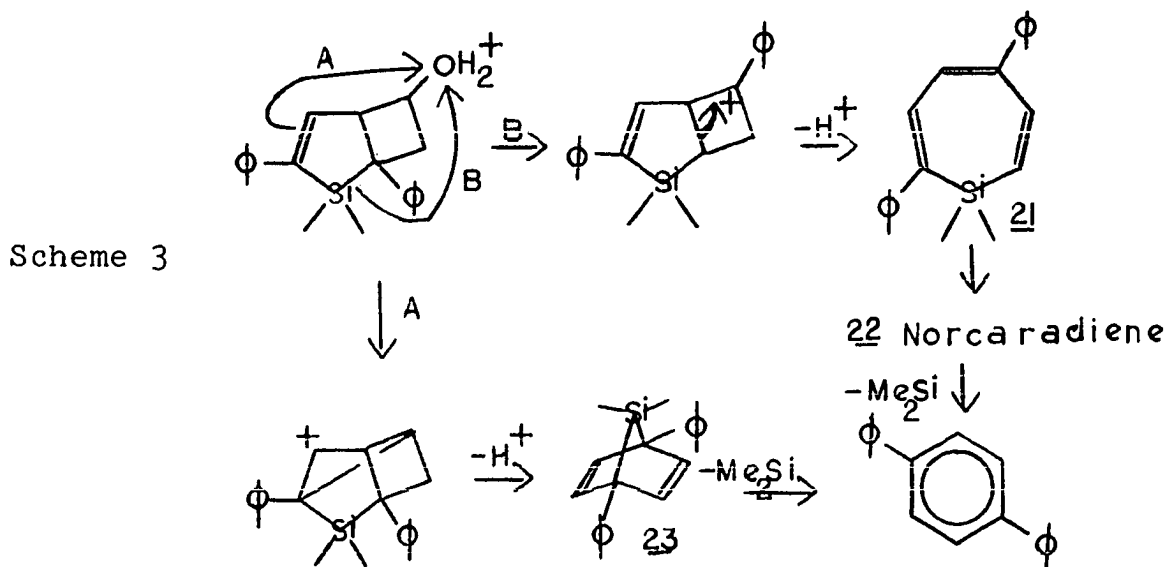

*See page 112.

The fact that no p-terphenyl was isolated from the mesylate 18 reaction to give 19 dictates a different pathway for the cyclobutane ring opening from the mesylates 18 than that of the protonation of the alcohol during acid workup, scheme 3, i.e., participation of the silicon-carbon bond or the carbon-carbon double bond.

Although one of the isomers of the pair of mesylates 18 was not isolated, but rearranged immediately upon formation, the conclusion may still be made that the rates of solvolysis are significantly different. Such results have been found for all-carbon fused cyclobutane rings¹³⁶, also. Nelson¹³⁷ has solvolyzed endo and exo bicyclo[3.2.0]heptanyl-5 tosylate and found $k_{\text{endo}}/k_{\text{exo}}$ to be equal to 500. Increase in strain by going from the [3.2.0] to the [2.2.0] to the [2.1.0] systems was found to increase the ratio to 10^8 . It, therefore, becomes imperative to assign the stereochemistry of the unrearranged mesylate isomer. Is it endo or exo? Analysis may be based on the comparison of the coupling constant J_{ab} and the chemical shift of H_a for the mixture of benzoates 17 and the unreacted mesylate 18.

The benzoate mixture 17 has the following values for the proton H_a and couplings J_{ab} .

Benzoate 17-1 H_{a1} $\nu = \delta 5.48$ $J_{ab1} = 8 \text{ Hz}$

Benzoate 17-2 H_{a2} $\nu = \delta 4.86$ $J_{ab2} = 4.8 \text{ Hz}$

The mesylate 18-1 has the following spectral values.

$$\text{Mesylate } \underline{18-1} \quad \nu = 84.62 \quad J_{ab1} = 5 \text{ Hz}$$

Clearly the unreacted mesylate 18-1 corresponds to benzoate 17-2. The line shape for the equal H_a protons is a doublet of triplets, cf. Figure 10, while the line shape for 17-1 is a quartet.

The stereochemistry of 17-1 and 2 may be assigned using both parameters. The coupling constant gives only an indication of the correct stereochemistry because of the inability to discern a vicinal coupling pattern in cyclobutanes¹³⁸. However, the shift value is conclusive. The Karplus equations relating dihedral angle to coupling constant are,

$$J = J^0 \cos^2 \phi - C \quad 0^\circ < \phi < 90^\circ$$

$$J = J^0 \cos^2 \phi - C \quad 90^\circ < \phi < 180^\circ$$

The assumptions are made that J^{180} equals J^0 , a valid assumption based upon Georgian's work¹³⁹, and the conformation of the cyclobutane ring is close to planar to accommodate the phenyl, the dimethyl silicon and p-nitrobenzoate groups in equatorial positions. Constructing such a molecule from models indicated that H_a and H_b in a cis geometry had a dihedral angle close to zero. The other geometry with H_a and H_b trans had a dihedral angle of about 20 to 30 degrees away from 180° . Therefore J_{ab} trans should be smaller than J_{ab} cis. On this basis 17-2 has H_a and H_b trans and is the

exo-benzoate 17. The chemical shift difference between Ha of 17-1 and 17-2 confirms this conclusion. Ha in a cis configuration with Hb is not near enough to the 7-phenyl ring to be either shielded or deshielded. Ha in a trans configuration with Hb points directly into the shielding cone of the carbon-carbon double bond of the fused five-membered ring. Therefore, Ha trans should experience an upfield shift in the NMR and does to the order of 0.62 ppm upfield from Ha cis. The mesylate 18-1, which did not solvolyze, was the exo mesylate 18. The NMR's of the exo and endo benzoates 17 are tabularly shown below.

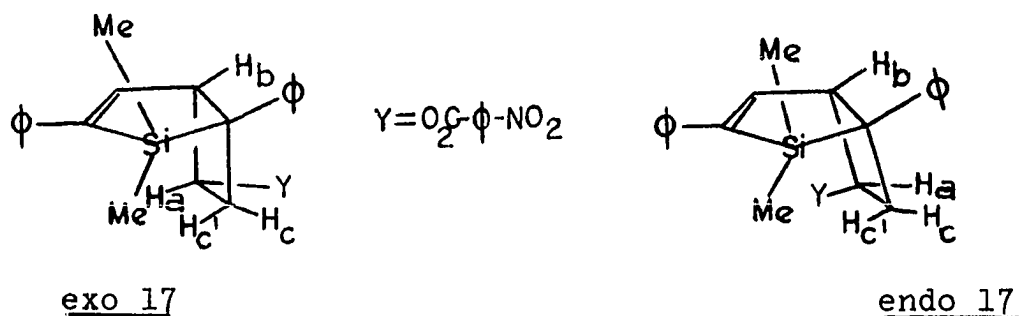

Aromatic singlet $\delta 8.08$
p-nitro benzoate
 Aromatic multiplet $\delta 7.44$
 to $\delta 6.90$, phenyls and Hx endo

doublet $\delta 6.82$ -Hx
 $\delta 5.48$ -AX₃ quartet-Ha
 $\delta 4.21$ -d of doublets-Hb

$\delta 4.86$ -d of triplets-Ha
 $\delta 3.75$ -triplet-Hb

Multiplet $\delta 3.18$ to $\delta 2.44$
 Hc and Hc' unassignable

singlets at $\delta 0.44$
 $\delta -0.14$ -silicon
 methyls

singlets at $\delta 0.50$
 $\delta -0.20$ -silicon
 methyls

The percent exo was slightly greater than the percent endo, i.e., Ha exo was greater in intensity than Ha endo. Therefore, the larger silicon methyl pair is exo.

The ring opening here and in the carbocyclic systems may both be rationalized on orbital symmetry grounds^{140,141} That is, the disrotatory ring opening of the bridging cyclobutane bond must proceed in the direction of the developing "p" orbital. Opening in this fashion of the exo isomer is prevented by the subsequent formation of the very strained trans fused cyclopropane ring¹⁴².

The discussion above also predicts the observation of no p-terphenyl from the solvolysis of 18. Participation by the carbon-carbon double bond or a silicon-carbon bond in stabilization of the formed cation must occur from exo 18. That isomer was stable to the reaction conditions employed and even stable to more polar conditions of aqueous ethanol. Anchimeric assistance by the double bond or the silicon-carbon bond in the leaving of water in the case of the protonated alcohol 16 must not occur until the cleavage of the leaving group-carbon bond is nearly complete. Participation by the bridging cyclobutane bond in the ring opening of the protonated endo alcohol 16 could have occurred but the small amount of 19 produced was discarded by chromatography. In any case the amount of p-terphenyl was small (8%) and is testament to the fact that protonation during

workup was slight. The 1,3 silicon migration postulated in scheme 3 has precedent in the literature¹⁴³. However, there the process is diradical involving the high temperature conversion of methylallyltrimethylsilane to cis and trans-crotyltrimethylsilane. Ring closure of 21, the silepin, to 22 seems unlikely in view of the isolation of 21's isomer 19. Ample precedent for the expulsion of silylene from 23 is provided in the next section.

From the above discussion scheme 1, participation of the cyclobutane bridge bond, is the correct mechanism. The difference in reaction products in comparing Goering's compound¹⁴⁴ with 18 is due to the presence of the double bond. Solvolysis of the carbocyclic system with a double bond, bicyclo[3.2.0]hept-1-ene-5-ylmesylate, gave a 50 percent yield of cycloheptatriene¹⁴⁵. No rate studies or separation and identification of the isomers were done¹⁴⁶. Observation of 20 in the solvolysis of 18 might at first appear contradictory as the rearrangement occurred in pyridine. However, it is obvious that elimination using pyridine as a base was a competing process with ring opening. Attack of the pyridine in an E₂ elimination should occur from the least sterically hindered side. Unfortunately this mode means attack occurred upon endo 18. The mechanism can be verbalized as follows. The mesylate-carbon bond started to break forming a partial positive charge at C₅. Then either

participation of the bridged bond or attack of pyridine at H_c occurred to give the products found. Solvolysis in a non-basic media should eliminate the elimination to 20.

Solvolysis of endo and exo 17, the benzoates, in 18 percent aqueous acetone at reflux for ten days did nothing as expected from the reported unreactivity of such esters. However, solvolysis in hot, 90 percent aqueous ethanol gave 40 percent yields of the silepin 19.

Photoadditions to a silacyclopentene (24)

The several attempted cycloadditions are shown below.

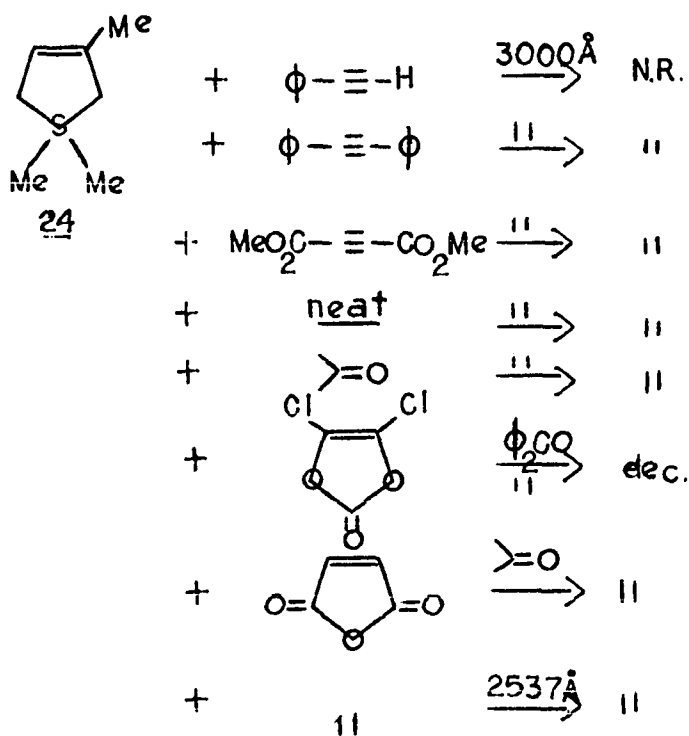

Märkl¹⁴⁷ discovered a novel route to a phosphepin derivative using initial photoaddition of dichloromaleimide to 1-phenyl-1-phosphacyclopent-3-ene-1-oxide. The sequence has been discussed on page 27. Photoadditions with other functionalizable reagents to cyclic olefins include those with vinylene carbonate¹⁴⁸, dichlorovinylene carbonate¹⁴⁹, maleic acid and anhydride¹⁵⁰⁻¹⁵⁴, bromomaleic anhydride¹⁵⁵ and 1,1-dimethoxyethylene¹⁵⁶. The substituents on these reagents make it possible to effect facile conversion of the added two carbon moiety to an olefin. Numerous 1-silacyclopent-3-ene derivatives have been reported in the literature and were cited in section 2. Steric interaction with the incoming photophile dictates choice of least substitution. Ideally this molecule would be 1,1-dimethyl-1-silacyclopent-3-ene; however, the reported synthesis gave little or no product. The compound chosen for the photoinvestigation was 1,1,3-trimethyl-1-silacyclopent-3-ene 24⁴⁸. Direct photolysis of A, 50 percent 24 in dimethylacetylene dicarboxylate, B, 50 percent 24 in phenylacetylene, C, 50 percent 24 in dichlorovinylene carbonate and D, neat 24 through Pyrex in a Rayonette photoreactor resulted in no change during the first 48 hours of photolysis. Solution D then had acetone added to it and photolysis of all four solutions was continued for another two days. Again solutions A, B, and D gave no change from the starting material in their NMR spectra. C by now

showed two silicon methyl resonances as opposed to the starting substrate's one in the NMR. Whether the additional resonance was due to decomposition or photoaddition was determined by a prep scale reaction. Photolysis of 4.8 grams 24 in 50 ml. of dichlorovinylene carbonate at 3000 Å gave no change during three days photolysis time. Addition of acetone as a sensitizer caused the gradual buildup of a new silicon methyl NMR resonance at $\delta 0.17$. After four days the reaction material was subjected to acid workup which should have cleaved the formed carbonate to a diketone. Chromatography of the resultant oil gave four fractions, two of which (1 and 4) had ketone absorptions in the IR. The first fraction, however, did not show a well defined silicon methyl region in the NMR. Instead, a very broad hump was observed characteristic of organosilicon polymers. The fourth fraction revealed the desired silicon methyl region with a very close doublet at $\delta 0.10$. The mass spectrum allayed any hope of finding a diketone. It indicated a molecular weight of 352, a far cry from the desired weight of 192. The reaction was termed unsuccessful and discarded.

The photolysis at 2537 Å of 24 in a neat solution with 1,1-dimethoxyethylene using acetophenone as a sensitizer gave no results. Addition of acetone and continued irradiation at the same wavelength still have no results. 24 was isolated almost quantitatively from the reaction mixture.

Sensitized photolysis of 24 with maleic anhydride in acetone at wavelengths greater than 3000 Å gave after basic workup a decomposition photoproduct and the dimer of maleic anhydride. The decomposition product had a very broad silicon methyl absorption in the region $\delta 0.20$ to $\delta 0.10$. The material had no definite melting point and slowly turned to oil in the region 110 to 130° C. The infrared spectrum pointed to the existence of a carbonyl in the compound but the mass spectrum provided no evidence for the diacid adduct.

Direct photoaddition of maleic anhydride to thiophene worked for Schenk; therefore, the direct approach was tried. Photolysis of a 0.6 molar solution of maleic anhydride in 24 at 2537 Å for eight hours gave two products after removal of excess 24. There was an oily solid, whose NMR showed only a broadened silicon methyl singlet at $\delta 0.30$ and a brown solid (mp. 108 to 112), which had aliphatic singlets at $\delta 1.83$ and $\delta 1.67$ and alpha keto singlets at $\delta 2.48$ and $\delta 2.42$. The mass spectrum of the brown material said the molecular weight was ca. 356. No structures will be proffered; however, the evidence points to the fact that 24 cleaved either before or after cycloaddition to give an isoprenoid unit containing ketohydrocarbon and a silicon polymer.

The results from the silacyclopentene 24 studies are nebulous at best and show reaction products which resulted from decomposition. Noted in all reactions where 24 was

destroyed is the presence of a photophile with a carbonyl, dichlorovinylene carbonate and maleic anhydride. The very strong affinity of silicon for oxygen led to attack of the carbonyl upon the silicon. This pathway could only lead to inscrutable products.

DIELS-ALDER REACTIONS OF HETEROCYCLOPENTADIENES

Another possible route to the heterocycloheptatriene ring structure is that of Prinzbach's; the thermal ring opening of a heteroquadricyclane. This method has been used to prepare oxepin and azepin derivatives and is discussed in section 2. The Diels-Alder reactions of heavily phenyl substituted silole¹⁵⁷ and germoles¹⁵⁸ has also been discussed in section 2. Since there was no problem encountered in the synthesis, the Diels-Alder reactions of the 2,5-diphenyl-heterocyclopentadienes, shown on page 109, were studied in order to affect possible conversion to the seven membered ring.

Reaction of silole 1 with an equimolar amount of maleic anhydride in refluxing benzene gave a quantitative yield of a white powder 25 (mp 180 - 181° C). The compound analyzed correctly for the addition product between maleic anhydride and 1. The NMR, shown in Figure 8b, uniquely corresponds to such an analysis with the two silicon methyl groups in different magnetic environments. There is an aromatic singlet at $\delta 7.31$ (10 H), a singlet at $\delta 6.60$ for the olefinic protons (2 H), a singlet at $\delta 4.37$ for the methine protons (2 H) and two singlets at $\delta 0.16$ (3 H) and $\delta 0.10$ (3 H) for the silicon methyls. The infrared spectrum was consistent with this assignment with its two bands at 1850 and 1770 cm^{-1} for

Diels-Alder reactions that were studied.

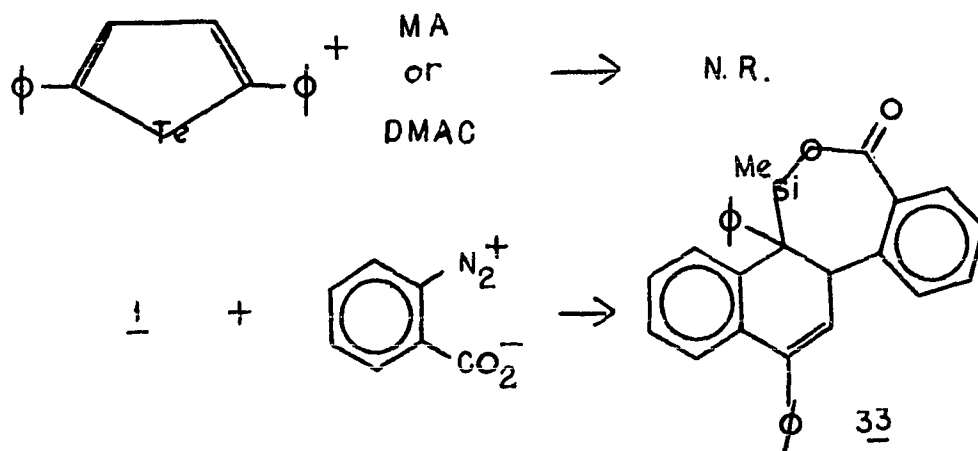
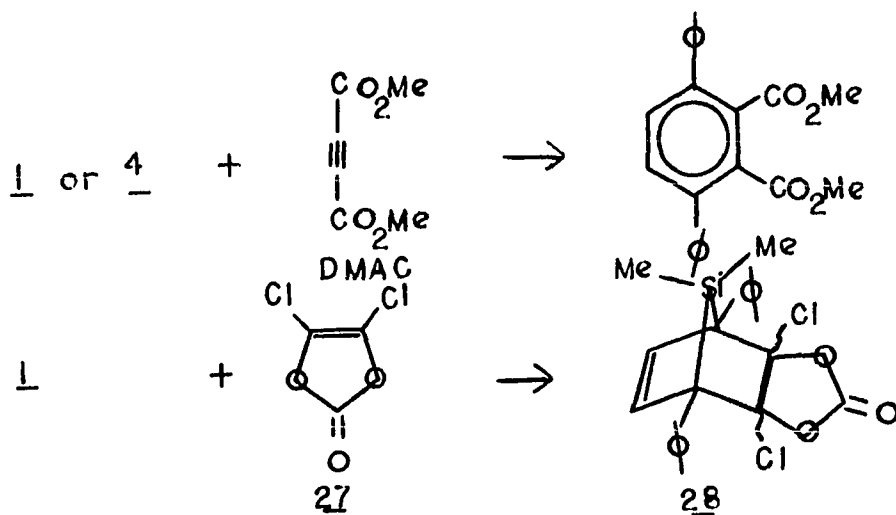
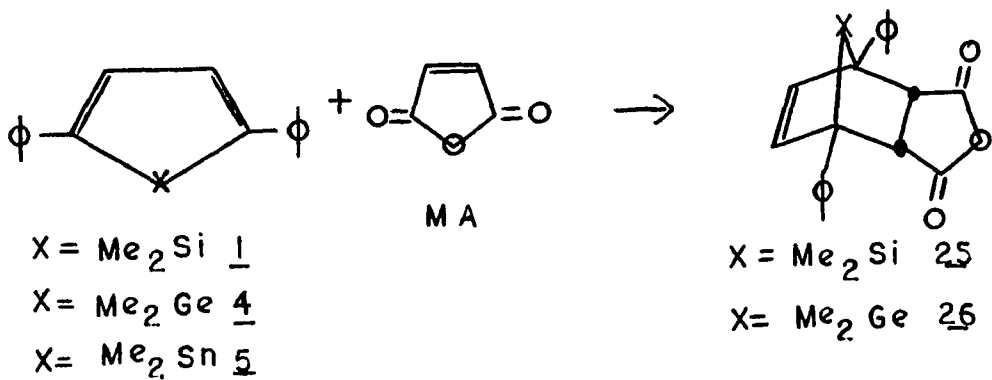

the anhydride asymmetric and symmetric stretches. Methyl esterification of the anhydride was accomplished with the Dean-Stark procedure of methanol, benzene and tosic acid. The esterification gave 95 percent yields of an off-white crystalline material (mp 179° - 180° C). The NMR and IR were decidedly different from those of the anhydride. The NMR had a pair of aromatic singlets at $\delta 7.18$ and $\delta 7.16$ (10 H), a slightly broadened olefin singlet at $\delta 6.59$ (2 H), a singlet at $\delta 4.30$ for the methine protons (2 H), and a singlet at $\delta 3.30$ (3 H) for the methyl ester protons. The methyl signals now became a singlet at $\delta 0.50$ (6 H). This signal shape might be surprising; however, it is noted that the shift difference of the anhydride methyl signals was only 0.06 ppm. The infrared spectrum is also indicative of the diester. It had only one sharp carbonyl absorption at 1740 to 1710 cm^{-1} . In fact, the progress of esterification could be followed by observing the decrease of the anhydride absorption at 1850 cm^{-1} and the concurrent increase of the ester absorption at 1720 cm^{-1} .

Reaction of maleic anhydride with 4, the germole, gave similar results. The reaction could be run in either refluxing acetone or benzene. The one with acetone is reported in the experimental to give a variant from the silole 1 reaction. When the reaction was run in benzene, the product crystallized as the solution was cooled and needed

to be recrystallized only once for an analytical sample 26 (mp 179° - 181° C). The NMR line shape was the same as that of 25 and is written in the Experimental. The mass spectrum was consistent with the structure assignment showing the proper isotope ratio for germanium in the molecular ion region of (m/e) 404 to 408. The IR was typical of five membered ring anhydrides with the carbonyl absorptions at 1860 and 1780 cm^{-1} .

The reaction of maleic anhydride with 5 gave a 40 percent yield of an off-white powder (mp 258° - 260° C) when run in refluxing benzene. The sample melted with the concomitant evolution of gas. The residue did not melt in the same place. This observation was at odds with the melting phenomena of the other two adducts. They solidified and melted again at the same point. The mass spectrum indicated a 1:1 adduct had been formed. The molecular ion region reflected the isotope abundance of tin. However, the IR showed no carbonyl. Instead, there was a very broad, strong absorption at 1600 cm^{-1} . The NMR was unable to be taken in deuteriochloroform, d_6 -acetone or d_6 -benzene due to the extreme insolubility of the material. No further work was done on this compound.

The Diels-Alder reaction of 1 and 4 with dimethylacetylene dicarboxylate produced different results from those of Gilman¹⁵⁷, but similar to those of Zuckerman¹⁵⁸ were explosion of dimethyl germylene occurred at 50°C to give the

tetraphenyl phthalate ester. Reaction of either 1 or 4 at room temperature with dimethyl acetylene dicarboxylate in ether solvent gave dark red solutions after about 15 minutes. Heating the solutions caused quicker darkening. Isolation of the solid material which fell out of solution with cooling gave good yields of 1,4-diphenyl-2,3-phthalate dimethylester. This facile cleavage as compared to Gilman's and Zuckerman's adducts, which were isolable, might be rationalized on basis of radical stabilization by the bridgehead phenyls. In the tetraphenyl case, steric interaction between the bridgehead and olefin phenyls would not allow the plane of the bridgehead phenyl to be perpendicular to the carbon-silicon bond. There is no such interaction in the diphenyl adduct; therefore, the bridgehead phenyl plane can become perpendicular to the carbon-silicon bond thus stabilizing diradical cleavage of that bond by resonance. Witlak and Barton¹⁵⁹ have isolated the hexafluoro-2-butyne Diels-Alder adduct with 1. Steric interaction between the bridgehead phenyls and the olefin perfluormethyl group is quite small and may permit perpendicularity of the bridgehead phenyls. The resonance stabilization argument is brought in to some question by this result.

An interesting rearrangement is provided by the Diels-Alder reaction of 1 with dichlorovinylene carbonate 27. Carbonate 27 has been added photochemically to ethylene and

thermally to anthracene and cyclopentadiene¹⁴⁹. Conversion of the formed carbonate of such reactions to the diketone followed by reduction to the diol gives entry to the elegant series of reactions by Corey¹⁶⁰ for the conversion of a diol to a cis olefin.

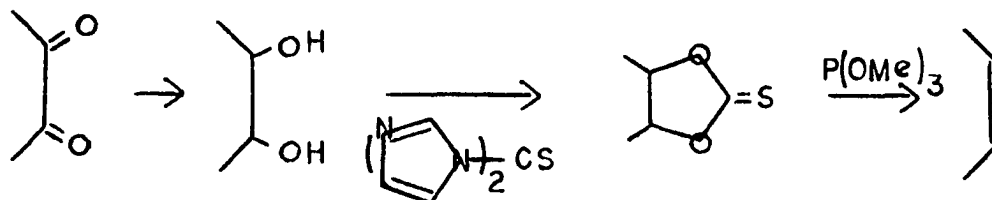

The addition of silole 1 and 27 was tried in refluxing benzene and then refluxing toluene with no results. Only starting material was isolated. When a sealed tube of 1 and excess 27 was heated to 155° C and above for twelve hours, a reaction occurred to give a solid residue having a silicon methyl singlet at 0.25 in the NMR spectrum. The resonance did not result from silole 1; therefore, the sample was chromatographed to give 1,4-diphenyl-2-chloro-3-hydroxybenzene, mp 142° - 143°C. This surprising result, the dihydroxy compound was expected, led to a reinvestigation at lower temperature. Heating 1 in excess 27 in an open flask held below 150° C produced an oil after the excess 27 was removed. The oil was crystallized from methylene chloride to give very large cubes of 28 which explosively

decomposed at 153° C. The carbon, hydrogen analysis was correct for the Diels-Alder adduct. Accurate silicon, oxygen and chlorine analysis could not be obtained because of the interference of silicon in the analysis procedure. The NMR is characteristic of Diels-Alder adducts to 1 with an aromatic singlet at δ 7.32 (10 H), and olefin singlet at δ 6.42 (2 H), and two silicon methyl singlets at δ 1.01 and δ 0.49 (3 H apiece). It is shown in Figure 13b. The IR showed typical carbonate absorptions at 1860 to 1810 cm^{-1} . The mass spectrum did not show a parent ion at 416. Instead there was a loss of chlorine to give the characteristic doublet peaks at 383 and 381 in a 1 to 3 ratio. The triplet at (m/e) 376, 374, 372 corresponded to loss of 44 (CO_2) from the parent ion. There was a metastable at 343 to 341 corresponding to a loss of chlorine from the M- CO_2 peak at (m/e) 372.

The violent decomposition point was the next object of interest and was investigated under the assumption that a gas was being given off. As the adduct 28 was slowly warmed in a vacuum, nothing happened until 153° C. Then decomposition occurred explosively to give a green glass. The gas collection bulb was checked and was found not to have increased in weight. No gas had been evolved. An NMR, shown in Figure 13a, of the green glass shows it to be composed of about 30 percent starting material 28. The rest

Figure 13a. 60 MHz NMR spectrum of adduct 28 and the decomposition intermediate

Figure 13b. 60 MHz NMR spectrum of 28, the silole-dichlorovinylene carbonate adduct

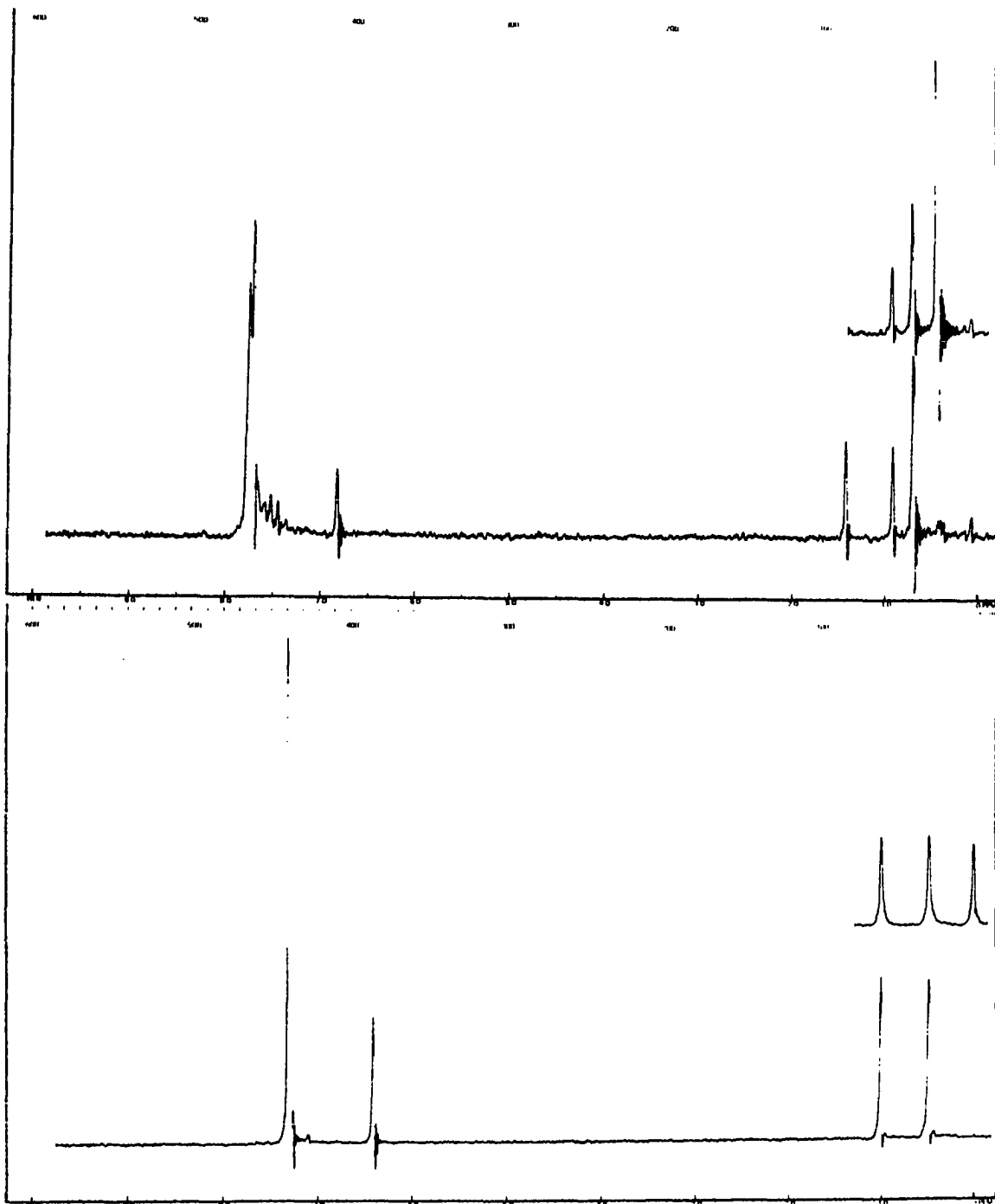

of 28 had cleanly decomposed to a compound with a silicon methyl singlet at $\delta 0.23$, the same chemical shift from the sealed tube residue before chromatography. The IR showed carbonate and carbonyl absorptions at 1840 and 1760 cm^{-1} plus an unexplainable sharp absorption at 2120 cm^{-1} . A high temperature NMR study in a sealed tube with tetrachloroethylene as a solvent proved decomposition occurred only above 150° C. Chromatography on silica gel of the resultant intermediate from the high temperature NMR experiment gave 1,4-diphenyl-2-chloro-3-hydroxybenzene. The NMR evidence dictates the silicon methyls of the intermediate must be equivalent. The most reasonable species is one where free rotation of the carbon-silicon bonds is allowed. A possible structure for this intermediate is that resulting from β -halogen-silicon elimination. β cleavage is well documented¹⁶¹ occurring either from cis or trans configurations. It might be expected, but there is no reason why a second elimination should not occur from such a chloro-silicon intermediate A. A better structure does not arise from β -halogen elimination; rather from initial oxygen attack on the silicon. β elimination from the intermediate B gives C which should be thermally stable. Hydrolysis of C by the silica gel column would give the chlorophenol product found.

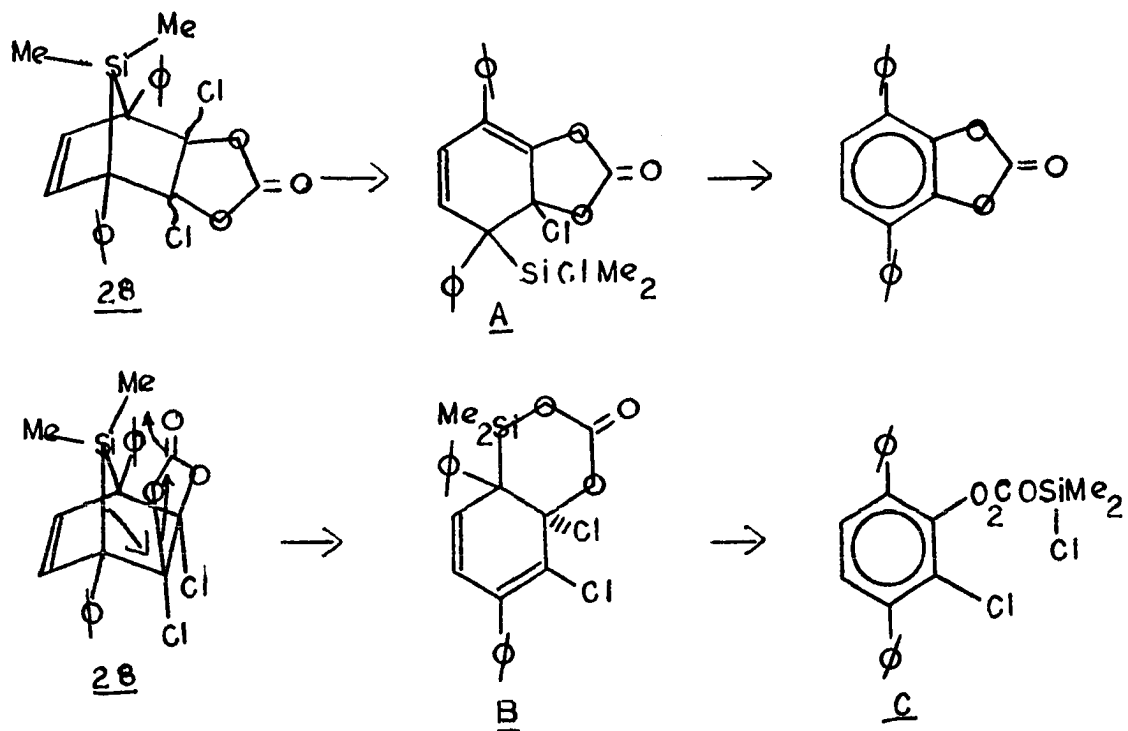

The photochemical rearrangement of the 7-oxanorboradiene derivative has already been cited. Since the 7-silano-7-oxanorbornadiene derivatives were found to be unstable, it was decided to investigate the benzo derivative. The benzo group should, it was felt, provide added stability to the 7-silano-7-oxanorbornadiene. To this end the synthesis of 2,3-benzo-7,7-dimethyl-1,4-diphenyl-7-silano-7-oxanorbornadiene 29 from 1,1-dimethyl-2,5-diphenylsilole 1 and benzyne was undertaken. No particular difficulties were foreseen, as

a similar addition between benzyne and 1,1-dimethyl-2,3,4,5-tetraphenyl-1-silole had been reported¹⁵⁷ to proceed in yields up to 60 percent. When an equimolar solution of the hydrochloride salt of benzenediazonium-2-carboxylate, propylene oxide (to remove the hydrogen chloride)¹⁶², and 1 were refluxed in 1,2-dichloroethane, most of the silacyclopentadiene was recovered unreacted, along with a small amount of a colorless adduct. Use of a three-fold molar excess of the benzyne precursor afforded, after chromatography on silica gel, a 77 percent yield of the same colorless, crystalline solid, mp 278 - 279°, as the sole insoluble product derived from the silole 1. This material was tentatively assigned structure 30 on the basis of its NMR spectrum [δ 7.77 - 6.82 complex aromatic multiplet (18 H), δ 5.78 methine doublet ($J = 6.8$ Hz) (1 H), δ 4.82 methine doublet ($J = 6.8$ Hz) (1 H), 0.10 methyl singlet (3 H) and δ -0.33 methyl singlet (3 H)]; infrared spectrum [1729 cm^{-1} (lactone carbonyl), 1327 cm^{-1} (lactone C-O stretch)]; mass spectrum (base and parent peak 458 m/e) and satisfactory elemental analysis. The striking upfield position of one of the methyl groups strongly supported the assignment of a structure such as 30, as this effect would be expected for the methyl syn to the benzo group and, consequently, in the shielding cone.

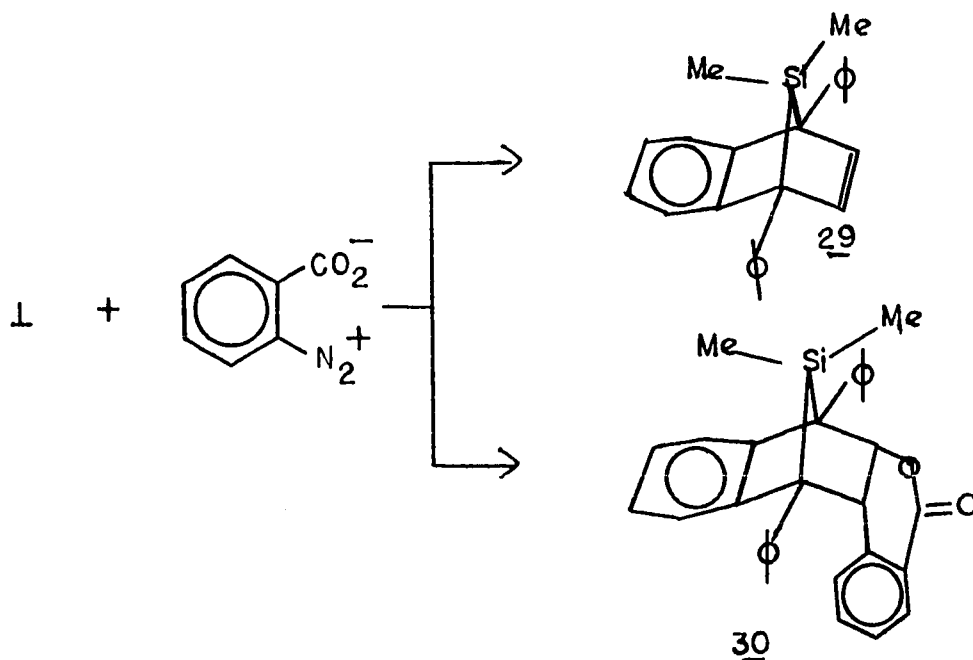

A plausible mechanistic scheme to account for the formation of 30 involves the initial loss of nitrogen to form the 1,4-dipole 31, attack on 29 at the double bond and carbon-oxygen ring closure.

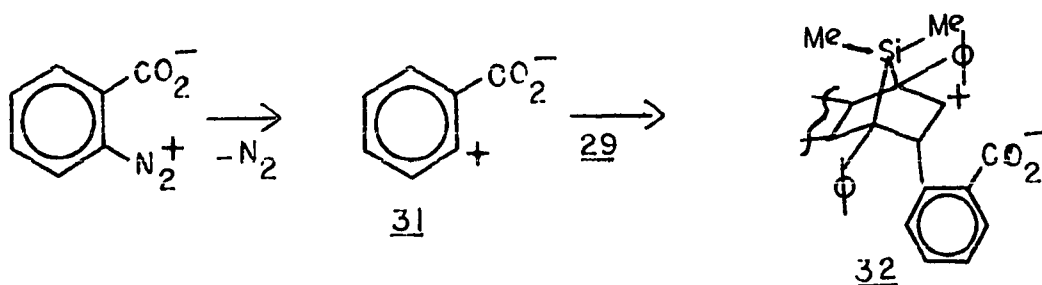

However, there were certain disturbing points with regard to the structural assignment of 30. This addition would represent the only example of the trapping of intermediate 31 by a simple olefinic system. Current evidence has characterized the 1,4-dipolar cycloaddition¹⁶³ as a two-step process proceeding through a zwitterionic intermediate such as 32. However, it has been generalized that only dipolarophiles possessing strong nucleophilic or electrophilic reactivity will combine with 1,4-dipoles^{163,164}. It would be quite difficult to rationalize these observations with the formation of 30 as no pronounced reactivity of this type would be expected from either 29 or 1. Secondly, there was no loss of CO₂ from the parent ion observed in the mass spectrum, as would be expected from 30. Consequently, it was deemed necessary to determine the structure of the reaction product by X-ray diffraction techniques.

Single crystals of the adduct from 1 and benzenediazonium-2-carboxylate suitable for X-ray analysis were grown from diisopropyl ether. Experimental details may be found in Ref. 165. The X-ray model is given in Figure 14. A computer drawing of the final seven-membered ring containing silicon and oxygen (atoms 1-7) is in a boat conformation. The silicon atom is tetrahedrally coordinated and the four atom fragments of the carboxyl group (O(2), C(3), C(4) and O(10)) and C(3), C(4), C(5) and C(6) are all planar. C(6)

Figure 14. Crystal structure of siloxapinone 33

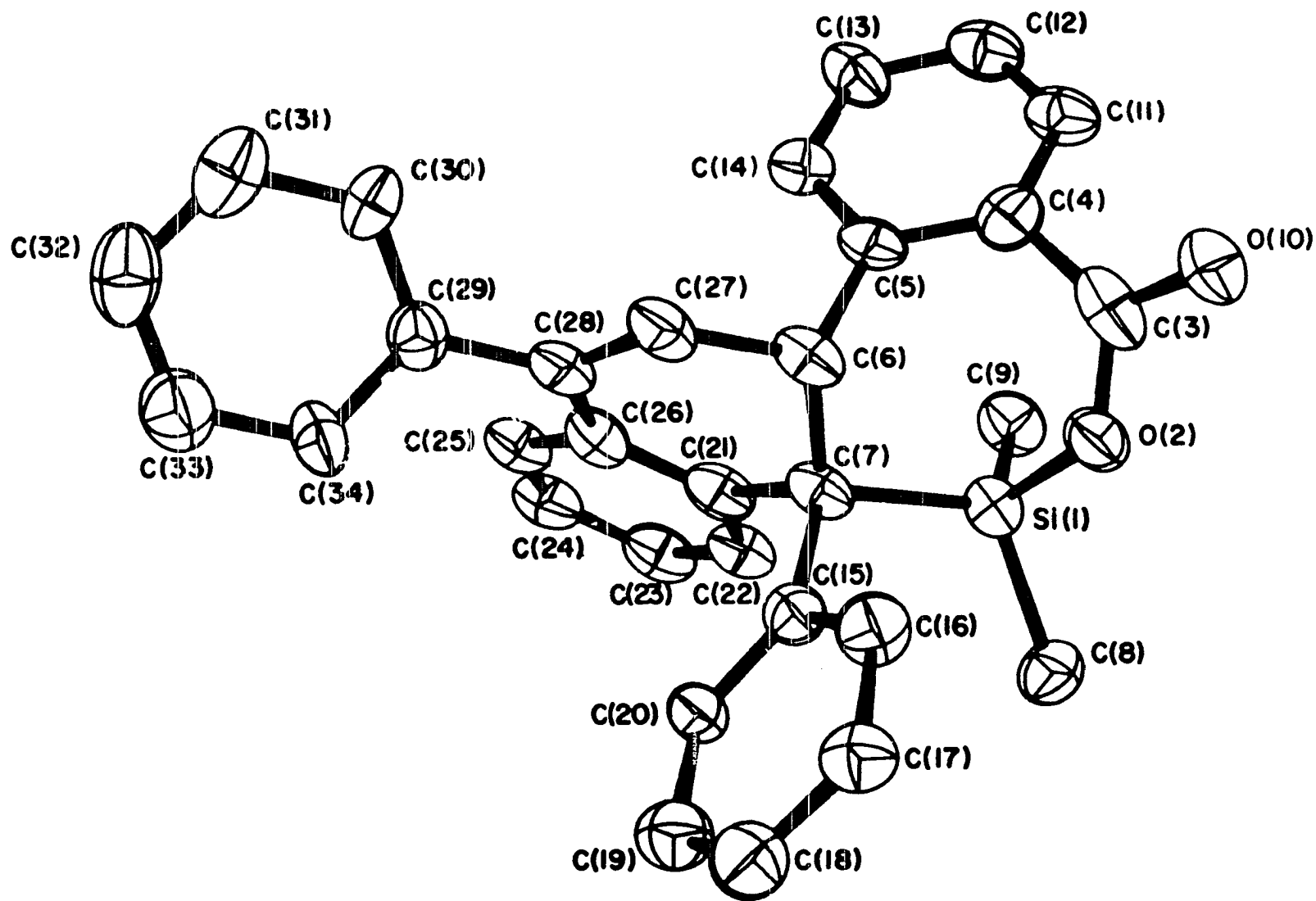

and C(7) are tetrahedral. The bond distances to C(7) all seem slightly long. The six-membered ring (C(6), C(21), C(26), C(28) and C(27)) is fused to the seven-membered heterocyclic ring in a cis diequatorial manner. The hydrogen of C(6) is axial as is the phenyl ring (C(15) through C(20)). The conformation about the double bond (C(27) - C(28)) is cis. All four phenyl rings are planar within experimental error.

The adduct resulting from 1 and benzenediazonium-2-carboxylate then does not possess structure 30 but is the siloxapinone 33.

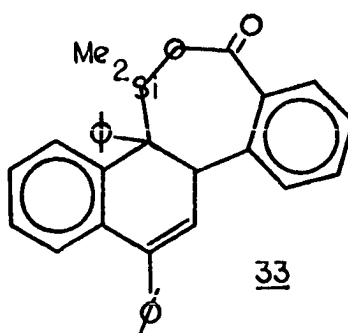

While it has been known for the last decade that benzenediazonium-2-carboxylate will thermally decompose to benzyne^{166,167,168}, the detailed mechanism of this decomposition has not been fully elucidated. Three possibilities must be considered: (a) concerted loss of carbon dioxide

and nitrogen, (b) loss of nitrogen to afford the dipolar species 31 followed by loss of carbon dioxide or attack on some trapping agent before loss of carbon dioxide, and (c) initial loss of carbon dioxide to provide 34 which may either lose nitrogen or react directly with the trapping molecule.

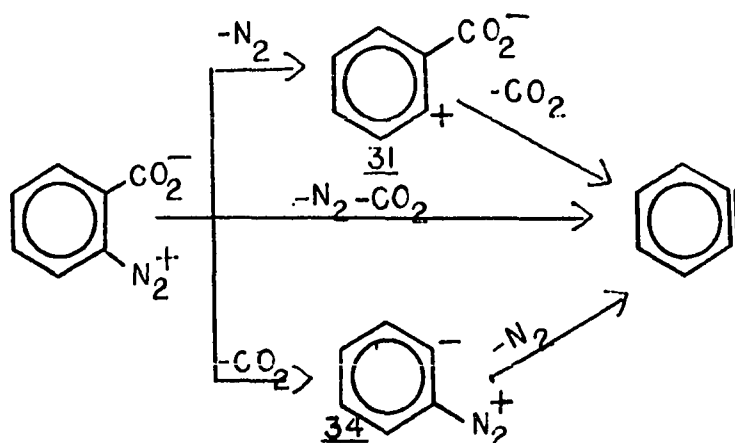

Intermediate 34 has never been seriously implicated in this decomposition, but 31 has several times been suggested as a possible intermediate. Both Knorr¹⁶⁹ and Yaroslavsky¹⁷⁰ have isolated phthalimides from the reaction of isocyanides

with benzenediazonium-2-carboxylate, and 31 has been postulated as the reactive intermediate which adds across the carbon-nitrogen multiple bond. The formation of phthalic anhydride from the reaction of nickel tetracarbonyl and benzenediazonium-2-carboxylate may also proceed through 31¹⁶⁹. A search of the literature reveals that the only situation where 31, although generated from the pyrolysis of diphenyliodonium-2-carboxylate¹⁷¹ or potassium 2-halobenzoates¹⁷², might be involved in an addition to a carbon-carbon multiple bond is in the reaction with benzyne itself to produce 3,4-benzocoumarins and xanthenes. In each of these cases, the products could also be explained by a series of substitution reactions with the highly reactive benzyne molecule attacking the benzenediazonium-2-carboxylate. It is also interesting to note that, while benzocoumarin arises from pyrolysis of diphenyliodonium-2-carboxylate¹⁷¹ or 2-halobenzoates¹⁷², this product has never been observed during the decomposition of benzenediazonium-2-carboxylate¹⁷³.

In view of the above proposals for the mechanism of thermal decomposition of benzenediazonium-2-carboxylate, it appeared that a logical mechanism for the formation of 33 would involve attack on the olefinic bond of 29 by 31, to generate 32 followed by carboxylate anion attack upon

the silicon atom. Given this mechanism it is apparent from

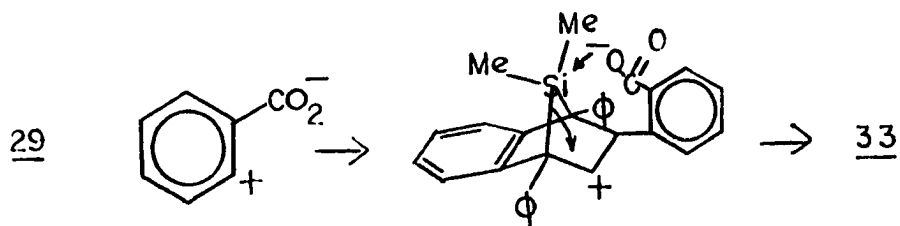

the stereochemistry of 9 that attack by the phenyl cation must be exo, as only this mode would result in the proper orientation for carboxylate attack upon the silicon atom. It would, of course, be possible for the reaction to proceed in a concerted fashion. However, the absence of rearranged products could only argue against a discrete intermediate such as 32 if the relative rates for the Wagner-Meerwein shift and the process 32 \rightarrow 33 were known. At any rate the isolation of the unique adduct 33 by a process which the similar reaction between cyclopentadiene and benzyne generated from benzenediazonium-2-carboxylate fails to employ¹⁷⁴, appears to indicate that a definite driving force must be the formation of the silicon-oxygen bond which is well established to be far stronger than the carbon-oxygen bond, cf., 112 kcal/mole, Si-O; 85.5 kcal/mole, C-O.

Upon consideration of the fact that the mechanism presented above for the formation of 33 does not depend upon the silicon-oxygen bond formation for a driving force, it was decided to put that point to a test. The intermediate strength of a germanium-oxygen bond¹⁷⁵ compared with the carbon-oxygen and silicon-oxygen bonds made the prospect of performing this reaction with a system where silicon had been replaced by germanium especially intriguing.

If indeed the germanium-oxygen bond was of significantly lower strength than the silicon-oxygen bond, and if the thermodynamics of this bond formation were really the controlling factor in the trapping of 31, we might expect not to obtain any products resulting from addition of 31. However, when the reaction between benzenediazonium-2-carboxylate and 1,1-dimethyl-2,5-diphenylgermole 4 was run under exactly the same conditions as for 1, a single isolable product was obtained whose spectra and elemental analysis corresponded to 35. The NMR spectrum of 35 was virtually identical with that of 33 [δ ca. 7.75 - 7.1 complex aromatic multiplet (18 H), δ 5.85 olefin doublet ($J = 6.8$ Hz) (1 H), δ 4.84 methine doublet ($J = 6.8$ Hz), δ 0.33 methyl singlet (3 H) and δ -0.12 methyl singlet (3 H)]. The mass spectrum showed a strong parent ion and a very

small fragment ion resulting from loss of carbon dioxide, in keeping with structure 35.

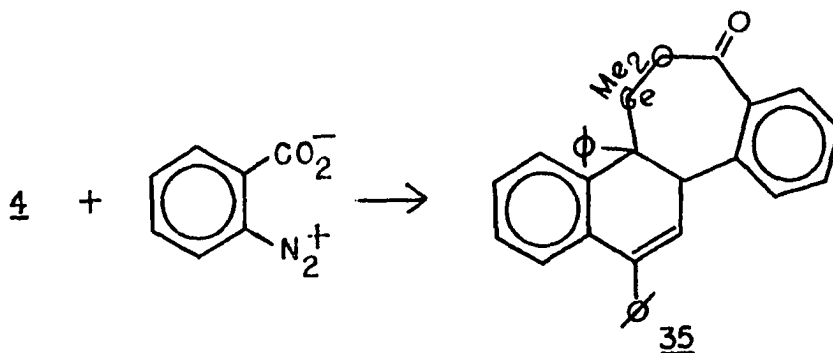

While mechanistic use of the 1,4-dipole 31 was extremely convenient, it was recognized that the isolation of the unique adducts 33 and 35 in no way necessitated the existence or intervention of this intermediate. Indeed the very inability of this mechanism to account for the driving force derived from silicon- or germanium-oxygen bond formation appeared to argue against its operation. Therefore, in order to determine whether the 7-silanorbornadiene 29 was reacting directly with benzenediazonium-2-carboxylate or with some intermediate (e.g., 31) derived from benzenediazonium-2-carboxylate it would be desirable to prepare 29 and attempt

to react it with benzenediazonium-2-carboxylate under conditions where the inner salt does not decompose. To achieve this purpose the method of benzyne generation chosen was the lead tetraacetate oxidation of 1-aminobenzotriazole 36¹⁷⁶. However, reaction of the silole 1 with benzyne generated in this fashion yielded only 1,4-diphenyl-naphthalene 37 upon normal workup. While this represents a drastic difference in thermal stability between 29 and the tetraphenyl adduct reported by Gilman¹⁷⁷, it has been noted previously that the Diels-Alder adducts of 1 and acetylenes were far less stable than the analogous adducts resulting from 1,1-dimethyl-2,3,4,5-tetraphenylsilole.

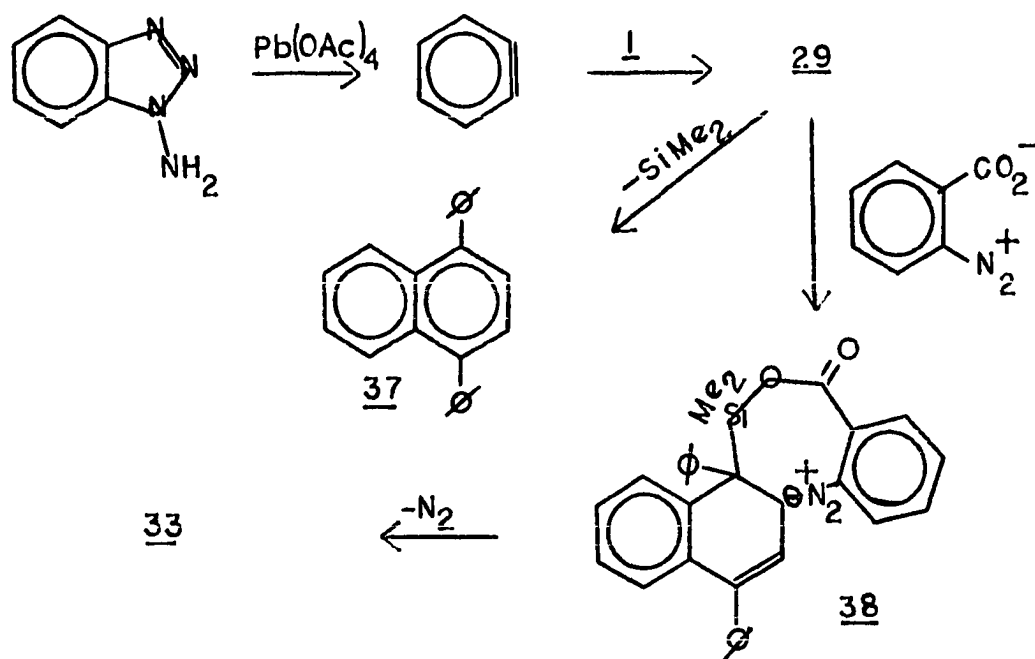
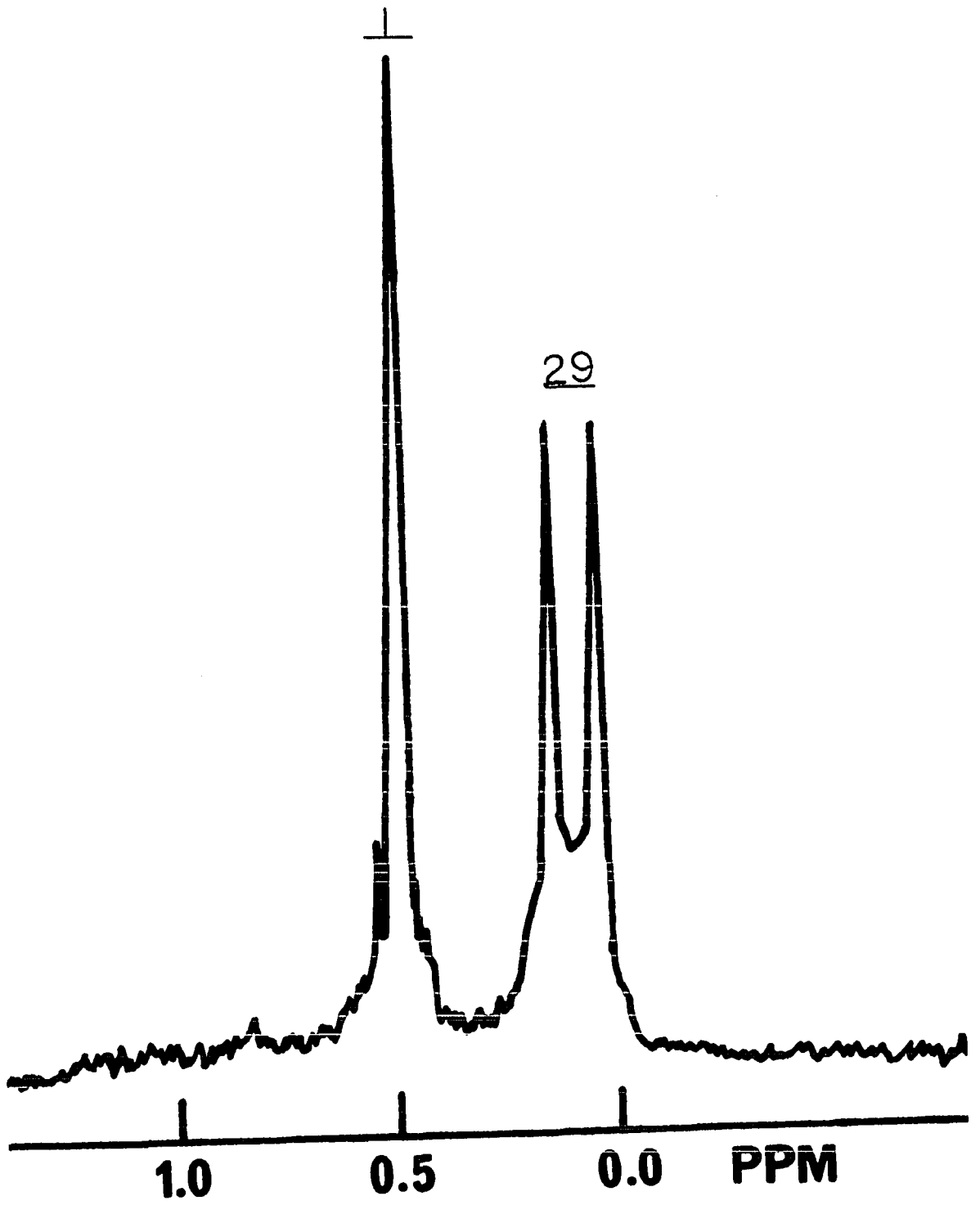
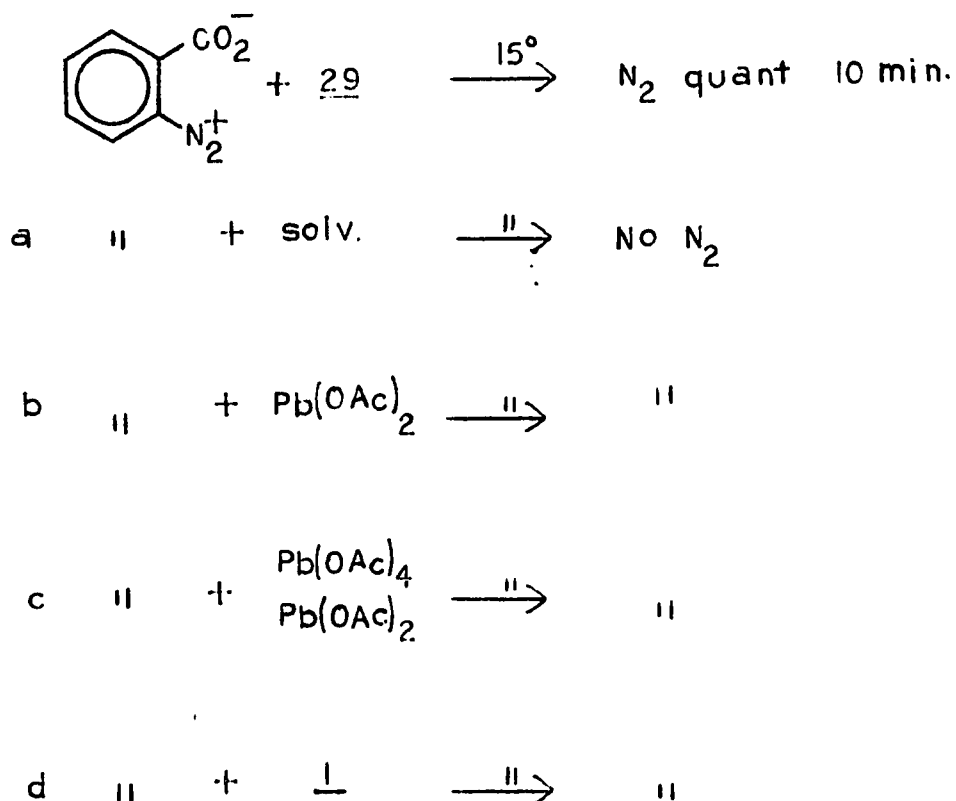

Figure 15. 60 MHz NMR spectrum of a mixture of 29 and 1
at ca. -50° C



When the reaction of 1 and benzyne, generated from 1-aminobenzotriazole, was performed at -78°C and the reaction mixture examined by NMR (at ca. -50°C), it was revealed that ca. one-half of the silole 1 was consumed and two new singlets of equal intensity appeared slightly upfield, therefore, presumably corresponding to the two methyl groups in 29 (Figure 15). After establishing that the relative concentrations of 29 and 1 did not noticeably change after several hours at -50°C , a slight excess of benzenediazonium-2-carboxylate was added to the reaction mixture and the mixture was allowed to stand at 0°C overnight. Workup of the reaction afforded both 37 and 33 in ca. a 2 to 1 ratio. As the solubility of benzenediazonium-2-carboxylate in the solvent used, dichloromethane, was probably not high at these temperatures, it is likely that there is an insufficient amount of this reagent to react with 29 before the thermal decomposition of 29 to 38. The key point is that 29 apparently reacts with benzenediazonium-2-carboxylate to form the siloxapinone 33 at temperatures where benzenediazonium-2-carboxylate is quite stable. Possibly more conclusive evidence that 33 arose solely from reaction between 29 and benzenediazonium-2-carboxylate comes from experiments where 29 was first formed from 1 and the benzotriazole 36 at low temperatures, benzenediazonium-2-carboxylate was added and the reaction mixture allowed to warm to slightly below room temperature. After only ten

minutes at 20° gas evolution from this sample was essentially quantitative for loss of only nitrogen. At the same time and under identical thermal conditions, solutions containing



benzenediazonium-2-carboxylate and (a) only solvent (dichloroethane), (b) lead diacetate, (c) lead tetraacetate and lead diacetate, (d) silole 1 evolved either no gas or only a very small fraction of the amount obtained from the sample

containing preformed 29. Therefore, it can be conclusively stated that 33 is the result of reaction between 29 and benzenediazonium-2-carboxylate with no involvement of any intermediate derived from prior decomposition of the benzenediazonium-2-carboxylate.

After attack of 29 by the carboxylate anion of benzenediazonium-2-carboxylate the intimate details of this reaction aren't known. Several courses are available: (a) formation of a pentavalent silicon anion 39 which may either go directly to 33 or collapse to the allylic anion 37; (b) proceed directly by carbon displacement to 38 followed either by nitrogen loss to 40 and then final bond formation to give 33 or displacement of nitrogen by the anionic portion to provide 33 directly; or (c) an essentially concerted process leading to 33.

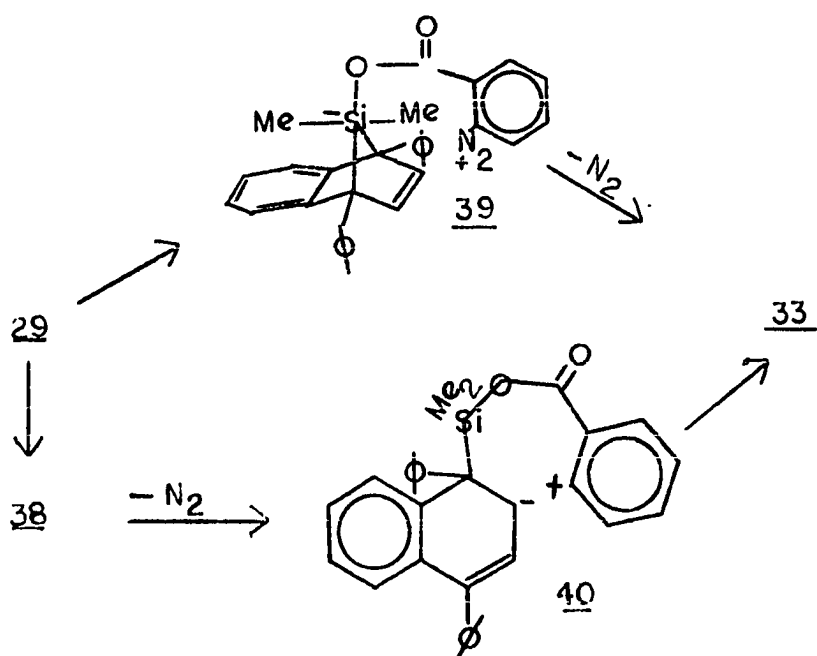

The discovery of a high-yield reaction with benzenediazonium-2-carboxylate which could easily have been explained in mechanistic terms involving the intermediate 31, but instead, has been shown to involve only benzenediazonium-2-carboxylate itself casts serious doubt upon the evidence which has been offered for the existence of 31 in the thermal decomposition of this useful benzyne precursor. However, it should be noted that this work has no bearing upon the mechanism of benzyne formation from benzenediazonium-2-carboxylate since the reaction of 29 \rightarrow 33 and the corresponding reaction leading to 35 do not involve decomposed benzenediazonium carboxylate. The study has accidentally hit upon an optimum system for this type reaction which depends not only on the presence of a bridged silicon or germanium, but also on the particular substitution of the bicyclic system. As mentioned previously¹⁷⁷, 1,1-dimethyl-2,3,4,5-tetra-phenylsilole did not undergo this reaction -- presumably for steric reasons. The same is true for 1,1,2,3,4,5-hexa-phenylsilole¹⁷⁷ which was confirmed by attempting to react the Diels-Alder adduct of 1,1,2,3,4,5-hexaphenyl-1-silacyclopentadiene and benzyne with benzenediazonium-2-carboxylate. No reaction took place. The maleic anhydride adduct of 1, 25, gave no isolable products resulting either from the addition of benzyne or benzenediazonium-2-carboxylate; indeed the reaction of 25 and benzenediazonium-2-carboxylate

afforded reasonable yields of 1,4-diphenylphthalic anhydride under conditions where 25 is quite stable alone.

RING CLOSURE USING SULFUR DICHLORIDE

The previous parts of this thesis have dealt with the formation of Group IV heterocycloheptatrienes or attempts thereof exclusively. However, the interest of the thiepin ring system as an unstable configuration has also intrigued many chemists. Its synthesis, unlike that of the oxepin and azepin, has proved illusive. It was in a slightly different modus operandi that the next series of reactions was investigated. Since one's method of thinking about a compound must change when that compound's heteroatom changes from Group IV to Group VI, synthesis of thiepins provided a sometimes happy diversion from the silicon chemistry presented.

A particularly successful method for the synthesis of monoheterocyclopentadienes 41 is the addition of RMH_2 ($\text{M} = \text{P}^{178}, \text{As}^{179}, \text{N}^{180,181}$), and MH_2 ($\text{M} = \text{S}^{182-184}, \text{Se}^{185}, \text{Te}^{186}$) to 1,3-diyne. An attractive extrapolation of this route to the synthesis of heterocycloheptatrienes would involve the addition of RMH_2 or MH_2 to 3-en-1,5-diyne. This route has been investigated with H_2S and the readily available *o*-bis(phenylethynyl)benzene¹⁸⁷ 42 in hopes of preparing 2,4-diphenylbenzo[d]thiepin 43 in a convenient one-step synthesis. This reaction was originally planned as a model for the unknown selenepin and tellurepin ring systems. However, considerable effort has failed to bring

about the desired conversion of 42 \rightarrow 43 as 42 is quite inert to the addition of hydrogen sulfide.

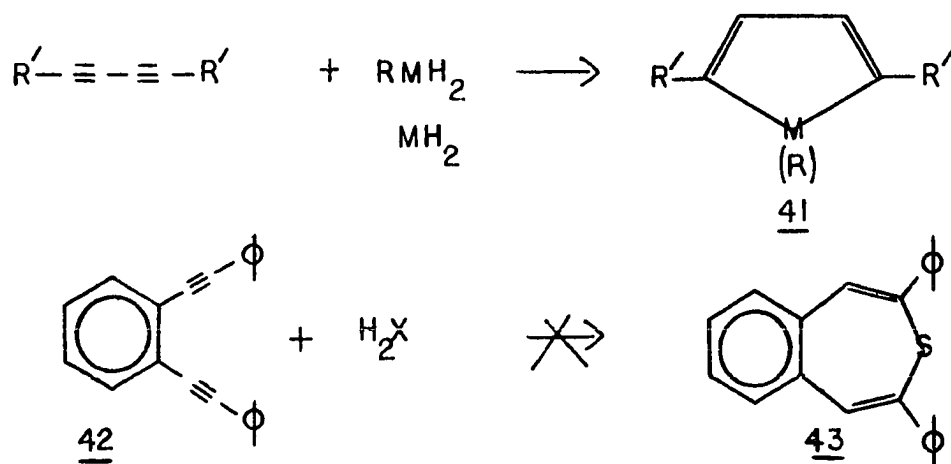

Another possible one-step route to a benzo[d]thiepin from 42 can be envisioned from the addition of sulfur dichloride. The addition of sulfur dichloride to acetylenes is known to proceed through an often isolable vinyl sulfonyl chloride 44¹⁸⁸ which can add to another molecule of acetylene to afford a β,β' -dichlorodivinyl sulfide 45¹⁸⁹. It has also been shown that SCl_2 will add to 1,3-diynes to yield 3,4-dichlorothiophenes¹⁹⁰. It was therefore hoped

that the conversion of 42 \rightarrow 46 could be easily effected.

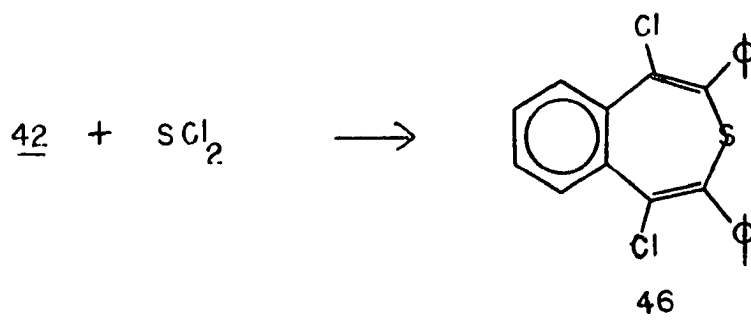

Since SCl_2 is an electrophilic reagent, whose reactions with acetylenes are thought to proceed through a thiirene type intermediate which suffers nucleophilic attack by chloride anion¹⁸⁸, the known behavior of 42 with electrophiles must be considered before predicting the course of this reaction. Whitlock¹⁸⁷ has reported that electrophilic attack on 42 results in formation of diphenylbenzofulvenes, or ring systems derived therefrom, without exception. This system, of course, results from interaction of the triple bonds in the addition step. However, since it is questionable how much of the positive charge in the intermediate derived from SCl_2 addition to an acetylene resides on carbon, prediction could not be made for a similar course with SCl_2 .

Several routes by which SCl_2 might react with 42 may be mechanistically envisioned and a choice between them is

difficult. It was assumed that a mixture of products would likely result and hoped that 46 would represent a significant fraction of this mixture. Neither of these things turned out to be the case. Addition of SCl_2 to 42 provides a 90 percent yield of one product which analyzed for 46 less the elements of hydrogen chloride. The most striking feature of this orange, crystalline material is its NMR spectrum, shown in Figure 16, which consists solely of two gross multiplets in the aromatic region ($\delta 8.5-8.3$, $7.5-6.3$; 12 H) and two peaks in the olefinic region ($\delta 5.6$, 5.45 ; 1 H) which are actually multiplets upon high resolution. The loss of HCl is easily rationalized when one considers the known reaction of SCl_2 and diphenylacetylene to give 3-chloro-2-phenylbenzo[b]thiophene 47¹⁸⁸.

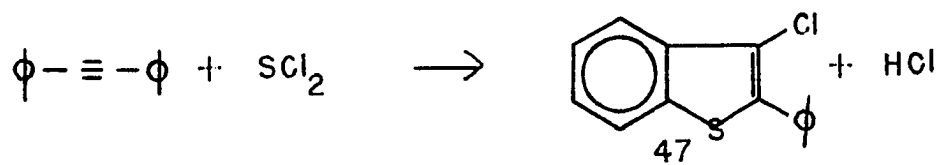

Reasonable structures which can be drawn for the molecular formula, $\text{C}_{22}\text{H}_{13}\text{SCl}$, solely on mechanistic considerations are shown in Figure 16 (48, 49 and 50). However, examination of models of these three molecules makes a choice of 50 very easy on the basis of the NMR spectrum. Regardless of the stereochemistry of the exocyclic chloro-benzylidene unit either H_A or H_B is pushed into the

Figure 16. 60 MHz NMR spectrum of $C_{22}H_{13}SCl$

Structure 48

Structure 49

Structure 50

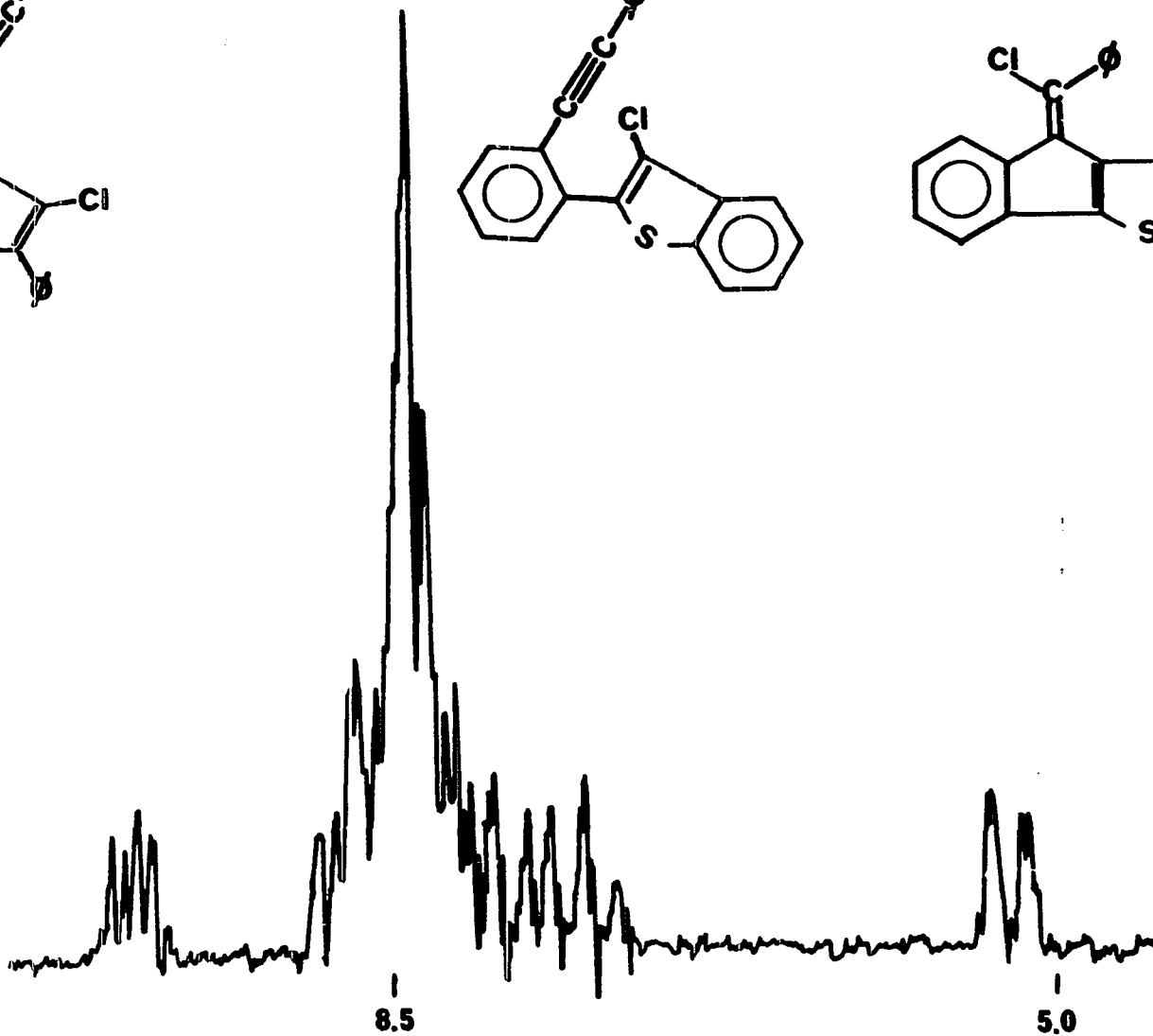
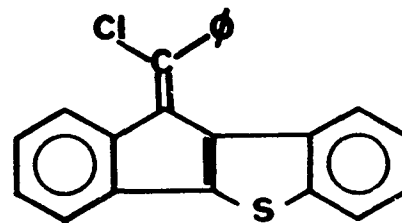
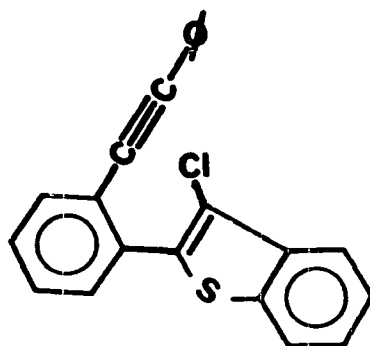
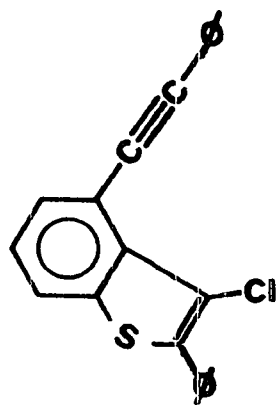

shielding cone of the phenyl ring thus explaining the prominent upfield shift of a single proton. Rotation of this phenyl ring is prevented by H_A or H_B .

A rational mechanism for the formation of 50 involves electrophilic attack of SCl_2 on one acetylenic linkage of 42 with concomitant involvement of the other triple bond as postulated by Whitlock¹⁸⁷ for the addition of bromine and hydrogen bromide. The intermediate sulfenyl chloride could then attack a phenyl ring to afford 50.

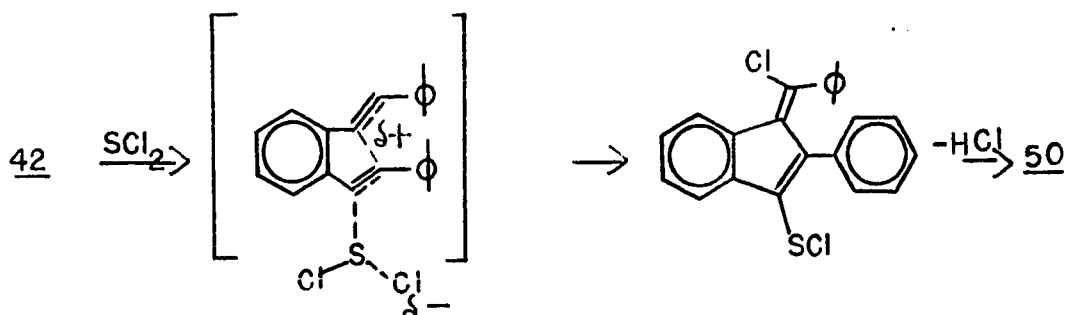

As 50 represents the first example of the benz[b]-indeno[2,1-d]thiophene ring system¹⁹¹, conversion of it into the parent system is an interesting possibility. This conversion was easily accomplished by treatment of 50 with potassium hydroxide in hot triethylene glycol. This procedure affords 10H-benz[b]indeno[2,1-d]thiophene 52 in ca. 50 percent yield. The conversion may be viewed as proceeding through initial attack by hydroxide ion on the

exocyclic double bond so as to yield the indenyl anion 51 followed by several straightforward steps ending with a reverse condensation. The title compound 52 can be easily converted into the 10-acid 53 through treatment with *n*-butyl lithium and then CO_2 .

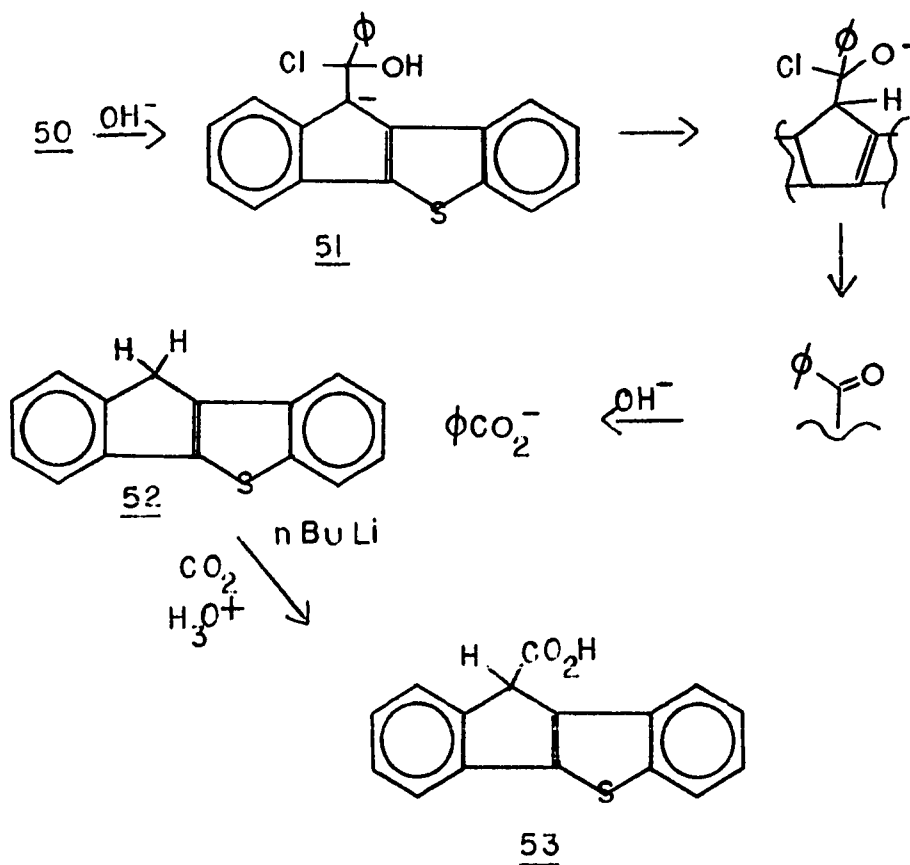

Final, conclusive proof of 52 was obtained by X-ray crystallography. The molecular structure of 52 is shown in Figure 17.

Figure 17. Crystal structure of adduct 50

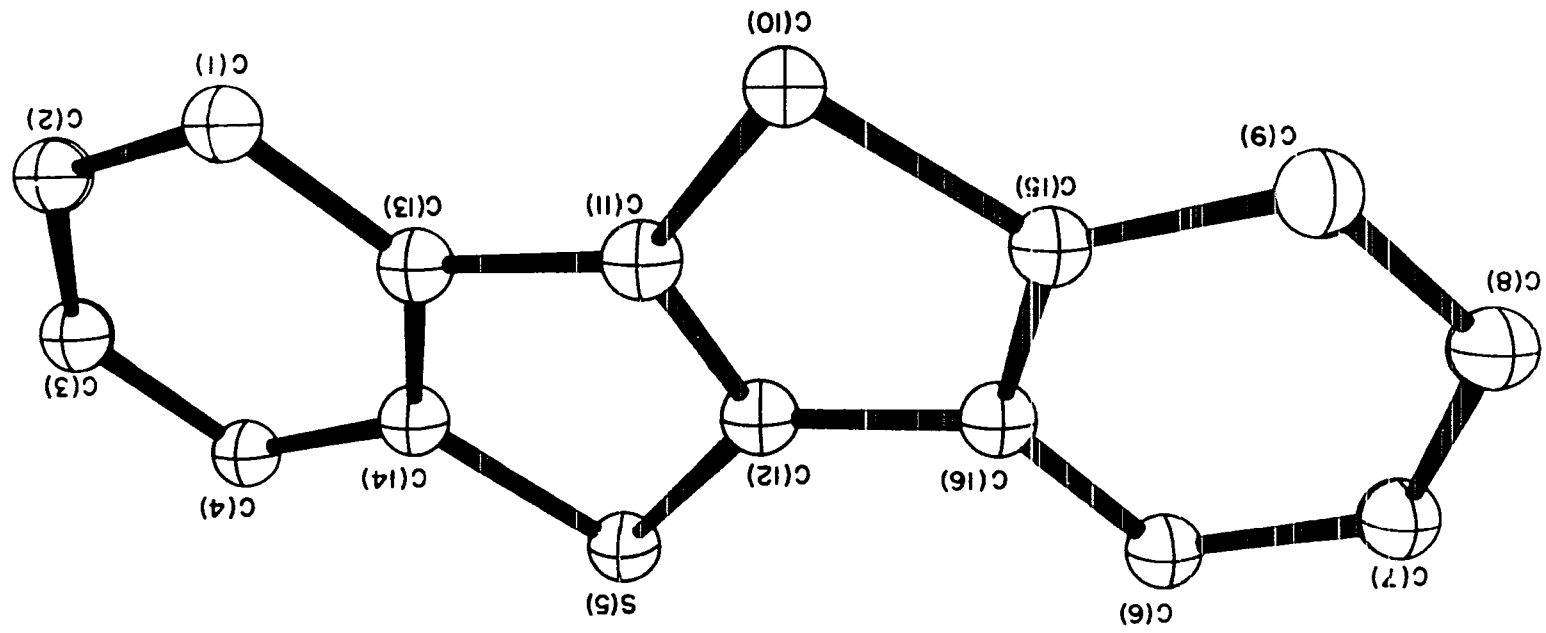

A comparison between the two types of diacetylenes 1,4-diphenylbutadiyne 54 and o-bis(phenylethynyl)benzene 55 and their reactions with sulfur dichloride^{190,192,resp.} denotes two guiding influences in determining the reaction course. First the ground state energies of the two desired products, the thiophene and thiepin, are greatly different. Second, the distance between the ends of the diacetylene moiety is closer in 55 than in 54. The second effect, while not a thermodynamic one, might have an influence on the stereochemical course of the initial attack by sulfur dichloride.

A molecule which might serve as a probe for this effect is 1,8-bis(phenylethynyl)naphthalene¹⁹³ 56. The distance between the ends of the diacetylene fragment is intermediate between that of the linear 54 and 55.

Reference to the previous sulfur dichloride addition study prescribes the addition to occur in the same manner as halogen addition. Schechter¹⁹⁴ has investigated the reaction of 56 with bromine finding across-the-fragment attack upon the forming vinyl carbonium ion by the other acetylene fragment.

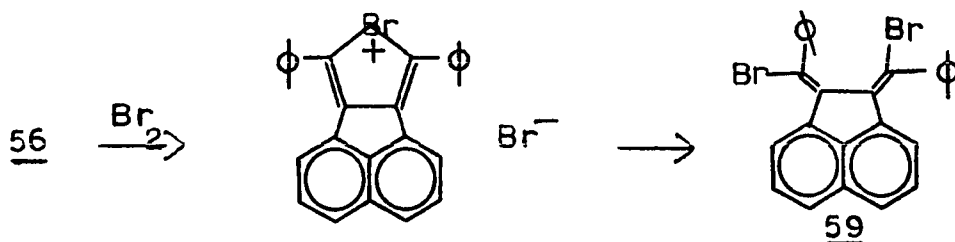

Sulfur dichloride addition might be envisioned to proceed in the same manner. Attack of the electrophilic sulfur dichloride at the most available, stericwise, site followed by ring closure and electrophilic aromatic substitution could give a fused thiophene ring system.

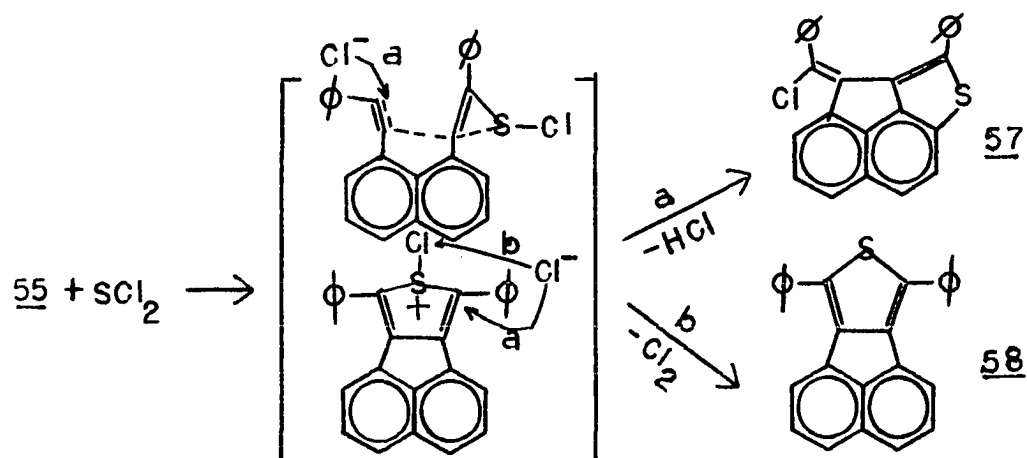

The difference in path a or b would be determined by a delicate balance of steric and electronic stabilization. Therefore, a mixture of 57 and 58 would be expected.

Slow addition of equimolar amounts of sulfur dichloride and 56 to a stirred portion of dark methylene chloride resulted in the rapid development of a deep red solution. The color was not surprising in view of the reported color of 1,2-bis(benzylidene)acenaphthene¹⁹⁵. However, Schechter¹⁹⁶ reported a white color for his bromine addition product to 56, 1,2-bis(α -bromobenzylidene)acenaphthene 59. The color

according to Schechter is due to severe twisting of the double bonds by steric interaction of the bromines with the phenyls. Since the size of chlorine is smaller than bromine, the twisting might not be as severe resulting in planar double bonds and a red color. After workup there resulted a dark, foul smelling residue. It was chromatographed on silica gel with hexane and two close-in- R_f -value components were separated. The first component 60 was a dark red crystalline material, mp $205.5^\circ - 206.5^\circ$, and was obtained in 45 percent yield. The second compound 61 was a light yellow material, mp $200^\circ - 201^\circ$, and was obtained in 30.5 percent yield. The mass spectral data for 60 was rather startling. There had been no incorporation of sulfur, only chlorine. Further, the exact mass analysis flaunted the molecular formula $C_{26}H_{14}Cl_2$, a loss of two hydrogens from the starting substrate 56. The NMR had only aromatic protons with no dramatic up or downfield shifts to betray its identity. The UV spectrum dramatically made light of the deep red color of 60, and is shown in Table 2. Compound 60 was also photolabile with the red color being discharged in a matter of minutes when photolyzed at 3500 \AA . Accurate elemental analysis for 60 could not be obtained because of this reason. The second compound 61 gave a correct analysis for $C_{26}H_{16}SCl_2$, addition of sulfur dichloride to 56. The NMR did not have any revealing resonances to permit choice

Table 2. UV Spectra of 60 and 77

Compound	Media	Wavelength A λ_{\max}	$\epsilon \times 10^{-4}$
<u>60</u>	CH ₂ Cl ₂	2095	7.25
		2650	6.55
		3300	1.81
		3485	2.05
		4010	1.04
		4210	1.30
		4445	1.18
		4950	1.18
		5150	1.25
		5450	1.02
<u>77</u>	methanol	2020	6.14
		2500	3.02
		3540	0.69
		3675	0.78
		3950	0.74
	acidic	2020	6.68
		2510	2.98
		3540	0.67
		3675	0.76
		3950	0.71
	basic	2150	9.14
		2510	2.91
		3610	0.649
		3775	0.737
		4065	0.613

between the three structures resulting of sulfenyl chloride attack at the other triple bond fragment.

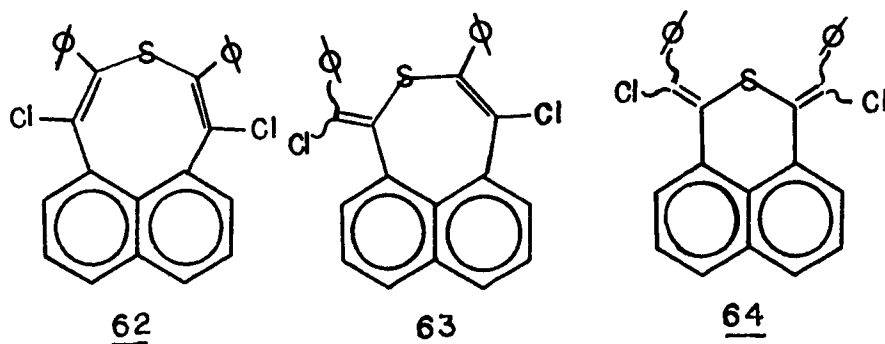

Formation of any of the three of the structures can be envisioned as resulting from initial attack of sulfur dichloride on one of the triple bonds. The formed sulfenyl-chloride then attacks the other triple bond. In the case of 55 the attack of the other triple bond was concerted with sulfenyl chloride formation making a new carbon-carbon bond. In the present case attack occurred after sulfenyl chloride formation and made a sulfide linkage. Since the substitution about the triple bonds is the same, then the difference in attack must be due to the configurational difference of the two triple bond fragments.

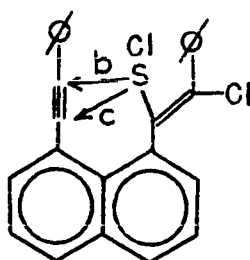
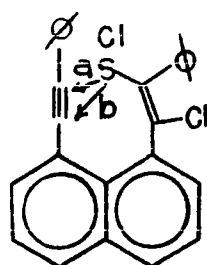

Attack a gives 62

Attack b gives 63

Attack c gives 64

In an attempt to determine the structure, the ozonation of 61 was tried. According to Banard¹⁹⁷, ozonolysis for short duration should attack all olefinic bonds, but leave the carbon-sulfur bond intact. Ozonolysis should give the following results.

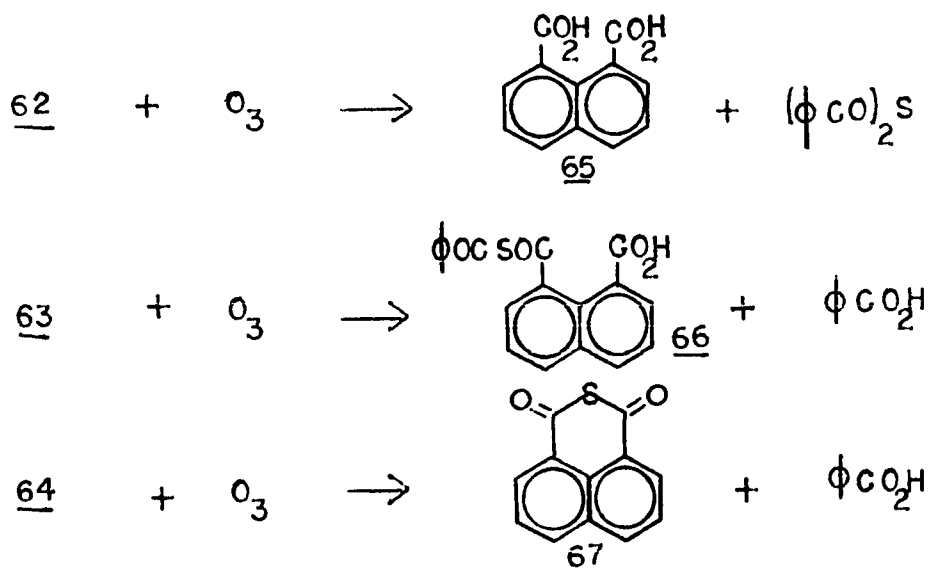

Isolation of the naphthalene containing moiety 66 or 67 will confirm structures 63 or 64. 66 and 67 should be stable compounds as they are thio-analogues of their respective anhydrides. Isolation of 65, however, does not necessitate the compound 62 for 63 and 64 will also give 65 upon further oxidation of the sulfur and hydrolysis of the sulfone. The ozonolysis results did not produce the desired compounds.

Oxidation of the thioanhydride was then followed by loss of SO_2 . The isolated product was 65 naphthalic acid. Since the compound's structure was still as hidden as snow in June, a crystal structure study was initiated. Single crystals of 61 were grown by slow crystallization from methylene chloride. The course of the analysis was routine, Patterson heavy atom method, and the details are given in the Experimental section. A computer drawing of the final model is given in Figure 18. The bond distances and angles agree with generally accepted values and are given in Tables 3 and 4. The sulfur is displaced from the plane of the other six atoms of the thiepin ring making a flattened boat conformation. The juxtaposition of the two phenyls could give rise to shielding of phenyl protons. However, the distance is too great to cause dramatic shifts. The structure of 61 is 63, then, with the phenyls pointing in the same direction. The seven membered ring is not really a true thiepin for the chlorobenzylidene group and the naphthalene ring break up the complete conjugation around the thiepin ring.

Compound 60 proved to be more interesting although it did not have the desired sulfur in the ring. The molecular weight proved a puzzle until it was learned the exact mass was not correct for $\text{C}_{26}\text{H}_{16}\text{Cl}_2$, but instead, for $\text{C}_{26}\text{H}_{14}\text{Cl}_2$. It was felt that the loss of hydrogen must have come from

Figure 18. Crystal structure of 61

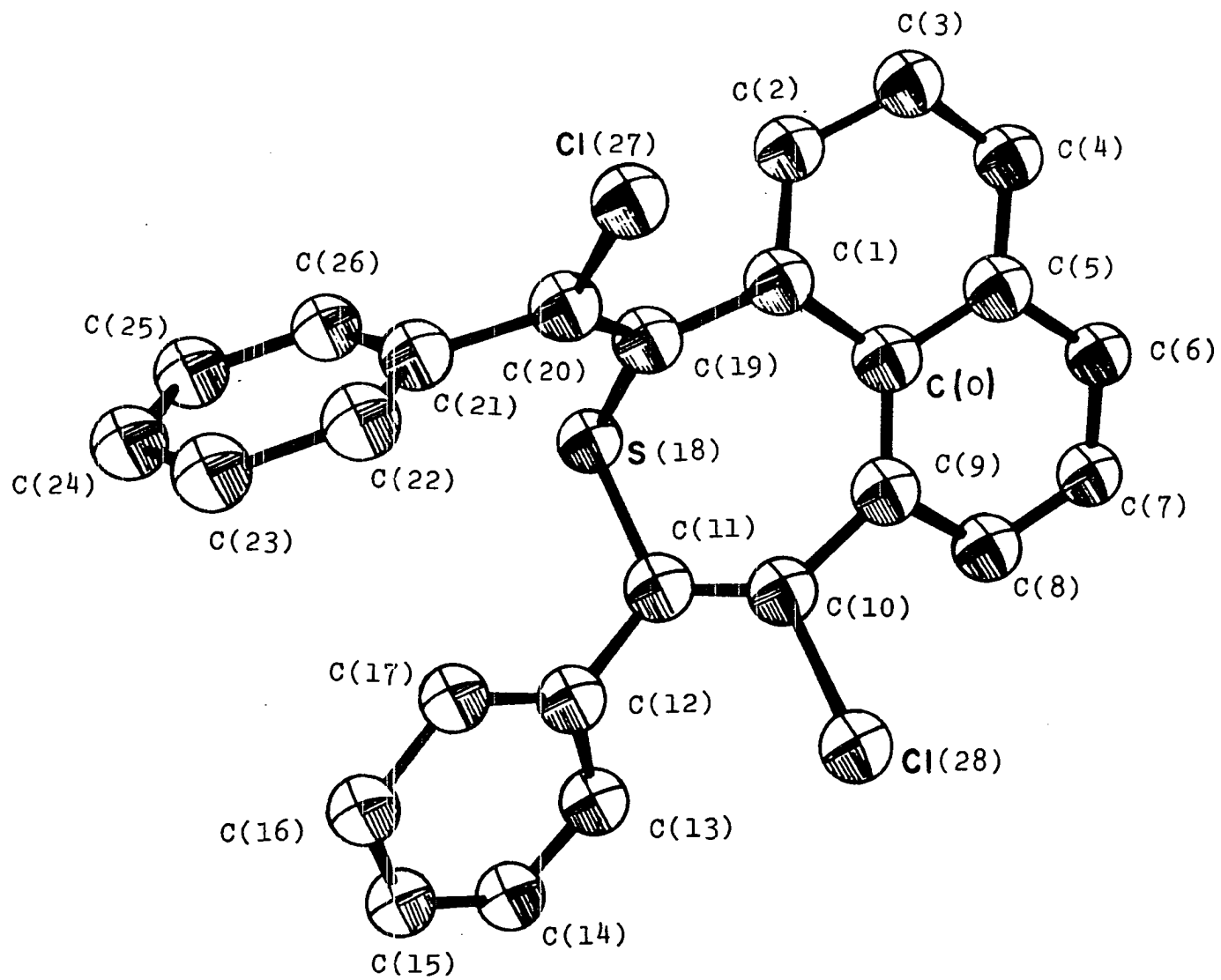

Table 3. Bond Distances of 63

Bond Between Atoms		Distance in A. \pm 0.1A
0	1	1.436
1	2	1.343
2	3	1.439
3	4	1.350
4	5	1.359
5	0	1.423
5	6	1.428
6	7	1.336
7	8	1.396
8	9	1.394
9	0	1.413
9	10	1.518
10	11	1.283
11	12	1.449
12	13	1.410
13	14	1.340
14	15	1.305
15	16	1.349
16	17	1.429
17	12	1.390
11	18	1.750
18	19	1.752
19	1	1.473
19	20	1.332
20	21	1.472
21	22	1.392
22	23	1.377
23	24	1.369
24	25	1.367
25	26	1.369
10	28	1.777
20	27	1.714

Table 4. Bond Angles of 63

Angle Between Atoms	Value in Degrees \pm 1.0
19-1-2	116.7
0-1-2	120.9
1-2-3	122.0
2-3-4	117.4
3-4-5	121.6
0-5-6	118.3
4-5-0	118.6
5-6-7	121.5
6-7-8	121.0
7-8-9	120.0
8-9-10	111.4
9-0-5	118.9
10-11-18	117.4
11-12-13	121.9
12-13-14	120.2
13-14-15	122.0
14-15-16	122.7
15-16-17	118.2
16-17-12	119.1
11-18-19	100.1
18-19-1	115.4
1-19-20	124.2
19-20-27	121.3
19-20-21	126.2
20-21-22	120.2
21-22-23	119.6
22-23-24	120.3
23-24-25	120.1
24-25-26	119.8
25-26-21	121.2
9-10-28	112.4
11-10-28	117.0

an intermediate having only two chlorines added to 56. Three possible structures may be written for this intermediate. They have the skeletal configurations of a pleiadiene^{198,199,200} 68, and acenaphthene^{201,195} 69, and perinaphthene²⁰² 70.

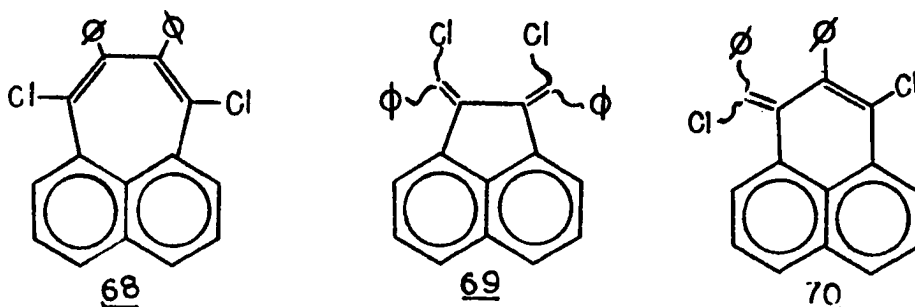

Sulfur dichloride undergoes disproportionation to sulfur monochloride and chlorine within a few hours²⁰³. Knowing this testy fact led to the hypothesis that 60 might result from simple chlorine addition to 56 then hydrogen loss because of the conditions in the reaction medium. Schechter postulates a bromonium ion intermediate in the mechanism for halogen addition to 55. Although a chloronium ion is less stable than its bromonium brother, addition of these two types of halogens usually occurs in the same manner²⁰⁴. If initial addition of chlorine is taking place, then yields comparable to that found for 60 should be had from chlorine addition. Dropwise addition of an equimolar, known concentration of chlorine in chloroform to 56 in chloroform over a period of ca. three hours gave only 0.25 percent yield of a red powder analyzing for $C_{26}H_{16}Cl_2$. The bulk of the reaction mixture had tri and tetrachlorinated

leaving considerable 56 behind. If the chlorination mechanism were operative, then reaction mixtures analogous to the tetrachlorinated mixtures should have been found. In addition the yields of the dichlorinated product should have been minor in the reaction of 56 with sulfur dichloride. Therefore, the chlorine addition mechanism is ruled out.

The aforementioned intermediate (68, 69 or 70) could have resulted from sulfur dichloride addition, sulfur expulsion and dehydrogenation by the sulfur produced. The dehydrogenation-coupling step is not common, but may result from the proximity of the hydrogens. Dehydrogenation of 68, 69 or 70 may result in the following four structures.

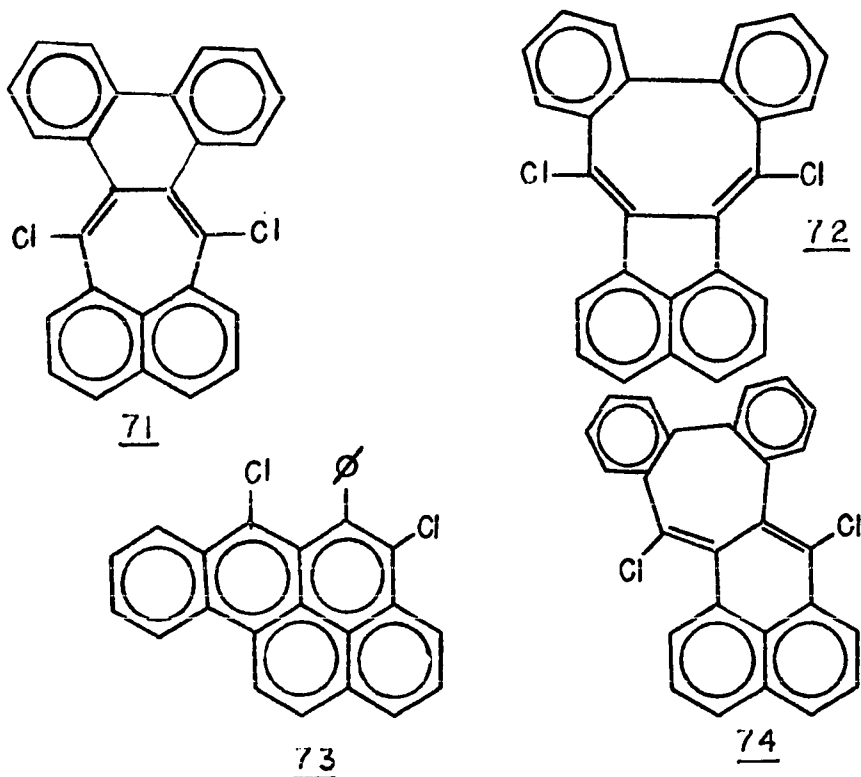

Another structure, 75, not having an obvious mechanistic rational, but fitting the molecular weight, is also drawn. However, this structure necessitates the movement of two hydrogens in addition to the loss of two.

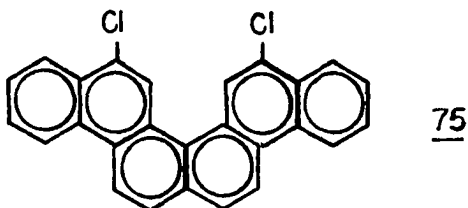

Structures 71 and 72 have one thing in common; they both have an s- cis diene fragment. Such a diene configuration is correct for the classic Diels-Alder reaction with maleic anhydride. Reaction of 60 with maleic anhydride in refluxing diglyme for two weeks gave no reaction. The starting material 60 was isolated in 50 percent yield, quite a bit on a 30 mg. scale. The hydrogenation of 60 didn't do much better. A solution of 60 in ethyl acetate was stirred at room temperature and under an atmospheric pressure of hydrogen for two days. Isolation of the residue gave a good yield of starting material 60. The reaction with di-ironnonacarbonyl was tried in hopes that a dichlorocyclobutene fragment was present. However, the compound 60 was recovered in an unreacted state. Dechlorination with sodium in liquid ammonia proved to be more than the molecule could stand. The reaction replaced the chlorine

with hydrogen. But, it also employed Birch reduction on 60, giving it a partially hydrogenated ring structure. The m/e values from the mass spectrum were a series of peaks at two unit distances starting at 328, the removal of two chlorines and addition of two hydrogens, and going to 334, addition of six hydrogens to (m/e) 328.

The reaction of methyl lithium with 60 gave a high yield reaction. Adding a solution of methyl lithium in hexane to a small portion of 60 in THF at 0°C and under nitrogen caused a color change from red to violet immediately. Isolation of the reaction material by water workup and prep TLC gave a red compound 76 analyzing for 60 plus methane. The IR spectrum of 76 was not too different from that of 60 indicating no gross change in the molecular structure had taken place.

The oxidation of 60 with chromium trioxide in acetic acid also was a high yield reaction. Stirring a heterogeneous mixture of 60 in acetic acid, water and chromium trioxide at room temperature overnight caused the formation of a yellow solid. Filtration and water washing gave an almost quantitative yield of the yellow solid 77 mp 206° to 207° C. The IR flashed two medium intense bands at 1670 and 1645 cm⁻¹. Although the absorptions are too low for a carbonyl, they could have resulted from a quinone type structure. But reaction of 77 with 2,4-DNP gave no

hydrazone. The IR of the reaction material was the same as 77. The UV, given in Table 2, in neutral, basic and acidic media told a revealing story. The longest wavelength bands underwent a bathochromic shift in basic media. The exact mass analysis crowned the attempt at identification. It said two oxygens had been added to 60 and nothing had been lost. Oxidation of vinyl chlorides usually results in loss of the chlorine. Therefore, the identification had been thoroughly confused.

Of all the proposed structures, 71 through 75, the only two which fit the data are 74 and 71. 74's transformations are discussed. Reaction with maleic anhydride should not occur because two of the double bonds in the seven membered ring are also in benzene rings. The red perinaphthene anion according to Pettit²⁰² and others²⁰⁵ should have a stability resulting from its 14 pi electron system. Polarization of the molecule 74 in the manner indicated gives a resonance form having the perinaphthene anion and the tropylium cation, two stable ions. House²⁰⁶ points out relevant cases of reduction by referencing the well-known fact that benzene is harder to reduce than acetone. The stability derived from the polar resonance form of 74 contributes inertness toward hydrogenation under the mild conditions employed. The touchstone is the two reactions that rearranged or affected 60 in good yield. The polar

structure of 74 begs attack by methyl lithium. Protonation of the resultant anion gives the methane addition product. Mild oxidation of 74 also would produce a compound fitting the oxidation data for 60. Attack does not occur at the vinyl chloride but at the position of partial negative charge²⁰⁷, the naphthalene ring. Oxidation at the para positions followed by hydrolysis of the intermediate would give a phenol. Phenols show bathochromic shifts in the UV when in basic media as 77 did. The IR absorptions could be due to polarized nature of the phenol. The discussed transformations of 74 are shown in Scheme 4.

The meanderings bring home a note about the electronic spectra of 74 itself. The structure has hidden in it a dibenzo(a,c)cyclohepten-5-ium ion²⁰⁸ like fragment. The corresponding protonated tropyliene alcohols^{208,209} have very intense colors in the UV. They are shown on page 166.

Some of the other possible structures, 72, 73, 75, do not have a common ground for addition of methyl lithium and the UV spectrum. 72 cannot explain the maleic anhydride results. 73 can explain the results of hydrogenation and maleic anhydride, but not that of methyllithium. 75 is even more remote and cannot explain the methyllithium results.

Since 60 and 61 were produced in ca. equal yields, it would seem the mechanisms for preparation of 60 and 61 must compete successfully with each other. Such a requirement

Scheme 4

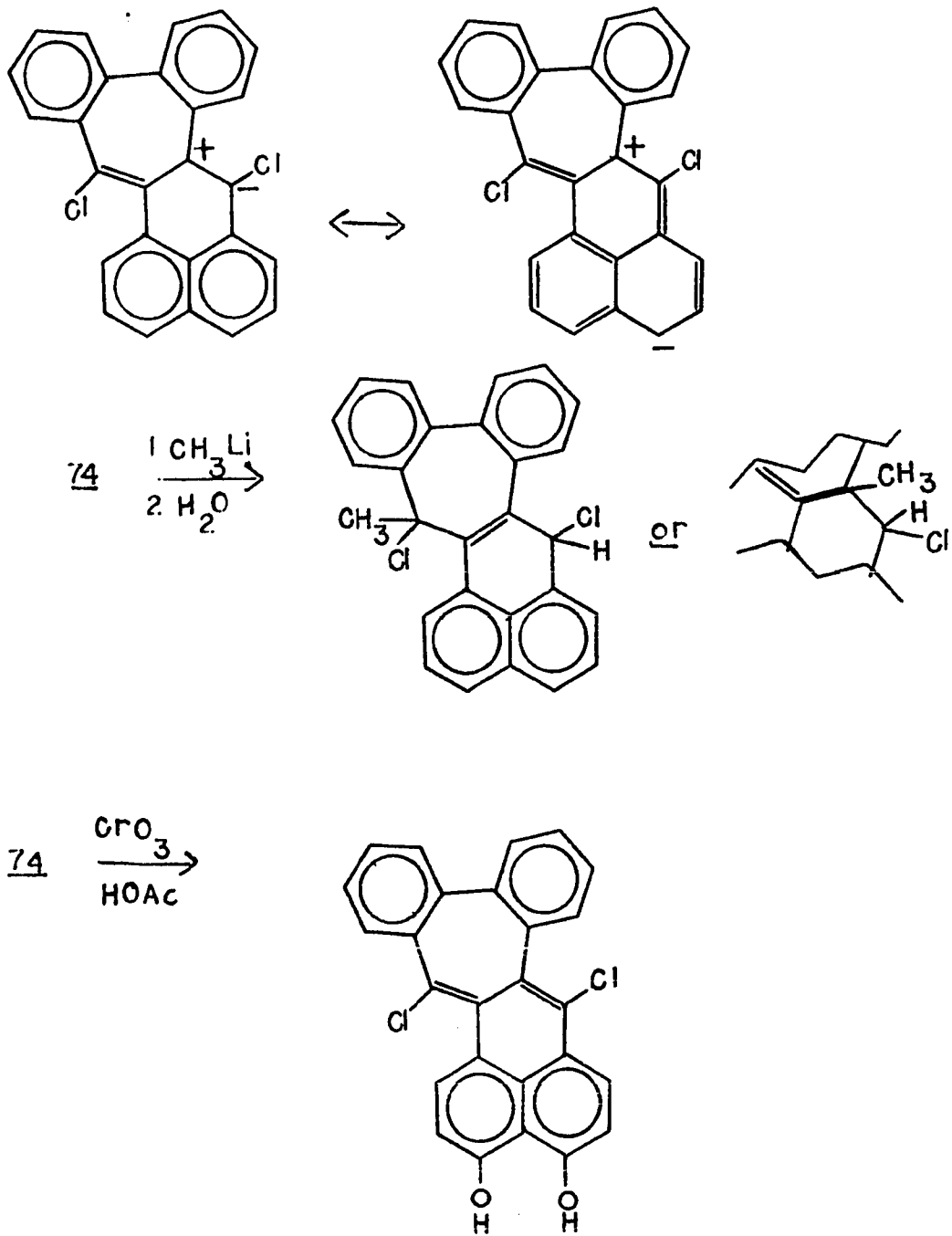

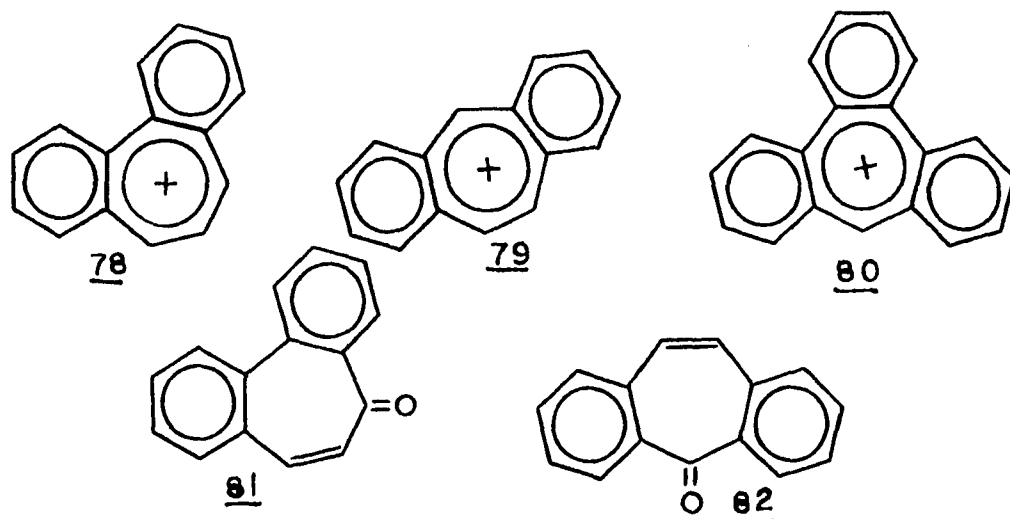

Compound	λ_{\max} Å	$\epsilon \times 10^{-4}$	Ref. No.
78	4570	1.32	209
	3170	1.74	
	3000	3.10	
	2810	4.18	
	2480	1.58	
79	5400	0.32	209
	5080	0.33	
	3970	0.87	
	3790	1.02	
	3060	12.3	
	2690	0.66	
	2370	1.48	
80	5660	0.21	209
	4100	0.91	
	2900	2.10	
	2500	4.07	
81 alcohol	3450	0.25	209
	2940	0.63	
	2700	2.00	
	2280	1.58	
81 in H ₂ SO ₄	3920	1.0	209
	3120	1.26	
	2860	3.98	
	2400	1.58	
82	3030	0.05	210
	2520	0.13	

is easiest to explain when the mechanisms have a common intermediate. Formation of 61 occurs by electrophilic attack of the sulfenyl chloride on the other triple bond. According to the proposed mechanism for sulfenyl chloride formation, there is involved a thiirenium cation. Displacement of one C-S bond by chloride then forms the sulfenyl chloride¹⁸⁸. Previously, it was found that nucleophilic attack by the other triple bond was in concert with the thiirenium cation formation yielding exclusively 50. Such a triple bond attack in this case could have a higher energy of activation; therefore, nucleophilic attack by chloride to give 63 and the triple bond to give 74 are competitive.

There are two pathways for preparation of sulfides from the intermediate sulfenyl chloride (see page 152), path a produces an eight membered ring, path b gives the seven one found. The absence of the eight membered ring 62 can explain structure 71. Thus, there is a common intermediate for the preparation of 71 also. After formation of 62 the divinyl sulfide fragment can close through a six pi electron transition state to give a tetravalent sulfur. Analogous systems have been reported by Schlessinger²¹⁰. Rearrangement of this intermediate followed by radical expulsion of sulfur would give 71. 71 can also explain the reaction results with maleic anhydride methyllithium, chromium trioxide, and hydrogen for the same reasons as 74. These

transformations are shown in Scheme 6. The mechanism of formation of 71 and 74 is shown in Scheme 5.

A definitive answer awaits a crystal structure.

Scheme 5

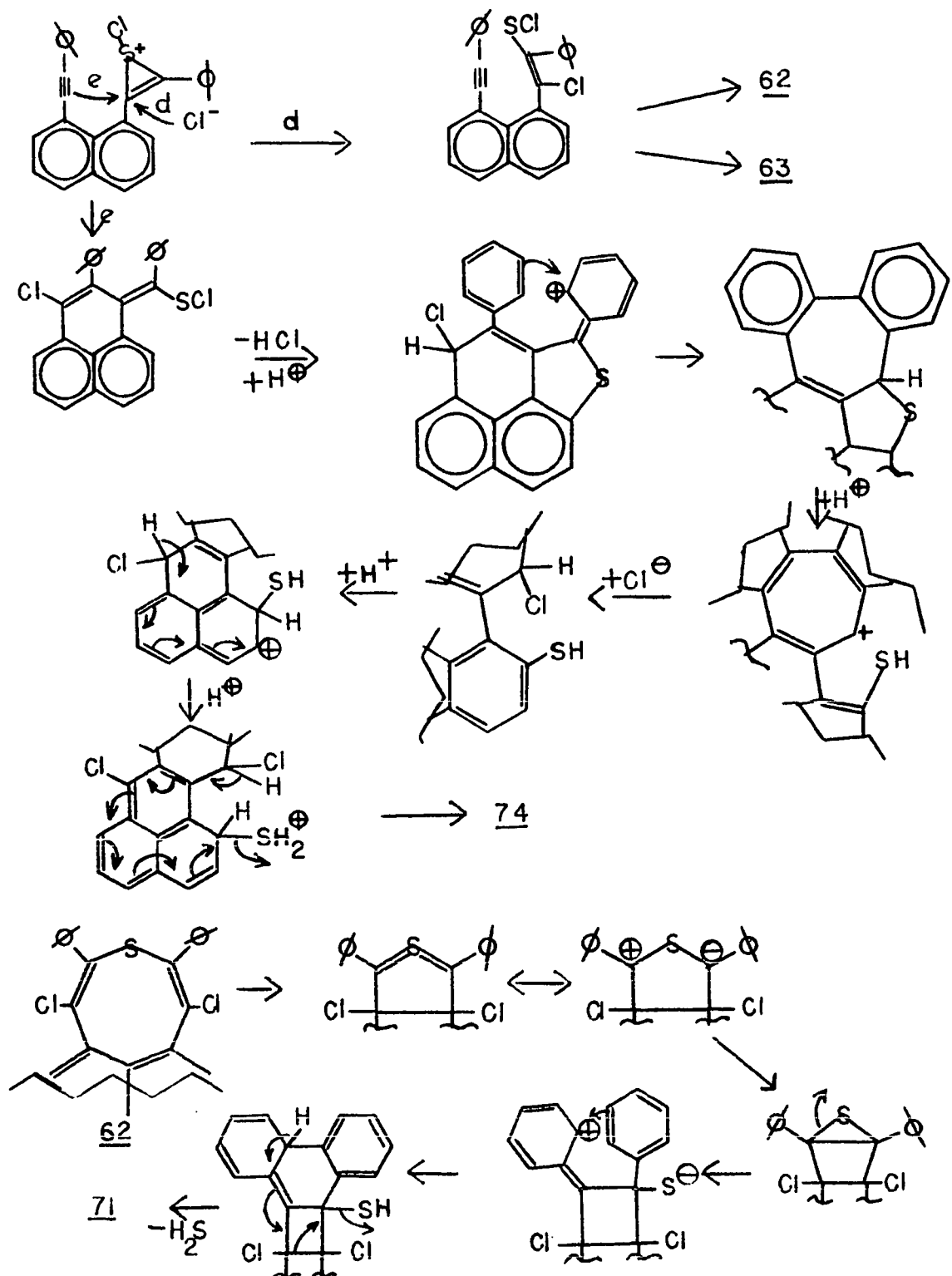

Scheme 6

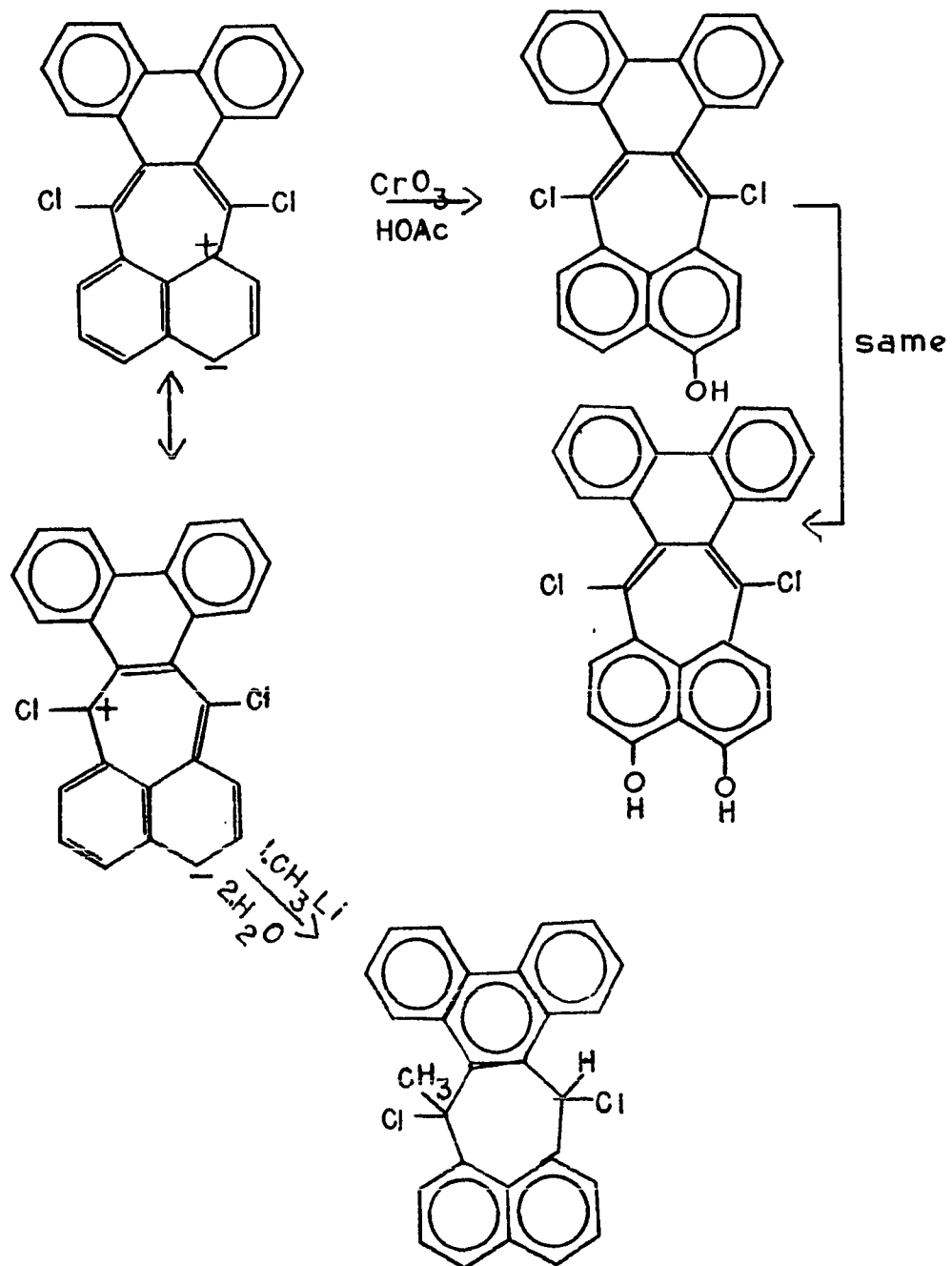

EXPERIMENTAL

General Information

Infrared spectra were recorded on Perkin-Elmer Model 21 or 12 spectrophotometers. Proton NMR spectra were determined on Perkin-Elmer R-20-B or Varian A-60 instruments. The UV spectra were determined with a Cary Model 14 instrument. Analyses were carried out by Ilse Beetz Mikroanalytisches Laboratorium, Kronach, Western Germany. The melting points are uncorrected. All starting chemicals for the various syntheses were commercially available. Organometallic reagents were purchased from Ventron Corp., Beverly, Mass. Solvents were used directly from bottles unless otherwise indicated.

1,1-dimethyl-2,5-diphenylsilole (1). The procedure of Weyenberg and Gilman, Ref. 42, was used mp 130-133° C (lit. mp 131-133° C).

1,4-dibromo-1,4-diphenylbutadiene. The synthesis of it followed the method of Weyenberg and Gilman, Ref. 42, mp 120-122° C (lit. mp 121-123° C).

Preparation of 1,1-dimethyl-2,5-diphenylsilole (1) using 2,3-dichloro-4,5-dicyanoquinone (DDQ). A 26.4 gm (0.099 mole) sample of 1,1-dimethyl-2,5-diphenylsilacyclopentane in 100 ml dry (over sodium) benzene was added dropwise to a stirred solution of 47.7 gm (0.21 mole) DDQ in 600 ml benzene at room temperature and under nitrogen. After the addition was complete (approximately 1 hour), the mixture was refluxed for

16 hours under a nitrogen atmosphere. When the solution was cooled, the hydroquinone was filtered off to give 43.1 gm of product. The benzene was removed in vacuo. The residue redissolved in methylene chloride and chromatographed on a 6x6 cm column of alumina packed with hexane. Elution with 10% ethyl ether/hexane removed the silole. Removal of solvent in vacuo and recrystallization from methylene chloride/hexane gave 22.5 gm 1,1-dimethyl-2,5-diphenylsilole (86%).

1,1-dimethyl-2,5-diphenylstannole (5). The synthesis of this compound used the procedure of Weyenberg and Gilman, Ref. 42, mp 118-120° C (lit. mp 119-121° C).

1,2,5-triphenylphosphole (8). Method of Cookson, Ref. 100, mp 130-134° C (lit. mp 133-134° C).

Synthesis of 1,2,5-triphenylpyrrole (7). The method of Schulte, Ref. 94, was used to make this compound. 2.02 Gm (10 mmoles) 1,4-diphenylbutadiyne and 0.93 gm (10 mmoles) aniline were put in a flask with a catalytic amount of cuprous chloride and heated at 150° C for 1.5 hours. The sample was worked up by dissolving the residue in methylene chloride, filtering, evaporating the methylene chloride and crystallizing from acetic acid/ethanol. The resultant crystals were washed with cold methylene chloride to give 1.521 gm, mp 226-230° C (lit. mp 229-230° C) (Ref. 94).

NMR Aromatic multiplet δ 7.18 (15 H), singlet δ 6.48 (2 H).

Synthesis of 2,5-diphenyltellurophene (10). Into a flask under nitrogen atmosphere was put a solution of 5.25 gm (0.0302 moles) sodium telluride and 80 ml reagent methanol. Into this stirred solution was dripped 6.02 gm (0.0298 moles) 1,4-diphenylbutadiyne at room temperature in 100 ml acetone. The reactants were stirred for 20 hours until the purple color had disappeared. The final solution was worked up by distilling most of the methanol, adding 15 ml water and extracting with methylene chloride. The organic layer was separated, dried with magnesium sulfate, filtered and solvent removed in vacuo to give green crystals. Recrystallization from ethyl ether/hexane gave 7.512 gm light yellow crystals, mp 222-223° C.

NMR Aromatic multiplet δ 7.60-7.27 (5 H); singlet δ 7.85 (1 H).

Analysis calculated C-57.91, H-3.64; (C₁₆H₁₂Te)

Analysis found C-57.74, H-3.51

Synthesis of 1,1-dimethyl-2,5-diphenylgermole (4). A 100 ml three neck "dropping funnel" flask was fitted with a Trubore stirrer, dropping funnel, gas inlet and outlet tubes for argon and an ice bath. Into this flask was put a solution of 40 ml dry ethyl ether and 2.047 gm (5.65 mmoles) 1,4-dibromo-1,4-diphenylbutadiene. To this solution at ice bath temperature and under argon was added 7.1 ml (11.06

mmoles) of a 15% solution of n-butyllithium in hexane. After addition was complete the solution was warmed to room temperature. It was then added dropwise to a stirred solution of 80 ml dry ethyl ether and 1.15 gm (6.64 mmoles) dimethyldichlorogermane. After stirring for several hours, the solution was filtered through neutral alumina. The solvent removed in vacuo and the residue crystallized from ethyl ether and hexane to give yellow crystals, 1.421 gm, mp 128° C.

NMR Aromatic multiplet δ 7.40 to 7.15; germanium methyl singlet δ 0.68.

Mass Spectrum 308-100%, 306-73%, 304-54% (M+ region)

Analysis calculated C-70.44, H-5.91; (C₁₈H₁₈Ge)

Analysis found C-70.61, H-6.12

Photolysis of 1,1-dimethyl-2,5-diphenylsilole (1) at 3000 Å to give (2). A solution of 1.041 gm 1,1-dimethyl-2,5-diphenylsilole in 350 ml dry (distilled from lithium aluminum hydride) diethyl ether was prepared. This solution was then put into the irradiation vessel; the Pyrex immersion lamp jacket with a Hanovia 450 watt medium pressure mercury arc lamp put into the solution and a nitrogen purge started. After ca. 10 minutes of purging, photolysis was initiated. After 4 hours a TLC on silica gel with hexane eluant indicated the silole to be almost completely gone.

Irradiation for an additional 2 hours gave no further change according to TLC comparison.

The irradiation was then stopped; the solvent removed in vacuo to give a solid residue. Chromatography on a 3.5 x 20 cm column of silica gel packed with hexane separated the unreacted silole from its dimer. Elution with hexane removed the silole. Elution with 10% ether in hexane removed the dimer. Removal of solvent in vacuo from the dimer fractions followed by crystallization from ethyl ether in hexane gave 0.761 gm dimer (74% based on weight of starting material), mp 197-198° C.

NMR Multiplet (22 H) aromatic and olefinic protons, center, δ 7.09; doublet ($J=3.6$ Hz) two allylic protons, center, δ 4.26; two singlets (6 H each) methyl protons δ 0.31 and δ -0.31.

Mass Spectrum 70 eV 524-10%, 262-100%, 232-60%, 16 eV 524-25%, 262-100%.

Analysis calculated C-82.38, H-6.91; ($C_{36}H_{36}Si_2$)

Analysis found C-82.15, H-6.81

Photolysis of 1,1-dimethyl-2,5-diphenylgermole (4) at 3000 Å to give (6). A solution of 0.5230 gm (1.71 mmoles) 1,1-dimethyl-2,5-diphenylgermole in 300 ml ethyl ether was irradiated through Pyrex at 15° C with a 450 watt Hanovia medium pressure mercury arc lamp. The solution was constantly

purged with nitrogen during irradiation. A silica gel TLC check showed the germole (4) to be gone after 8 hours of irradiation. The solvent was then removed in vacuo and the residue recrystallized from ethyl ether/hexane to give 0.4180 gm (80%) white cubes, mp 215-217° C.

NMR Aromatic multiplet δ 7.15 center (11 H); doublet, center, δ 4.35 ($J=6$ Hz) (1 H); singlet δ 0.44 (3 H); singlet δ -0.23 (3 H).

Analysis calculated C-70.44, H-5.91; ($C_{36}H_{36}Ge_2$)

Analysis found C-70.22, H-5.76

Sample NMR is identical in shape to that from the silole 2+2 dimer.

Mass Spectrum 70 eV 608 to 616 ca. 10% (limit of spectrometer), 308-74%, 306-54%, 304-40%.

Photolysis of 1,1-dimethyl-2,5-diphenylstannole (5). A solution of 0.912 gm 1,1-dimethyl-2,5-diphenylstannole in 250 ml dry ethyl ether was irradiated with a 450 watt Hanovia medium pressure mercury arc lamp through Pyrex at 15° C while purging the solution with nitrogen. After 3 hours a silica gel TLC comparison of reaction material with starting material showed it to be gone. The solution was then filtered yielding 0.216 gm white noncrystalline material. Mass Spectrum 70 eV (parent ion region) 378-26%, 376-37%, 374-100%, 372-74%, 370-47%.

The mother liquor was then concentrated and the residue components separated by preparative TLC (silica gel, hexane elutions).

Mass spectra of the four bands that developed did not show either stannole dimer or monomer.

Photolysis of 1,1-dimethyl-2,5-diphenyl-1-stannole (5)
at 3000 \AA . A solution of 0.928 gm stannole in ca. 320 ml dry ethyl ether was put into the well of an irradiation vessel. The Pyrex immersion lamp jacket containing a 450 watt Hanovia medium pressure mercury arc lamp was put into the solution and a nitrogen purge started. After ca. 10 minutes of purging, the photolysis was started. After 3.5 hours a TLC on silica gel with hexane eluant showed the stannole to be gone, with the concomitant appearance of a material having an R_f value ca. 25% that of the stannole.

The photolysis was then stopped and the solvent removed in vacuo. The resulting residue was redissolved in methylene chloride and recrystallization attempted from ethyl ether/hexane. There was a brown amorphous solid which did not dissolve in the methylene chloride and was filtered off to give 0.151 gm, decomposes ca. 240° C with no melting.

The mass spectrum showed the presence of a tin polymer of the formula $(\text{Sn})_N$.

Photolysis of 1,2,5-triphenylphosphole (8) at 3000 Å to give (9). A solution of 1.00 gm (3.21 mmoles) 1,2,5-triphenylphosphole was put in 300 ml dry THF and irradiated through Pyrex at 15° C with a 450 watt Hanovia medium pressure mercury arc lamp. During the photolysis the solution was constantly purged with nitrogen. After 6 hours a white precipitate had fallen out of solution. The solution was filtered to give 0.320 gm white solid. Removal of solvent in vacuo followed by crystallization from methylene chloride/hexane gave an additional 0.420 gm white powder, mp 229-230° C.

NMR Aromatic and olefinic multiplet (32 H) centered at δ 7.03; multiplet (2 H) δ 4.88 collapsed to a doublet upon irradiation at phosphorus (24.2897 Hz).

Analysis calculated C-84.60%, H-5.49%; (C₄₄H₃₄P₂)

Analysis found C-84.44%, H-5.52%

Mass Spectrum 16 eV 312-100%, 624-2%.

Photolysis of 1,2,5-triphenylpyrrole (7) at 2500 Å and greater. A solution of 0.47 gm (1.63 mmoles) (7) in 300 ml dry THF was photolyzed through Vicor (transmittance wave length greater than 2500 Å) at 15° C with a 450 watt medium pressure mercury arc lamp (Hanovia). The solution was constantly purged with nitrogen during photolysis. After photolysis for 6 hours the solution was worked up by

removing the solvent in vacuo and chromatographing the residue on a 4.0 x 30 cm column of silica gel packed in hexane. All fractions showed nondescriptive NMR's indicating the pyrrole had decomposed.

Photolysis of 1,2,5-triphenylpyrrole (7) at 3000 Å. A solution of 0.4125 gm (1.63 mmoles) 1,2,5-triphenylpyrrole in 300 ml dry THF was photolyzed through Pyrex at 15° C with a 450 watt Hanovia medium pressure mercury arc lamp. The solution was constantly purged with nitrogen during the photolysis. After 8.5 hours the solution was worked up by removing the solvent in vacuo. The residue was crystallized from ethyl ether/hexane to give 0.410 gm crystals. The NMR showed them to be identical to starting material.

Photolysis of 2,5-diphenyltellurophene (10) at 3000 Å. A 1.00 gm (2.65 mmoles) 2,5-diphenyltellurophene sample was put in 300 ml dry THF and irradiated through Pyrex at 15° C with a 450 watt medium pressure mercury arc lamp (Hanovia). During the irradiation the sample was constantly purged with nitrogen. A silica gel TLC check at various intervals up to 18 hours revealed only the presence of starting material. At the end of 18 hours, the photolysis was stopped, the solvent removed in vacuo and an NMR taken of the residue. The NMR was identical to the starting material. Crystallization from

ethyl ether/hexane gave 0.820 gm (82%) starting material, mp 222° C.

Photolysis of 1,1-dimethyl-2,5-diphenylsilole (1) (solid state) to give (2). A 3.12 gm 1,1-dimethyl-2,5-diphenylsilole sample was slightly crushed and then spread about an aluminum foil strip. The foil strip was then strapped to the immersion condenser for a Hanovia 450 watt mercury arc lamp and put into a "dry box" filled with nitrogen. The lamp was inserted in the well and photolysis initiated while keeping the sample cool with the immersion jacket. After two days irradiation time, the sample was removed from the apparatus, dissolved in methylene chloride and chromatographed on a 3.6 x 30 cm column of silica gel packed with hexane. Elution with hexane removed unreacted silole. Elution with 30% ethyl ether in hexane removed a second band. Removal of solvent in vacuo and recrystallization of the residue from ethyl ether/hexane gave 2.312 gm white crystals, mp 194-196° C. The NMR was identical with the silole dimer produced from solution photolysis.

Photolysis of 1,1-dimethyl-2,5-diphenylsilole (1) at 3000 and 2300 Å. A solution of 0.200 gm (0.764 mmoles) 1,1-dimethyl-2,5-diphenylsilole in 2.5 ml deuteriochloroform was put in a quartz NMR tube and degassed with nitrogen for

10 minutes. The sample was then sealed and photolyzed at 3000 Å with a Rayonet photochemical reactor for 2 hours. The NMR showed the conversion of the silole to the silole dimer (2) at about 56% (dimer silicon methyls at 0.31 δ ppm and -0.31 δ ppm). Irradiation of the sample then at 2537 Å with a Rayonet photochemical reactor for 2 hours showed the conversion of the dimer, identified by two singlets at δ 0.31 and δ -0.31, back to the monomer, identified by a singlet at δ 0.500.

Photolysis of 1,1-dimethyl-2,5-diphenylsilole (1) and 1,2,5-triphenylphosphole (8) at 3000 Å. A solution of 0.6458 gm (2.47 mmoles) 1,1-dimethyl-2,5-diphenylsilole and 0.6446 gm (2.07 mmoles) 1,2,5-triphenylphosphole in 300 ml dry THF was irradiated at 15° C through Pyrex with a 450 watt medium pressure mercury arc lamp (Hanovia). The solution was constantly purged with nitrogen during the irradiation. A silica gel TLC check showed significant reaction after 4 hours. After irradiation for 8 hours, a solid had separated which was filtered to give 0.023 gm, mp greater than 290° C. The solvent was removed in vacuo and the residue chromatographed on a 4.0 x 30 cm column of silica gel packed in hexane. Elution with hexane removed unreacted silole and phosphole. Elution with ethyl ether removed the silole dimer, mp 189-191° C, 0.121 gm. Compound is identical by

NMR with an authentic sample of the silole dimer. Elution with acetone gave a second compound, mp 247-249° C, 0.769 gm.

NMR Aromatic and olefinic multiplet, center, δ 7.10 (27 H); singlet δ 0.31 (3 H); singlet δ -0.27 (3 H).

Mass Spectrum 20 eV 575-8.2%, 330-100%, 312-10.2%, 262-64%.

Photolysis of 1,1-dimethyl-2,5-diphenylsilole (1) with phenylacetylene as a solvent at 3000 Å. A solution of 3 ml phenylacetylene and 0.200 gm (0.764 mmoles) 1,1-dimethyl-2,5-diphenylsilole was put into an NMR tube, degassed with argon for 10 minutes, sealed and irradiated at 3000 Å with a Rayonette photochemical reactor. Integration by NMR of the acetylene proton to the silicon methyl protons showed the concentration to be 4% silole in phenylacetylene. An NMR of the solution at 2.5 hours showed the presence of silole, silole dimer and phenylacetylene identical with a mixture of silole, authentic silole dimer and phenylacetylene. NMR checks at various periods up to 24 hours irradiation time showed no new products.

Photolysis of dimethyldiphenylsilole (1) in dimethoxyethylene (12). A (0.993 Molar) solution of 0.5929 gm (2.08 x 10⁻³ moles) dimethyldiphenylsilole and 2.1 ml 1,1-dimethoxyethylene was put in a quartz NMR tube and photolyzed at 3000 Å in a Rayonet photochemical reactor. The extent of

reaction was followed by integrating the product (dimer (2)) silicon methyl peaks and the silole (1) silicon methyl peak. Percent of product was found by adding the two areas and dividing the amount of product by the total.

Table 5: Extent of the Silole Photolysis Reaction

Time of the Irradiation (hours)	% Product (<u>2</u>)	% Reactant (<u>1</u>)	(<u>1</u>) Molar
0.0	0	100	0.99
0.5	11	81	0.88
1.0	28	72	0.714
3.0	43	57	0.564
6.0	59	41	0.406
10.5	61	39	0.386
22.5	70	30	0.297

A graph of $1/A$ versus time gives $K = 7.3 \times 10^{-5} \text{m}^{-1} \text{sec}^{-1}$ from the first part of the curve.

Photolysis of dimethyldiphenylsilole (1) in 1,1-dimethoxyethylene (2) at two wavelengths. Into each of two NMR tubes, one of quartz, the other of Pyrex, was put a 0.1 molar solution of dimethyldiphenylsilole in

dimethoxyethylene. The samples were degassed with nitrogen, capped and irradiated at 3000 Å in a Rayonet photochemical reactor. After 3.5 hours irradiation time NMR's were taken. They showed dimer (2) and adduct (13) to be present in equal concentration. Irradiation for 2 more hours did not change their relative concentrations or the total amount reacted relative to silole. The lamps were then changed to 2537 Å and the quartz sample tube irradiated for 12 hours. The NMR showed destruction of both the adduct and dimer to give only silole.

The excess dimethoxyethylene was removed from the Pyrex sample tube and deuteriochloroform added. The NMR showed silicon methyl resonances at δ 0.54 (silole), δ 0.44 and δ -0.20 equal intensity adduct (13), δ 0.34 and δ -0.34 (dimer (2)) equal intensity.

Photolysis of dimethyldiphenylsilole (1) in 1,1-dimethoxyethylene (12) at 0.1 molar to give (13). A solution of 0.8303 cm (3.17 x 10⁻³ moles) dimethyldiphenylsilole and 30 ml 1,1-dimethoxyethylene was put in an 80 ml Pyrex tube and degassed for three minutes with nitrogen. The tube was capped, shaken, degassed again, then capped. The solution was photolyzed at 3000 Å in a Rayonet photoreactor for 24 hours. The excess solvent was removed by vacuum distillation taking care not to heat the pot above 50° C. The residue

was redissolved in a minimum amount of methylene chloride and chromatographed on a 6.5 x 28 cm column of silica gel packed in hexane. Elution with hexane removed unreacted silole. Elution with 5% ether in hexane enabled removal and separation of the dimer from the adduct. R_f values, silole 0.5, dimer 0.43, adduct 0.27, were obtained with the 5% ether/hexane. Removal of solvent from the adduct fractions in vacuo gave 0.2126 gm oil which was crystallized from hexane, mp 82.5-85° C.

Analysis calculated C-75.38, H-7.48; (C₂₂H₂₆SiO₂)

Analysis found C-75.50, H-7.34

NMR Aromatic multiplet δ 7.30-6.80 (11 H); doublet, center, δ 3.70, $J_{ab} = 3.6$ Hz (1 H); singlet δ 3.09; AB pattern, centers, δ 2.74, δ 2.42, (2 H) $J_{ac} = 12$ Hz; singlet δ 0.41 (3 H); singlet δ -.21 (3 H).

IR 3080, 3060, 3020, 2980, 2960, 2940, 2830, 1600, 1580, 1495, 1445, 1260-1250, 1160, 1080, 1040, 870, 840, 790-780, 760, 700 cm⁻¹.

Mass Spectrum 70 eV 350-0.25%, 335-0.5%, 303-1.6%, 264-16%, 263-32%; high temperature inlet (200° C) 70 eV 262-100%; 20 eV 350-2.0%, 262-100%.

Photolysis of dimethyldiphenylsilole (1) in dimethoxyethylene (12) to give (13). A solution of 4.011 gm (1.53 x 10⁻² moles) and 250 ml 1,1-dimethoxyethylene was put into an

immersion well and degassed for 10 minutes with nitrogen. The sample was then capped and photolyzed with a 450 watt Hanovia medium pressure mercury arc lamp through a Pyrex immersion well condensor. After irradiation for 5 hours, the sample was isolated by removal of the dimethoxyethylene via vacuum distillation. An NMR showed the residue to be ca. 80% adduct. Chromatography on a 6 x 20 cm column of silica gel packed in hexane separated unreacted silole from the adduct. Elution with 10% ether/hexane removed the adduct. Evaporation of the solvent gave 4.01 gm of a 90% mixture of the adduct and the dimer. Complete separation could be obtained by rechromatography on silica gel.

Hydrolysis of Ketal (13) to give (14). A solution of 0.5221 gm (1.49×10^{-3} moles) adduct ketal, 50 ml reagent acetone, 5 ml water and 0.05 gm tosic acid was refluxed under nitrogen for 12 hours. After cooling the acetone was removed in vacuo, the resulting residue redissolved in 60 ml ethyl ether and washed with 20 ml 5% sodium bicarbonate solution and 30 ml saturated sodium chloride solution. The organic layer was dried with magnesium sulfate, the solution filtered and the solvent removed in vacuo to give 0.501 gm yellow oil.

NMR Aromatic multiplet δ 7.28 to 6.80; olefin doublet, center, δ 6.86, $J_{ax} = 4$ Hz (1 H); allyl octet δ 4.49, center,

$J_{ax} = 4$ Hz, $J_{ab} = 2$ Hz, $J_{ac} = 1$ Hz; octet center δ 3.61 and δ 3.35, $J_{cb} = 11$ Hz, $J_{ab} = 2$ Hz, $J_{ac} = 1$ Hz; singlet δ 0.40 (3 H); singlet δ -0.11 (3 H).

IR 3090, 3070, 3030, 2980, 2920, 1785, 1605, 1585, 1570, 1500, 1450, 1400, 1266, 1115, 1080, 930, 880, 800, 785, 760, 700 cm^{-1} .

Mass Spectrum 70 eV 304-78%, 289-30%, 262-100%, 230-65%, 20 eV 304-10%, 289-24%, 262-79%.

Reduction with lithium aluminum hydride of ketone (14).

The ketone, 0.525 gm (1.71×10^{-3} moles), in 30 ml dry THF was added dropwise to a stirred mixture of 0.1407 gm (3.71×10^{-3} moles) lithium aluminum hydride in 40 ml dry THF under nitrogen. After stirring at room temperature for 6 hours, the solution was worked up by adding 2 ml water dropwise and filtering the solution. After drying with magnesium sulfate, the solvent was removed in vacuo to give a light yellow oil. Chromatography on a 4.0 x 18 cm column of alumina packed in hexane separated the small amount of silole dimer present. Elution with 5% ether/hexane gave 0.3896 gm alcohol (15).

NMR Aromatic multiplet δ 7.24-6.77 (11 H); multiplets at δ 4.54-4.18, δ 3.90-3.27, δ 3.08-2.04; singlets δ 0.38 and δ -0.26 equal intensity; singlets δ 0.11 and δ -0.55 equal intensity (6 H total).

NMR Aromatic singlet δ 7.61; aromatic multiplet δ 7.47 to δ 7.30; aromatic singlet δ 7.18.

IR 3080, 3040, 1600, 1580, 1490, 1410, 1010, 846, 750, 690 cm^{-1} .

Mass Spectrum 70 eV 231-22.5%, 230-100%; 20 eV 231-21.2%, 230-100%.

UV λ max(\AA) in methylene chloride 2280 \AA (end absorption), 2810 \AA mp = 211.5° C (p-terphenyl), UV λ max 2810 \AA .

The mother liquor solvent was removed in vacuo to give 0.481 gm yellow oil whose spectral characteristics were identical to the following alternate workup product.

A solution of 5.50 gm (1.81×10^{-2} moles) 1-silabicycloheptenone (14) with 0.928 gm (2.50×10^{-2} moles) sodium borohydride in 700 ml dry THF was stirred overnight at room temperature and under nitrogen. 5 Ml water was then added and the reaction stirred for 1 hour. The solvent was then removed in vacuo and the residue extracted with (2 x 200 ml) ethyl ether and 100 ml water. The organic layers were combined, dried with magnesium sulfate and the solvent removed in vacuo to give a yellow oil. Chromatography on a 6.0 x 30 cm column of silica gel packed with hexane enabled separation. Elution with 5% ether/hexane removed 1.10 gm silole dimer. Elution with 50% ether/hexane gave 2.243 gm (52%) colorless oil (16).

NMR Aromatic multiplet δ 7.41 to δ 6.80 (22 H); quartet, center, δ 4.40 $J_{ab} = 8$ Hz ($1\frac{1}{2}$ H); multiplet δ 3.90, center, ($1\frac{1}{2}$ H); obscured doublet of triplets δ 3.80, center, $J_{ac} = 8$ Hz, $J_{ab} = 4.5$ Hz ($1\frac{1}{2}$ H); triplets δ 3.40, center, $J_{ab} = 4.5$ Hz ($\frac{1}{2}$ H); multiplet δ 2.90 to δ 2.28 (6 H goes to 4 H with D_2O); broad singlet δ 0.38; singlet δ -0.19; singlet δ -0.26 (12 H together).

IR 3600-3200, 3080, 3066, 3040, 2980, 2940, 1600, 1580, 1500, 1450, 1250, 1120-1080, 840, 780, 760, 700 cm^{-1} .

Mass Spectrum 70 eV 306-51%, 262-1005; 20 eV 306-11.5%, 262-100%.

Exact Mass calculated 306.1439 for $C_{20}H_{22}SiO$

Exact Mass found 306.1400

Preparation of the mesylate (18). To a solution of 60 ml dry (distilled from BaO) pyridine and 2.243 gm (7.34×10^{-3} moles) (16) was added 1.65 gm (1.47×10^{-2} moles) methane sulfonyl chloride (redistilled) at $0^\circ C$. Immediately after addition, crystals started to form. The solution of (18) was put in the freezer overnight then worked up. The contents of the flask were poured into 100 gm ice and 50 ml water. There was no precipitate; therefore, the mixture was extracted with ethyl ether (2 x 250 ml). The organic layer was washed twice with 100 ml portions of 1N HCl, then with 100 ml water and dried over magnesium sulfate and

and potassium carbonate. The solution was then filtered, the solvent removed in vacuo to give 2.2016 gm isolated product. An NMR was taken immediately. It showed an aromatic multiplet δ 7.57 to δ 6.58; multiplet, center, δ 6.39; doublet of triplets, center, δ 4.70; quartet, center, δ 3.84; singlet δ 2.84, (mesylate methyl); multiplets δ 3.20 to δ 3.92 and δ 2.70 to δ 2.46; singlet δ 0.47; broad singlet δ 0.14 and a singlet δ -0.20 (ratio 1:2:1 for SiMe signals). The NMR after 18 hours at -10° C was essentially the same. Purification of the mesylate was not done due to the supposed decomposition; instead, it was used directly in the next reaction.

Solvolysis of the mesylate (18). A portion (2.2016 gm (5.74×10^{-3} moles)) of the crude mesylate was dissolved in 100 ml reagent acetone. To this solution was then added 10 ml water and 0.2775 gm (4.61×10^{-3} moles) urea. The solution was then stirred at 52° C to 56° C for 36 hours. The acetone was then removed in vacuo and the heterogeneous residue redissolved in 150 ml ether. The water layer was separated and the organic layer washed with 30 ml water. The ether layer was separated, dried with magnesium sulfate, filtered; solvent removed in vacuo; carbon tetrachloride added and removed in vacuo and the sample dried with a vacuum to give 1.865 gm oil. The NMR of the crude reaction material

matched that of the crude starting material: silicon methyl region, singlet δ 0.42; broad singlet δ 0.12; singlet δ -0.22 (ratio 1:2:1).

Chromatography of the oil on a 6.5 x 36 cm column of silica gel packed in hexane afforded separation of three components. 1% Ether/hexane removed 0.1112 gm component A, component B had a lower R_f value in 1% ether/hexane and was also separable to give 0.2291 gm. 50% Ether/hexane removed component C, 0.7238 gm (33%).

Component A (19) (7%) NMR Aromatic multiplet δ 6.93 to δ 6.76 (10 H); doublet of doublets, center, δ 6.79 $J_{ab} = 2.8$ Hz, $J_{ab'} = 4.5$ Hz; doublet of doublets, center, δ 6.52, $J_{ba} = 2.8$ Hz, $J_{ba'} = 4.5$ Hz (4 H); singlet δ 0.092 (6 H).

UV λ_{max} ($\epsilon \times 10^{-4}$) methylene chloride 2175 Å (1.61), 2235 Å (1.46), 2465 Å (1.14), 3150 Å (0.566).

Exact Mass $C_{20}H_{20}Si^{28}$ calculated 288.1334

Exact Mass found 288.1342

Exact Mass $C_{20}H_{20}Si^{29}$ calculated 289.1330

Exact Mass found 289.1338

Exact Mass $C^{13}C_{19}H_{20}Si^{28}$ calculated 289.1368

Exact Mass found 289.1368

Mass Spectrum 70 eV 288-78.5%, 273-58.5%, 230-100%; 16 eV 288-100%, 273-21.5%, 230-52%, M^* at 260 for 288+273, M^* at 185 for 288+230.

Component B (20) (14%): this component was composed of more than one material. It was rechromatographed on a silica gel preparatory TLC plate with 3% ether/hexane and the fluorescent band removed to give 0.153 gm light yellow, solid material.

NMR Broad aromatic singlet δ 7.26; aromatic doublet at δ 7.17, δ 7.14; multiplet δ 6.60 to δ 6.28 (3 H); broad singlet δ 0.27 to δ 0.17 (6 H).

UV λ_{\max} (no ϵ) 2500 Å, 3230 Å, 3310 Å, 3390 Å.

IR 3070, 3060, 2980, 1680, 1500, 1454, 1260, 842, 786, 760, 708 cm^{-1} .

Mass Spectrum 70 eV 288-13.5%, 262-54%, 230-100%; 16 eV 288-19%, 262-19%, 232-50%, 230-100%.

Component C (18-1) (33%) NMR Aromatic multiplet δ 7.38 to δ 6.80 (11 H); doublet of triplets, center, δ 4.62, $J_{ac} = 7.5$ Hz, $J_{ab} = 5$ Hz (1 H); broadened triplet, center, δ 3.83, $J_{ba} = 5$ Hz (1 H); multiplet δ 3.07 to δ 2.36, with a singlet δ 2.88 (5 H); singlet δ 0.47 (3 H); and singlet δ -0.21 (3 H).

IR 3060, 3040, 2970, 1603, 1585, 1500, 1450, 1416, 1380-1330, 1260, 1190-1170, 1095, 1080, 1040, 1015, 1000, 975-960, 940, 900-870, 850, 820, 800-770, 705 cm^{-1} .

Mass Spectrum 70 eV 353-4.6%, 305-7.4%, 230-100%.

The p-Nitrobenzoate (17). A 1.0945 gm (3.58×10^{-3} moles) sample of the alcohol, prepared and purified in the usual manner, was added to 1.371 gm (7.1×10^{-3} moles)

recrystallized p-nitrobenzoylchloride in 30.0 ml freshly opened pyridine. The reaction mixture was kept at -10° C for 36 hours. During this time the pyridine hydrochloride separated from the reaction mixture. The reaction was worked up by pouring the mixture into 60 gm ice with resultant separation of a solid. The aqueous solution was filtered; the solid dissolved in methylene chloride, washed with 30 ml water and separated and the organic layer dried with magnesium sulfate. Charcoal (0.2 gm) was added, the solution filtered and solvent removed in vacuo to give a solid residue. This residue was taken up with methylene chloride, evaporated to a minimum amount and hexane added to give 0.226 gm p-nitrobenzoic acid. The mother liquor was concentrated and chromatographed on a 6 x 6 cm column of silica gel packed with hexane. After washing with 500 ml of hexane, which removed nothing, the column was eluted with 30% ether/hexane to give 0.88 gm light yellow oil.

NMR Aromatic singlet δ 8.08 (8 H); aromatic olefinic multiplet δ 7.44 to δ 6.80 (22 H); quartet, center, δ 5.48 $J_{ab} = 8$ Hz (1 H); doublet of triplets, center δ 4.86 $J_{ab} = 7$ Hz, $J_{ab} = 4.8$ Hz (1 H); doublet of doublets, center, δ 4.21, $J_{bx} = 3$ Hz, $J_{ba} = 8$ Hz (1 H); triplet, center, δ 3.75, $J_{bx} = 4.8$ Hz = J_{ba} (1 H); multiplet δ 3.18 to δ 2.44 (2 H); singlets at δ 6.50, δ 0.44, δ -6.14, δ -0.20 with the inner and outer peaks paired.

IR 3080, 3060, 3040, 2960, 1735, 1610, 1545 to 1535, 1500, 1450, 1365 to 1355, 1295 to 1250, 1130 to 1100, 1020, 900, 880, 850, 790, 760, 725, 700 cm^{-1} .

Mass Spectrum 70 eV 455 unobservable, 305-0.12%, 262-100%, 16 eV 455-2%, 305-4%, 289-11%, 262-100%, 230-80%.

Solvolysis of the unreacted mesylate (18-1) in alcohol.

A 0.580 gm (1.51×10^{-3} moles) sample of the unreactive mesylate was solvolyzed in 200 ml 80% aqueous ethanol with 0.40 gm urea as a base at 55° to 60° C for three days. The reaction mixture was cooled, allowed to stand for a few hours and then worked up. The ethanol was removed in vacuo and the residue extracted with 200 ml methylene chloride and 50 ml water. The organic layer was separated, dried with magnesium sulfate, filtered and the solvent removed in vacuo to give an oil. The oil was dried by vacuum evaporation and an NMR taken. It was identical to the starting substrate (18-1) NMR.

Thermolysis of 20. A solution of 0.13 gm (6.92×10^{-4} moles) in carbon tetrachloride was heated at reflux for three days. The solvent was then removed and the residue dried. The NMR showed no change from that of the starting substrate 20.

Solvolysis of 17-1 and 17-2 (endo and exo respectively).

A solution of 0.886 gm (1.93×10^{-3} moles) of the mixture of 17 in 80% aqueous acetone with excess urea was heated at reflux for 10 days. Workup by removal of the acetone in vacuo, extraction with methylene chloride/water, drying with $MgSO_4$, filtering and drying gave a yellow oily solid. The NMR of this solid showed no change from the mixture of 17.

The sample was redissolved in 150 ml 90% aqueous ethanol and excess urea. It was then heated at reflux for 5 days. Workup in the same manner gave a light yellow solid. The NMR of the mixture showed the presence of 17-2 (exo) and 19 in about a 1 to 1 ratio.

Synthesis of dichlorovinylene carbonate. A procedure similar to that of Ellingboe and Melby, Ref. 213, used to prepare tetrachlorethylene carbonate was employed here. bp_{42torr} 65-68° C (lit. bp_{42torr} 65-66° C)
UV in CCl_4 λ_{max} 2530 Å, 2570 Å, tailing to 2700 Å.

Photolysis of dimethyldiphenylsilole (1) and dichlorovinylene carbonate. A solution of 2.64 gm (1.02×10^{-2} moles) dimethyldiphenylsilole and 39.5 gm (2.55×10^{-1} moles) dichlorovinylene carbonate was put in a Pyrex tube and degassed with nitrogen for 1 hour. The tube was then capped

and photolyzed at 3000 Å in a Rayonet photoreactor for 2 days. Periodic monitoring by NMR showed the gradual disappearance of silole. The excess carbonate was removed by vacuum distillation and the dark residue chromatographed on a 6 x 9 cm column of silica gel packed in hexane. Elution with 5% ether/hexane gave 2.32 gm white solid, mp 195-198° C. NMR identified it as the silole dimer (2)

Photolysis of 1,1,3-trimethyl-1-silacyclopent-3-ene (24)
with various photophiles. The following four solutions were put into four separate Pyrex NMR tubes:

1. 0.34 ml (24) and 0.68 ml dimethylacetylene-dicarboxylate
2. 0.34 ml (24) and 0.68 ml phenylacetylene
3. 0.34 ml (24) and 0.68 ml dichlorovinylencarbonate
4. 0.34 ml (24)

The solutions were degassed with nitrogen, capped and photolyzed at 3000 Å in a Rayonet photoreactor. The samples were periodically monitored by NMR. Samples 1, 2 and 4 showed no change during a photolysis time of 2 days. Sample 4 was removed and 2 ml of reagent acetone added; the sample degassed and photolysis again initiated. After an additional 2 days, samples 1, 2, and 4 still showed no change. Solution 3, however, showed two silicon methyl resonances indicating a preparation scale reaction might have merit.

Photolysis of 1,1,3-trimethyl-1-silacyclopent-3-ene (24)

with maleic anhydride at 3000 Å in acetone. A solution of 4.0 gm (31.7 mmoles) (24), 1.50 gm (15.3 mmoles) maleic anhydride, 25 ml acetone and 0.4 gm benzophenone was photolyzed under nitrogen with a 450 watt medium pressure mercury arc lamp through a Pyrex immersion well. After irradiation for 48 hours, the dark brown solution was removed from the irradiation vessel. The solvent then was removed in vacuo to give a brown oil. Dissolution of the oil in ethyl ether was followed by extraction with 2 x 75 ml saturated sodium carbonate solution. The basic aqueous layer was acidified to give a small amount of solid product (B). An oil separated from the concentrated organic layer and was found to be soluble in water. The organic layer and oil were washed with water (2 x 50 ml). Acidification of this aqueous layer caused separation of a yellow oil. Extraction of the oil and water with methylene chloride (2 x 60 ml) followed by drying the combined organic extracts with magnesium sulfate, filtration, removing the solvent in vacuo gave a yellow solid, 1.256 gm, mp 105-138° C.

NMR Broad absorption δ 1.60, δ 0.90; broad absorption δ 0.18 to δ 0.10.

IR 3500-3100, 3000, 1710, 1370, 1250, 1080-1030, 830, 790.

Mass Spectrum 70 eV 280-100%, 281-7.55%, 282-4.3%.

Recrystallization of the small solid product (B) from the methylene chloride gave 0.0918 gm of white crystals, mp 280° C. Compound identified as cis, trans, cis-cyclobutanetetracarboxylic acid.

Photolysis of 1,1,3-trimethyl-1-silacyclopent-3-ene (24) with dichlorovinylene carbonate. A mixture of 4.80 gm (3.8×10^{-2} moles) 24 and 8.5 gm (5.5×10^{-2} moles) dichlorovinylene carbonate was put in a 25 ml Pyrex flask, degassed with nitrogen for 15 minutes and then sealed. It was then photolyzed at 3000 Å in a Rayonet photoreactor for 3 days. An aliquot was then removed and an NMR taken. It showed no change from starting material. 10 ml reagent acetone was added and the photolysis at 3000 Å continued. After 1 day no change was revealed in the NMR. 20 ml reagent acetone was then added, the sample container changed to quartz tube and irradiation continued at 3000 Å. Periodic monitoring by NMR showed the gradual build-up of two new peaks, hump δ 4.55 to δ 4.79, and a singlet δ 0.17.

After irradiation for four days, the mixture was given an acid work-up. The solvent was removed in vacuo, the residue redissolved in methanol; 70 ml 2N HCl solution added and the mixture stirred for 24 hours. The methanol was then removed in vacuo and the heterogeneous mixture extracted with (2 x 150 ml) methylene chloride. The organic

layers were combined and washed with a saturated sodium bicarbonate solution, dried with magnesium sulfate, filtered and after the solvent was removed by vacuum, an oil resulted having a carbonyl absorption at 1710 to 1760 cm^{-1} but no carbonate or SiO absorptions. The material was chromatographed on a 6.5 x 15 cm column of silica gel packed in hexane. Elution with hexane removed fraction 1-2.55 gm. Elution with 10% ether/hexane removed fraction 2-1.2 gm. Elution with 40% chloroform/hexane removed fraction 3-2.4 gm and chloroform removed fraction 4-2.6 gm. Fraction 1 NMR singlet δ 3.80; complex absorption δ 1.40-0.9; hump δ 0.10.

IR (salt plates) 2970, 2920, 1780, 1440, 1250, 1130, 1030, 850 cm^{-1} .

Fraction 4 NMR multiplet δ 4.90 broad; singlet δ 3.80; singlet δ 2.20; triplet δ 1.30; doublet δ 1.10.

IR (salt plates) 3600-3200, 2980, 1760, 1450, 1260, 1100-1030, 850, 800 cm^{-1} .

Mass Spectrum 70 eV 356-1.8%, 352-4.6%, 344-4.6%, 280-10%, 279-23%, 278-34%, 235-19%, 222-27%, 207-100%.

Photolysis of 1,1-dimethoxyethylene (12) with trimethyl-1-silacyclopent-3-ene (24). A 2.72 gm (3.1×10^{-2} moles) sample of 1,1-dimethoxyethylene prepared by the method of Corey, Bass, LeMahieu and Mitra, Ref. 156, was added to 3.91 gm

1,1,3-trimethyl-1-silacyclopent-3-ene and 10 drops acetophenone in a quartz photolysis tube. The sample was degassed with nitrogen for 5 minutes, capped and photolyzed at 3000 Å in a Rayonet photochemical reactor for 10 hours. An NMR check of the solution showed no reaction. The lamps were changed to 2537 Å lamp (PhCOCH_3 , λ_{max} 2600 Å) and irradiation continued for 2 days. The NMR showed no change. 20 Ml reagent acetone was added and photolysis continued for another day. Removal solvent in vacuo gave 3.61 gm trimethylsilacyclopent-3-ene (92% recovery).

Photolysis of trimethyl-1-silacyclopent-3-ene (24) with maleic anhydride at 2537 Å. A mixture of 12.829 gm (1.02×10^{-1} moles) 24 and 0.9207 gm (9.4×10^{-3} moles) maleic anhydride was put in a quartz photolysis tube and degassed for 15 minutes. The mixture was then photolyzed in a Rayonet photochemical reactor at 2537 Å for 8 hours. The irradiated liquid was then poured out of the tube and the solid residue dissolved in acetone. The excess trimethylsilacyclopentene was removed from the liquid phase by vacuum distillation to give an oily solid residue. This residue was dried and an NMR taken showing a broadened singlet δ 0.31 to δ 0.29. The acetone was removed in vacuo from the solid phase. It was dried by vacuum evaporation and an NMR taken. The resulting NMR was singlet δ 7.10 (maleic anhydride); singlet δ 2.48 (1 H); singlet δ 2.42 (1 H); broad singlet δ 1.83 (3 H); broad singlet δ 1.67 (1 H).

After standing the solid sample crystallized into two parts:
 A, white crystals with a mp 53.5-54.5° C, the maleic
 anhydride; B, off-white to brown crystals with a mp 108-
 112° C, 0.7350 gm. Its (B) mass spectrum was taken.
 Mass Spectrum 70 eV 356-6.6%, 284-50%, 283-100%, 207-9.5%,
 20 eV 356-100%, 283-43%.

Reaction of 1,1-dimethyl-2,5-diphenylsilole (1) with
 maleic anhydride to give (25). A solution of 1.310 gm
 (5.00 mmoles) 1,1-dimethyl-2,5-diphenylsilole, 0.480 gm
 (5.00 mmoles) maleic anhydride and 15 ml dry benzene was
 heated at just below reflux for several minutes in an
 Erlenmeyer flask. The solution was then cooled resulting
 in crystallization of a white powdery product. Filtration
 gave 1.800 gm (100%). Recrystallization from ethyl ether/
 hexane gave 1.750 gm, white crystalline product, mp 180-186°C.
 Analysis calculated C-73.301, H-5.592, Si-7.791;
 (C₂₂H₂₀SiO₃)
 Analysis found C-73.33, H-5.58, Si-7.92
 NMR Aromatic singlet δ 7.31 (10 H); singlet δ 6.60 (2 H);
 singlet δ 4.37 (2 H); singlet δ 0.16 (3 H); singlet δ 0.10
 (3 H).
 IR 3000, 1850, 1770, 1605, 1500, 1440, 1115, 1245, 1210,
 1075, 1050, 935, 915, 840, 790, 745, 690 cm⁻¹.

Conversion of 7,7-dimethyl-1,4-diphenyl-2,3-dicarboxy-7-silanorborn-5-ene anhydride (25) to the dimethyl ester. A solution of 0.4276 gm (1.19 mmoles) adduct (25) in 20 ml absolute methanol was refluxed overnight with a catalytic amount of tosic acid. Toluene was then added and the azeotrope distilled (64° C) until the temperature dropped. 15 ml absolute methanol and 15 ml toluene were added and the solution refluxed for 2 days using a Dean Stark trap. The solvent was then removed in vacuo leaving a light colored crystalline material. This material was redissolved in methylene chloride, extracted twice with 10 ml water, dried over magnesium sulfate, the methylene chloride removed in vacuo and the residue recrystallized from methylene chloride/methanol to give 0.4520 gm crystalline material, mp 179-180° C.

NMR Pair of singlets δ 7.185 and δ 7.16 (5 H); olefin, broadened singlet δ 6.59 (1 H); singlet δ 4.30 (1 H); singlet δ 3.30 (3 H); singlet δ 0.50 (3 H).

IR 3000, 2960, 1740-1700, 1600, 1500, 1430, 1310, 1230-1200, 1160, 1020, 620, 870, 130, 790, 750, 690 cm^{-1} .

Mass Spectrum 70 eV 406-4%, 391-2%, 262-100%; 16 eV 406-10%, 262-100%.

Reaction of 1,1-dimethyl-2,5-diphenylsilole (1) with dimethylacetylene dicarboxylate. A 1.182 gm (10.7 mmoles)

sample of dimethylacetylene dicarboxylate in 10 ml of dry toluene was added dropwise to a stirred refluxing solution of 50 ml dry toluene and 2.010 gm (7.68 mmoles) of 1,1-dimethyl-2,5-diphenylsilole. After addition was complete the reaction was refluxed 3 hours then cooled. The resulting precipitate was filtered to give 2.123 gm, white powder, mp 189° C. This product is identical with p-terphenyl-2,3-dicarboxymethylester (literature melting point 189° C).

Reaction of 1,1-dimethyl-2,5-diphenylgermole (4) with maleic anhydride to give (26). A solution of 0.2673 gm (0.870 mmoles) 1,1-dimethyl-2,5-diphenylgermole in 30 ml acetone was put in a flask. To this stirred solution was then added 0.0860 gm (0.870 mmoles) maleic anhydride in 10 ml acetone dropwise. After addition was complete, the reaction mixture was refluxed for 3 hours. The solution was worked up by removing the solvent in vacuo, dissolving the oily residue in methylene chloride and recrystallizing it from ethyl ether and hexane. Crystallization gave 0.3220 gm (91%), white powdery crystals, mp 179-181° C.

NMR Aromatic singlet δ 7.32 (10 H); singlet δ 6.65 (2 H); singlet δ 4.51 (2 H); singlet δ 0.40 (3 H); singlet δ 0.32 (3 H).

IR 3060, 1860, 1790-1775, 1605, 1505, 1450, 1256, 1230, 1088, 1058, 942, 929, 758, 706, 670 cm^{-1} .

Mass Spectrum 406-3%, 346-6%, 344-7%, 342-6%, 308-100%,
306-72%, 304-56%.

Reaction of 1,1-dimethyl-2,5-diphenylgermole (4) with dimethylacetylene dicarboxylate. A solution of 0.307 gm (1 mmole) dimethyldiphenylgermole and 0.142 gm (1 mmole) dimethylacetylene dicarboxylate in 5 ml ethyl ether was mixed under nitrogen at 0° C. The solution was stirred at 0° C for 3 hours and then warmed to room temperature. Five more ml of ethyl ether was added along with 3 ml hexane. The solution was cooled to give 0.13 gm, white powder, mp = 189° C (phthlate).

Reaction of 1,1-dimethyl-2,5-diphenylstannole (5) with maleic anhydride. A solution of 0.3584 gm (0.0098 moles) 1,1-dimethyl-2,5-diphenylstannole, 0.1055 gm (90,0107 moles) maleic anhydride in 25 ml dry benzene was refluxed for 1 hour. The reaction mixture was stirred overnight at room temperature, then worked up. The solvent was removed in vacuo and the residue crystallized from methylene chloride giving 0.1733 gm, off-white powder, recrystallization from benzene gave 0.100 gm, white powder, mp 258-260° C with evolution of gas.

Mass Spectrum m+ region 448-20%, 450-30%, 452-50%.

IR 3060, 3040, 2940, 1600 broad, 1500, 1450, 1410-1390,
1300, 1260, 1210, 850, 790, 760, 700 cm⁻¹.

Reaction of 2,5-diphenyltellurophene (10) with benzyne.

A solution of 0.9883 gm (2.99 mmoles) 2,5-diphenyltellurophene, 0.550 gm (2.99 mmoles) benzenediazonium-2-carboxylate hydrochloride, 40 ml 1,2-dichloroethane and 0.404 ml propylene oxide was put in a flask and refluxed in a steam bath for 2 hours. The reaction mixture was then cooled and the precipitated tellurophene filtered. The solvent was removed in vacuo, the residue dissolved in methylene chloride, and the solution percolated through a 6x6 cm column of silica gel packed in hexane. Eluting with hexane removed a compound whose NMR was identical with the starting tellurophene. This residue and the filtered tellurophene were combined and crystallized from ethyl ether/hexane to give 0.91 gm, mp 222-224° C.

Reaction of 2,5-diphenyltellurophene (10) with maleic anhydride and with dimethylacetylene dicarboxylate. A 0.500 gm (1.51 mmoles) sample of 2,5-diphenyltellurophene was put into 2 ml deuteriochloroform. This sample was split into two portions 1 ml each and put into two NMR tubes. Into tube 1 was then put 1.00 gm (10.2 mmoles) maleic anhydride and the tube capped. Into tube 2 was then put 1.00 gm (7.05 mmoles) dimethylacetylene dicarboxylate. NMR's of the samples were then taken showing unreacted starting material. The samples were heated at 50° C in an oil

bath for 3 days. The NMR's of both samples were identical to those taken before heating.

Addition of dimethyldiphenylsilole (1) to dichlorovinylene carbonate in benzene. A solution of 1.00 gm (3.82×10^{-3} moles) dimethyldiphenylsilole, 0.542 gm (3.82×10^{-3} moles) dichlorovinylene carbonate and 25 ml benzene was heated to reflux for 5 minutes. The solution was then cooled, the benzene removed and the residue crystallized from hexane to give 0.860 gm recovered silole (86%) by NMR identification.

Diels-Alder reaction in toluene of the silole (1) and dichlorovinylene carbonate. A solution of 2.01 gm (7.65×10^{-3} moles) dimethyldiphenylsilole and 1.19 gm (1.70×10^{-3} moles) dichlorovinylene carbonate in 1.50 ml dry toluene (dried with sodium) was refluxed for 9 hours. After standing overnight at room temperature, the solvent was removed by vacuum distillation. The residue was dried by vacuum evaporation and an NMR taken. The NMR was identical to that of silole. Crystallization from hexane gave 1.80 gm silole, mp 130-133° C.

Diels-Alder reaction without toluene (neat) at 150-156° C. A solution of 16.0 ml dichlorovinylene

carbonate and 1.251 gm (4.8×10^{-3} moles) dimethyldiphenylsilole (1) was put in a sealed tube; the tube evacuated, flushed with nitrogen, evacuated, and then sealed while keeping the mixture at -78° C. The tube was then heated in an oil bath at $150-156^{\circ}$ C for 12 hours. The reaction solution was cooled, the sealed tube opened and the excess dichlorovinylene carbonate removed by vacuum distillation. The solid residue was chromatographed on a 6 x 20 cm column of silica gel packed in hexane. Elution with 10% ether/hexane gave 0.9376 gm, white crystalline product, mp $142-143^{\circ}$ C.

NMR singlet δ 5.82 (1 H); aromatic singlet δ 6.90; broad singlet δ 7.09; aromatic multiplet δ 7.20-7.50 (total 12 H).

IR 3500 (sharp and strong), 3080, 3060, 3040, 1610, 1580, 1556, 1480, 1450, 1410, 1300, 1250, 1200, 1140, 1075, 1050, 1020, 900, 820, 760, 700, 650 cm^{-1} .

Mass Spectrum 292-34.2%, 280-100%, 246-22%, 244-9%;
16 eV 282-33%, 280-100%, 246-14%.

Analysis calculated C-77.00, H-4.67; ($\text{C}_{18}\text{H}_{13}\text{ClO}$)

Analysis found C-77.12, H-4.81

NMR prior to chromatography singlet δ 0.25; singlet δ 6.98; singlet δ 7.03; aromatic multiplet δ 7.12-7.40.

Diels-Alder reaction at 150° C of the silole (1) and carbonate to give (28). A solution of 0.6612 gm (2.52 x 10⁻³ moles) dimethyldiphenylsilole (1) and 5.0 ml dichlorovinylene carbonate was heated at 150° C for 3.5 hours in a flask equipped with a condensor and drierite tube. The sample was then cooled and the excess dichlorovinylene carbonate removed by vacuum distillation. The resulting oil was recrystallized from methylene chloride/hexane to give 0.4214 gm, white crystalline solid, dec = 153° C (explodes).

NMR Aromatic singlet δ 7.32 (12 H); olefin singlet δ 6.42 (2 H); singlet δ 1.01 (3 H); singlet δ 0.49 (3 H).

IR (KBr pellet) 3060, 3040, 3030, 1860-1810, 1580, 1500, 1450, 1265, 1230-1220, 1100, 1080, 1055-1030, 970, 930, 880, 810, 760, 710 cm⁻¹.

Mass Spectrum 383-2.66%, 381-6.66%, 376-20%, 374-20%, 374-76%, 372-100%; 70 eV 359-20%, 357-26.6%, 288-26%, 262-6%, m* 343-341 (372-357 calculated 341).

Analysis calculated C-60.43, H-4.35; (C₂₁H₁₈O₃SiCl₂)

Analysis found C-60.04, H-4.21

Solid decomposition of 1,4-diphenyl-2,3-dichloro-7,7-dimethyl-7-silanorborn-5-ene-2,3-carbonate (28). A solid 97 mg sample of the adduct (28) was put in a vacuum line tube and evacuated to 10⁻¹ torr. The sample was connected

by means of the vacuum line to a gas collection bulb which was cooled to 76° K. The adduct was then slowly warmed to 153° C, upon reaching that temperature the sample exploded producing a green glass. After the gas collection bulb was warmed to room temperature, it was reweighed. Its weight had only increased by 2.0 mg.

NMR (green glass) aromatic singlet δ 7.30; aromatic singlet δ 7.26; olefin singlet δ 6.32; singlets δ 0.95, δ 0.43 of equal intensity; singlet δ 0.23 (TMS = 0.07).

IR 3080, 3040, 2980, 2920, 1860-1820, 1760, 1610, 1580, 1540, 1500, 1470, 1450, 1410-1400, 1320, 1270, 1230, 1110, 1080, 1050, 970-950, 930 cm^{-1} .

NMR pyrolysis study of the silole adduct (28).

A solution of 96 mg of the adduct (28) was put in 2 ml tetrachloroethane, degassed, evacuated and sealed in a heavy walled NMR tube. The sample was slowly warmed in the NMR probe to 155° C over a period of 30 minutes. There was no detectable change in the NMR. The sample was then heated in an oil bath at 148-150° C for 4.5 hours. The NMR indicated no change. The bath temperature was then increased to 165° C where decomposition occurred slowly over 10 hours.

NMR (10 hours) aromatic singlet δ 7.32; aromatic singlet δ 7.27; multiplet δ 7.02-6.98; singlet δ 6.39; singlets δ 0.98 and δ 0.48, equal intensity; singlet δ 0.28 (20 H) (reference was tetrachloroethane 5.87).

Chromatography on a 3.5 x 29 cm column of silica gel packed in hexane gave 50 mg chlorodiphenylphenol.

The experimental procedures for the synthesis and reactions of compounds 30 through 40 may be found in Ref. 165.

The experimental procedures for the synthesis and reactions of compounds 42 through 53 may be found in Ref. 192.

Synthesis of 1,8-bis(phenylethynyl)naphthalene (56).

The procedure of Ipadtschi and Stabb, Ref. 193, was followed. mp 98-101° C (lit. mp 100-101° C)

Synthesis of 1,8-distyrylnaphthalene. A modified procedure of Bergmann and Agranat, Ref. 211, was used. A 50.0 gm sample of naphthalic anhydride in ca. 100 ml toluene previously distilled from calcium hydride was added as a slurry dropwise to a stirred, refluxing solution of 500 ml dry toluene and 150 ml 75% Vitride in benzene. After 1.5 hours, addition was complete and the resulting dark brown solution homogeneous. The reaction was refluxed 30 minutes more, cooled, and allowed to stand at room temperature for 3 hours. Then 1 liter of

20% (dilute 1:4) sulfuric acid was added. Upon addition, a solid formed. After standing overnight, the solid was filtered and recrystallized from absolute ethanol to give 32.0 gm of the diol, mp 153-155° C (lit. 155° C).

1,8-bis(bromomethyl)naphthalene. The method of Mitchell, Topson, Vaughan, Ref. 212, was used to prepare the compound. mp 128-130° C (lit. mp 129-130° C)

Reaction of 1,8-bis(phenylethynyl)naphthalene (56) with sulfur dichloride to give (60) and (61). A solution of 1.868 gm (5.70 mmoles) 1,8-bis(phenylethynyl)naphthalene and 450 ml dry (percolated through alumina and stored over 4 Å molecular sieves) methylene chloride and a solution of 0.800 gm (7.79 mmoles) sulfur dichloride in 450 ml dry methylene chloride were added dropwise simultaneously to a stirred-kept-in-the-dark--1.3 l. portion of dry methylene chloride at room temperature. After addition was complete, ca. 2.5 hours, the reaction mixture was refluxed gently for 2 hours more. At all times the reaction flask was kept covered with aluminum foil to exclude light. Removal of solvent in vacuo, taking care to keep the flask covered, gave a dark, foul-smelling residue. The residue was chromatographed on a 6.5 x 70.0 cm column of silica gel packed with hexane. Elution with hexane gave two close bands on the column.

Collection of 40 ml fractions allowed the separation of these bands. The first red band fractions were combined, the solvent evaporated and residue recrystallized from ethyl ether to give 0.901 gm dark red crystalline material, mp 215.5-216.5° C (60). The second light yellow band fractions were collected to give 9.565 gm off-white needles after crystallization from methylene chloride and methanol, mp 200-201° C (61).

60's spectral data:

Exact Mass analysis (C₂₆H₁₄Cl₂) 396.0480-100%

(calculated 396.0472), 398.0406-64.58%, 400.0435-12.63%;

(C₂₆H₁₃Cl) 360.0724-11.23% (calculated 360.0706);

(C₂₆H₁₄) 326.1110-17.68% (calculated 326.1095).

IR 1615, 1587, 1570, 1485, 1440, 1360, 1335, 1128, 840, 782, 773, 767, 714, 702 cm⁻¹.

NMR Aromatic multiplet δ 8.35 to δ 8.17; singlet δ 8.10; singlet δ 7.97; doublet, center, δ 7.50; broad singlet δ 7.36 to δ 7.29; multiplet δ 7.20 to δ 6.92.

UV λ_{max} (ε x 10⁻⁴) 2095 Å (7.25), 2650 Å (6.55), 3300 Å (1.81), 3485 Å (2.05).

Visible Spectrum max (ε x 10⁻⁴) 4010 Å (1.06), 4210 Å (1.30), 4445 Å (1.18), 5150 Å (1.25), 5450 Å (1.02).

Analysis calculated C-78.20, H-4.04, Cl-17.76; (C₂₆H₁₄Cl₂)

Analysis found C-77.35, H-3.87, Cl-16.59

61's spectral data:

Analysis calculated C-72.39, H-3.74,

Cl-16.44; (C₂₆H₁₆SCl₂)

Analysis found C-72.33, H-3.67,

Cl-16.00

NMR doublet δ 8.20, center, J = 2 Hz; doublet δ 8.08, J = 2 Hz; multiplet δ 7.79 to δ 7.59; multiplet δ 7.49 to δ 7.14; singlet δ 6.97; multiplet δ 6.85 to δ 6.50.

Reaction of compound (60) (C₂₆H₁₄Cl₂) with maleic anhydride. A solution of 30 mg of crude (60) in 2 ml diglyme was heated to reflux with no apparent color change. The solution maintained its deep red appearance. Excess powdered maleic anhydride was then added and the solution refluxed for 20 minutes. Still there was no color change. The solution was then heated at reflux for 2 weeks. A solid had formed which was filtered and proved to be maleic anhydride, mp 54° C. The solution was still the characteristic red color. The solution was percolated through a $\frac{1}{2}$ x 1 cm column of silica gel packed in hexane. Removal of solvent in vacuo and crystallization from hexane/ether gave 15 mg deep red crystals, mp 214-216° C (starting material).

Ozonolysis of C₂₆H₁₆SCl₂ (61). A solution of 59 mg (1.38 x 10⁻¹ moles) compound (61) was put in a solution

of 100 ml carbon tetrachloride and 100 ml methylene chloride. The solution was then ozonized for 5 minutes at 0° C with an ozone/oxygen mixture giving 0.501 gm/hour of ozone. Workup was accomplished by addition of 5.0 ml H₂O. After separating the organic layer, the solvent was removed in vacuo resulting in a light brown residue. Recrystallization was attempted from acetone; however, the residue was not soluble. The residue was filtered and dried to give 12 mg solid, mp 265-269° C identical to naphthoic anhydride, mp 267-268° C (authentic sample).

Oxidation of C₂₆H₁₄Cl₂ (60) with chromium trioxide in acetic acid. A solution of 50.0 mg (5×10^{-4} moles) chromium trioxide in 5.0 ml water and 5.0 ml glacial acetic acid was added to a stirred mixture of 10.0 ml glacial acetic acid, 5.0 ml water and 54.7 mg (1.38×10^{-4} moles) (60) at room temperature. After addition of the chromium trioxide solution, the organic material dissolved in about 15 minutes. After stirring overnight at room temperature, a yellow solid had formed. 25.0 ml water was added to the reaction mixture, the mixture cooled, and the precipitate filtered and washed with water. It was redissolved in methylene chloride; the solvent evaporated to a minimum volume; a few drops of methanol added and the sample cooled to give 0.0391 gm yellow solid, mp 206-207° C.

IR (KBr) 2.80-3.00, 6.05, 6.15, 6.40, 7.20, 7.75, 7.80, 8.85, 10.75, 12.75, 14.30 μ .

A 5.0 mg of the product was dissolved in ethanol/methylene chloride, 2.4-DNP reagent added, the sample refluxed for a few minutes, cooled and filtered to give a dark yellow solid. The IR was identical to that of the oxidation product.

Exact Mass Spectrum (Battelle Memorial Institute)

Exact Mass	% Intensity	Calculated Mass	Compound
432.0474	0.20	432.0313	$C_{26}H_{14}O_2Cl_2^{37}$
430.0342	0.34	430.0342	$C_{26}H_{14}O_2Cl^{35}Cl^{37}$
428.0401	0.66	428.0371	$C_{26}H_{14}O_2Cl_2^{35}$
395.0692	37.68	395.0664	$C_{26}H_{14}O_2Cl^{37}$
393.0693	100.00	393.0682	$C_{26}H_{14}O_2Cl^{35}$

Attempted hydrogenation of $C_{26}H_{14}Cl_2$ (60). A solution of 93.9 mg (2.37×10^{-4} moles) $C_{26}H_{14}Cl_2$ in 80 ml ethyl acetate and 25 mg 10% Pd on charcoal was stirred at room temperature under H_2 at atmospheric pressure for 2 days. The reaction mixture was then filtered, solvent removed in vacuo and the product crystallized from hexane to give red needles (64 mg), mp 216-217° C (starting material). There was no uptake of hydrogen during the 2 days.

Reaction of $C_{26}H_{14}Cl_2$ (60) with diironnonacarbonyl. To a stirred mixture of 0.5677 gm (1.56×10^{-3} moles) diiron nonacarbonyl and 70 ml hexane was added 74.3 mg (1.88×10^{-4} moles) $C_{26}H_{14}Cl_2$ as a solid. The solution was then warmed to $60^\circ C$ and kept there overnight. The solution was then percolated through a 6 x 6 cm column of silica gel with hexane to remove the excess diiron nonacarbonyl. The solvent was removed in vacuo and the residue recrystallized from methylene chloride/hexane to give 58.7 mg, mp $215-217^\circ C$ (starting material).

Reaction of $C_{26}H_{14}Cl_2$ (60) with sodium in liquid ammonia. To a stirred portion of 150 ml liquid ammonia and 0.6 gm (2.6×10^{-2} moles) sodium at Dry Ice temperature was added 58.7 mg (1.48×10^{-4} moles) $C_{26}H_{14}Cl_2$ in 10 ml ethyl ether. After stirring for 4 hours and allowing the ammonia solution to come to room temperature, 20 ml reagent methanol was added. 100 ml ethyl ether was then added and the organic solution washed with 2 x 50 ml ammonium chloride solution. The aqueous layer was washed once with 50 ml ethyl ether, the organic layers combined and dried over magnesium sulfate. Filtration, followed by removal of solvent in vacuo, gave a red powdery residue 50.0 mg which sublimed at $172-180^\circ C$. Chromatography on a 2 x 60 cm column of silica gel packed in hexane gave three fractions.

Fraction A eluted with hexane; fraction B eluted with 8% ethyl ether/hexane; fraction C eluted with 20% ethyl ether/hexane. Fraction A-30.0 mg, fraction B-10 mg, and fraction C-4 mg were isolated.

NMR Fraction A singlet δ 7.70; singlet δ 7.47; aromatic multiplet δ 7.30-7.00.

IR 3080, 3040, 1650, 1600, 1590, 1500, 1460-1440, 1346, 1300, 1220, 1180, 1080, 1030 cm^{-1} .

Mass Spectrum 70 and 20 eV 328-80%, 330-100%, 332-80%; TLC, silica gel, hexane elution, shows two paired spots.

Reaction of $\text{C}_{26}\text{H}_{14}\text{Cl}_2$ (60) with methyl lithium. 0.2 ml of a 5.1% solution of methyl lithium in hexane was added via syringe and septum to a stirred solution of 20.5 mg (5.04×10^{-5} moles) $\text{C}_{26}\text{H}_{14}\text{Cl}_2$ in 30 ml dry THF at 0°C and under nitrogen. Immediately after addition of the methyl lithium, the color of the solution changed from blood red to violet. After stirring at 0°C for 10 minutes, 0.2 ml water was added. The reaction was then worked up by removing the THF in vacuo, dissolving the residue with methylene chloride, drying with magnesium sulfate, filtering and removing the solvent in vacuo to give a dark red solid. A TLC on silica gel with hexane eluant showed three spots. Chromatography of the sample on a thick layer plates of silica gel G with hexane gave three bands. Collection

of the second band and removal from the silica gel with methylene chloride gave 10 mg red material after removal of the solvent. The material was applied to a salt plate with methylene chloride, the solvent evaporated and an IR taken.

IR 3080, 3040, 2960, 2940, 1600, 1560, 1500, 1460, 1270, 1160, 1120, 1060, 935, 840, 815, 780, 770, 740, 700 cm^{-1} .
 Mass Spectrum 70 eV 414-30%, 412-42%, 398-74%, 396-100%, 379-19%, 378-20%, 363-36%, 328-58%, m^* at 384-382 (412-396 m^* calculated 382), 20 eV 414=70%, 412-100%, 398-65%, 396-90%.

Chlorination of 1,8-bis(phenylethynyl)naphthalene

(56). 0.85 ml of an 82.8 mg/ml solution of chlorine in chloroform (70.9 mg, 1 mmoles chlorine) was added dropwise over a period of 3 hours to a stirred solution of 0.3461 gm (1.091 mmoles) 1,8-bis(phenylethynyl)naphthalene at room temperature. The extent of reaction was monitored by TLC on silica gel. After 2 days the number of products had not changed from those present at 3 hours reaction time. The solvent was then removed in vacuo and the residue recrystallized to give 117.4 mg, mp 98-101° C starting material. The mother liquor solvent was removed and the resulting residue chromatographed on a 3.5 x 30 cm column of silica gel packed in hexane. Two components were cleanly separated by

elution with hexane. Band 1, 11.1 mg red powder, mp 148-149.5° C; band 2, 11.8 mg white needles, mp 102° C (IR shows it to be starting material).

Spectral Analysis of Band 1

IR (KBr) 3080, 3060, 1600, 1570, 1500, 1450, 1375, 960, 820, 775, 750, 695 cm^{-1} .

Mass Spectrum 70 eV 402-1.3%, 400-4.2%, 398-6.3%, 365-36%, 364-50.6%, 363-10%, 362-79.5%, 328-33.5%; 20 eV 402-2.6%, 400-6.2%, 398-7.2%, 365-31%, 364-54%, 363-83%, 362-100%, 328-2%.

Mass Spectrum (gross mixture after removing starting material) 70 eV 468-1.1%, 433-11%, 398-95%, 363-100%.

Ozonolysis of $\text{C}_{26}\text{H}_{14}\text{Cl}_2$ (60). A solution of 14.7 mg (3.72×10^{-5} moles) $\text{C}_{26}\text{H}_{14}\text{Cl}_2$ in 200 ml methylene chloride was ozonized at 0° C for 3 minutes with an ozone/oxygen gas stream giving 0.55 mmoles/minutes ozone. After ozonolysis, the solution was allowed to stand at 0° C for 20 minutes. Then 10 ml water and 100 ml methanol were added. After stirring this solution for 10 minutes 1 ml 3N HCl was added. The solvent was then removed in vacuo to give a light yellow solid. This solid was dried overnight at 0.03 torr and room temperature. It was then washed with a small amount of methylene chloride to give 5.9 mg insoluble white flakey material.

IR (KBr) 3500-3100, 3040, 2960, 1705, 1620, 1500, 1460, 1415, 1290, 1200, 1190-1070, 930, 760, 700 cm^{-1} .

The IR was compared to those from authentic samples of naphthoic anhydride and acid and was not identical to either. Mass Spectrum 70 eV 230-100%, 228-75% no heat; 20 eV 230-3%, 128-100% after heating; 70 eV after 5 minutes in sample chamber while heating 230-4.4%, 228-4.4%, 128-100%.

X-ray data collection for 61. Single crystals of 61 can be grown from methylene chloride as long needles with square cross sections. Cubes, roughly 0.08 mm on an edge, were cut from the needles for diffraction work. No crystal decomposition was noticed during the course of the study.

Precession photographs displayed $\bar{1}$ reciprocal lattice symmetry. The space group is $P\bar{1}$. The goniometer head was then transferred to a fully automated Hilger-Watts four circle diffractometer. Lattice constants were determined using $\text{Mo K}\alpha$ (0.7107 Å). The unit cell dimensions are $a = 7.401 \pm 0.003$ Å, $b = 11.383 \pm 0.003$ Å, $c = 11.702 \pm 0.003$ Å, $\alpha = 95.03 \pm 0.05^\circ$, $\beta = 86.32 \pm 0.05^\circ$, $\gamma = 93.51 \pm 0.05^\circ$. The calculated volume is 978.3 Å³ for molecular formula $\text{C}_{26}\text{H}_{16}\text{SCl}_2$.

The intensity data were collected using the stationary-crystal stationary-counter technique with two 5-sec. backgrounds and a 10-sec. peak height. Complete data in

hkl , $\bar{h}kl$, $h\bar{k}l$ and $\bar{h}\bar{k}l$ octants with $\theta \leq 30^\circ$ were collected using Zr filtered Mo K_α radiation. A total of 2808 reflections were judged observed after background and L_p corrections.

The molecular outline was found quite readily by standard heavy atom techniques. Figure 18 is a computer generated drawing of one of the molecules of the centrosymmetric pair. The final R is 0.140 for the 2808 observed reflections.

REFERENCES CITED

1. F. A. L. Anet, J. Amer. Chem. Soc., 86, 458 (1964).
2. K. Conrow, M. E. H. Hauden and D. Davis, J. Amer. Chem. Soc., 85, 1929 (1963).
3. T. J. Barton, Ph.D. Thesis, University of Florida, 1967.
4. R. E. Davis and A. Tulinsky, Tetrahedron Let., 839 (1962).
5. A. Streitwieser, "Molecular Orbital Theory for Organic Chemists", John Wiley & Sons, New York, 1961, p. 277.
6. M. J. S. Dewar, "The Molecular Orbital Calculations for Organic Chemistry", McGraw-Hill, New York, 1969, p. 187.
7. W. von E. Doering and L. H. Knox, J. Amer. Chem. Soc., 76, 3203 (1954).
8. R. M. Roberts, J. C. Gilbert, L. B. Rodewald and A. S. Wingrove, "An Introduction to Modern Experimental Organic Chemistry", Holt, Rinehart and Winston, New York, 1969, p. 308.
9. D. Meuche, H. Struass, and E. Heilbronner, Helv. Chim. Acta, 41, 57 (1958).
10. See Reference 6.
11. See Reference 6, p. 369.
12. E. E. VanTamelen, Tetrahedron Let., 14 (1960).
13. A. J. Levsink, Tetrahedron Let., 1263 (1967).
14. F. A. Cotton and G. Wilkinson, "Advanced Inorganic Chemistry", Interscience John Wiley and Sons, New York, 1967, p. 410.
15. D. W. J. Cruickshank, J. Chem. Soc., 5486 (1961).
16. See Reference 6, p. 432.
17. E. A. V. Ebsworth in "Organometallic Compounds of the Group IV Elements", Vol. 1, A. G. MacDiarmid, Ed., Marcel Dekker, New York, 1968, Chapter 1.
18. See Reference 17, p. 28.

19. V. Weidner and A. Schweig, J. Organomet. Chem., 37, C29 (1972).
20. A. Fahlman, et al., Nature, 210, 4 (1966).
21. M. J. S. Dewar et al., J. Chem. Soc., 2403 (1960), and references therein.
22. H. C. Longuet-Higgins, Trans. Faraday Soc., 45, 173 (1949).
23. C. A. Coulson and T. H. Goodwin, J. Chem. Soc., 2851 (1962).
24. C. A. Coulson and T. H. Goodwin, J. Chem. Soc., 3161 (1963).
25. W. G. Woods, R. A. Carboni and J. D. Roberts, J. Amer. Chem. Soc., 78, 5653 (1956).
26. M. Brookhart, A. Diaz and S. Winstein, J. Amer. Chem. Soc., 88, 3135 (1966).
27. L. Birkofer and H. Heddid, Chem. Ber., 102, 432 (1969).
28. T. J. Barton, W. E. Volz and J. L. Johnson, J. Org. Chem., 36, 3365 (1971).
29. R. Rogido, "1-H Azepins" Organic Chemistry Seminar, Iowa State University, Nov. 20, 1969.
30. L. A. Paquette in "nonbenzenoid Aromatics", J. P. Snyder, ed., Academic Press, New York, 1969, Chapter 5.
31. H. Gunther, Tetrahedron Let., 4085 (1965).
32. E. Vogel and H. Gunther, Angew. Chem. Internat. Ed., 6, 385 (1967).
33. V. J. Traynelis and J. R. Livingston, J. Org. Chem., 29, 1092 (1964).
34. H. Hofmann and H. Westernacher, Angew. Chem. Internat. Ed., 6, 255 (1967).
35. M. J. S. Dewar and N. Trinajstić, J. Amer. Chem. Soc., 92, 453 (1970).
36. J. D. Fitzpatrick, "Synthesis and Chemistry of Cyclobutadiene Irontricarbonyl Complexes", Ph.D. Thesis, University of Texas, 1966.

37. M. P. Cava and M. J. Mitchell, "Cyclobutadiene and Related Compounds", Academic Press, New York, 1967.
38. M. E. Vol'pin, Y. Koreshkov, V. Dulova and D. N. Kursanov, Tetrahedron, 18, 107 (1962).
39. M. E. Vol'pin, Ada. A. Nauk. SSSR ot del Khim. Nauk., 1355 (1961).
40. R. West and R. E. Bailey, J. Amer. Chem. Soc., 85, 2871 (1963).
41. F. Johnson, R. S. Gohlke and W. A. Nasutavicus, J. Organomet. Chem., 3, 233 (1965).
42. W. H. Atwell, D. R. Wyenberg and H. Gilman, J. Org. Chem., 32, 885, (1967).
43. E. H. Braye, W. Hubel and I. Capleir, J. Amer. Chem. Soc., 83, 4406 (1961).
44. Francesco Fringuelli and A. Tatiachi, J. Chem. Soc., 199 (1972).
45. W. Mack, Angew. Chem., 78, 940 (1966).
46. K. E. Schulte, H. Walker and L. Rolf, Tetrahedron Let., 4819 (1967).
47. I. G. M. Campbell, R. C. Cookson, M. B. Hocking and A. N. Hughs, J. Chem. Soc., 2184 (1965).
48. D. R. Weyenberg, H. Topover and G. Nelson, J. Org. Chem., 33, 1975 (1968).
49. R. Calas et al., J. Organomet. Chem., 25, 51 (1968).
50. S. M. King, C. R. Bauer and R. E. Lutz, J. Amer. Chem. Soc., 73, 2253 (1951).
51. C. Paal, Chem. Ber., 17, 2757 (1884).
52. L. Knorr, Chem. Ber., 17, 3863 (1884).
53. L. Knorr, Chem. Ber., 17, 1635 (1884).
54. K. E. Schulte, J. Reisch and W. Herman, Naturwissenschaften, 50, 332 (1963).
55. R. F. Curtix, S. N. Hasnain and J. A. Taylor, Chem. Comm., 365 (1968).

56. O. Hinsberg, Chem. Ber., 43, 901 (1910).
57. H. Prinzbach, Angew. Chem. Internat. Ed., 5, 1039 (1966).
58. H. Prinzbach, R. Fuchs and R. Kitzing, Angew. Chem. Internat. Ed., 7, 67 (1968).
59. H. Gilman, S. G. Cottis and W. H. Atwell, J. Amer. Chem. Soc., 86, 1594 (1964).
60. H. Gilman, S. G. Cottis and W. H. Atwell, J. Amer. Chem. Soc., 86, 5584 (1964).
61. J. G. Zavistoski and J. J. Zuckerman, J. Amer. Chem. Soc., 90, 6612 (1968).
62. N. K. Hota and C. J. Willis, J. Organomet. Chem., 15, 89 (1968).
63. G. O. Schenck et al., Chem. Ber., 95, 1642 (1962).
64. G. O. Schenck, W. Hartmann and R. Steinmetz, Chem. Ber., 96, 498 (1963).
65. G. Märkl and H. Schubert, Tetrahedron Let., 1273 (1970).
66. G. Staffan and G. O. Schenck, Chem. Ber., 100, 3961 (1967).
67. H. M. Rosenberg and P. Serve, J. Org. Chem., 33, 1653 (1968).
68. D. C. Neckers, J. H. Dopfer and H. Wynberg, J. Org. Chem., 35, 1582 (1970).
69. D. C. Neckers, J. H. Dopfer and H. Wynberg, Tetrahedron Let., 2913 (1969).
70. R. M. Kellogg and H. Wynberg, Tetrahedron Let., 5895
71. J. J. Zuckerman and R. Rosenberg, J. Organomet. Chem., 33, 321 (1971).
72. R. Benkeser and R. F. Cunico, J. Organomet. Chem., 4, 284 (1965).
73. E. E. Schweizer and W. E. Parham, J. Amer. Chem. Soc., 82, 4085 (1960).
74. W. E. Parham and R. Koncos, J. Amer. Chem. Soc., 83, 4934 (1961).

75. H. Wynberg, Accts. of Chem. Res., 4, 65 (1971).
76. R. M. Kellogg, J. Dik, H. vanDriel and H. Wynberg, J. Org. Chem., 35, 2737 (1970).
77. H. Wynberg, R. Kellogg, H. vanDriel and G. Beekhuis, J. Amer. Chem. Soc., 89, 3501 (1967).
78. R. M. Kellogg and H. Wynberg, J. Amer. Chem. Soc., 89, 3495 (1967), and references therein.
79. H. vanDriel, R. M. Kellogg, H. Wynberg and J. Buter, J. Amer. Chem. Soc., 89, 3487 (1967).
80. R. M. Kellogg and H. Wynberg, Tetrahedron Let., 5895 (1968).
81. Balwant Singh and E. F. Ulman, J. Amer. Chem. Soc., 89, 6911 (1967).
82. E. E. VanTamelen and G. Whitesides, J. Amer. Chem. Soc., 93, 6129 (1971).
83. H. Wynberg, J. Amer. Chem. Soc., 89, 3487 (1967).
84. W. H. Atwell, D. R. Weyenberg and H. Gilman, J. Org. Chem., 32, 885 (1967).
85. D. Gagnaire and E. Payo-Subiza, Bull. Soc. Chim. France, 2633 (1963).
86. J. C. Clardy, unpublished results, Iowa State University.
87. See Reference 84.
88. D. Trecker, R. Foote, J. Henry and J. McKeon, J. Amer. Chem. Soc., 88, 3021 (1966).
89. D. Seyferth and A. B. Aonin, J. Amer. Chem. Soc., 89, 1468 (1967).
90. T. Sato and Ichiro Moritani, Tetrahedron Let., 3181 (1969).
91. W. E. Haines, G. L. Cook and J. S. Ball, J. Amer. Chem. Soc., 78, 5213 (1956).
92. W. Daview and F. C. James, J. Chem. Soc., 314 (1955).
93. A. Mustafa and S. M. A. D. Zayed, J. Amer. Chem. Soc., 78, 6174 (1956).

94. K. E. Schulte, J. Reich and H. Walker, Chem. Ber., 98, 98 (1965).
95. L. D. Quin, J. G. Bayson and C. G. Moreland, J. Amer. Chem. Soc., 91, 3308 (1969).
96. W. Egan, R. Tang, G. Zon and K. Mislow, J. Amer. Chem. Soc., 93, 6205 (1971).
97. H. H. Jaffé and M. Orchin, "Theory and Applications of Ultraviolet Spectroscopy", John Wiley and Sons, New York, 1962, p. 347.
98. M. King, C. R. Bauer and R. E. Lutz, J. Amer. Chem. Soc., 73, 2253 (1951).
99. I. G. M. Campbell, R. C. Cookson, M. B. Hocking and A. N. Hughs, J. Chem. Soc., 2185 (1965).
100. See Reference 84.
101. W. Mack, Angew. Chem., 78, 940 (1966).
102. P. Bladon et al., J. Chem. Soc. C., 306 (1966).
103. M. K. Orloff and D. D. Fitts, J. Chem. Phys., 38, 2334 (1964).
104. N. L. Allinger and J. C. Tai, J. Amer. Chem. Soc., 87, 2081 (1965).
105. R. Pariser and R. G. Parr, J. Chem. Phys., 21, 767 (1953).
106. H. Morawetz, Science, 152, 705 (1966).
107. J. Bregman, K. Osaki, G. Schmidt and F. Sonntag, J. Chem. Soc., 2021 (1964).
108. D. Weiss, unpublished results, Iowa State University.
109. E. J. Corey, J. Bass, R. LeMahieu and R. Mitra, J. Amer. Chem. Soc., 86, 5579 (1964).
110. H. L. Dryden, J. Amer. Chem. Soc., 76, 2841 (1954), and references therein.
111. L. M. Jackman and S. Sternhall, "N. M. R. Spectroscopy in Organic Chemistry", Pergamon, New York, 1969, p. 276.
112. See Reference 111, p. 336.

113. K. B. Wiberg, J. E. Hiatt and K. Hseih, J. Amer. Chem. Soc., 92, 544 (1970).
114. K. B. Wiberg and J. G. Pfeiffer, J. Amer. Chem. Soc., 92, 553 (1970).
115. K. B. Wiberg, V. Z. Williams and L. E. Friedrich, J. Amer. Chem. Soc., 92, 564 (1970).
116. R. M. Silverstein and G. C. Bassler, "Spectrometric Identification of Organic Compounds", J. Wiley and Sons, New York, 1967, p. 88.
117. See Reference 111, p. 336.
118. J. March, "Advanced Organic Chemistry", McGraw Hill, New York, 1968, p. 593.
119. L. W. Picket, G. Walker and H. France, J. Amer. Chem. Soc., 58, 2296 (1936).
120. See Reference 111, p. 287.
121. V. Georgian and L. Georgian, Tetrahedron, 19, 1219 (1963).
122. J. K. Williams, D. Wiley and B. McKusick, J. Amer. Chem. Soc., 84, 2210 (1962).
123. E. Lustig, J. Chem. Phys., 37, 2725 (1962).
124. See Reference 121.
125. K. B. Wiberg, J. Amer. Chem. Soc., 92, 544 (1970).
126. H. Budzikiewicz, C. Djerassi and D. H. Williams, "Mass Spectrometry of Organic Compounds", Holden-Day, San Francisco, 1967, p. 197.
127. D. D. Roberts, J. Org. Chem., 30, 22 (1965).
128. T. J. Barton, Ph.D. Thesis, University of Florida, 1967.
129. M. Akhtar, T. A. Richards and B. Weedon, J. Chem. Soc., 933 (1959).
130. F. E. Ray, E. Sawicki and O. H. Borin, J. Amer. Chem. Soc., 74, 1241 (1952).
131. See Reference 126, p. 564.

132. K. Nakanishi, "Infrared Adsorption Spectroscopy", Holden-Day, San Francisco, 1962, p. 55.
133. See Reference 128.
134. See Reference 111, p. 285.
135. See Reference 111, p. 293.
136. K. B. Wiberg, B. Andes Hess and A. J. Ashe, "Cyclopropylcarbiny and Cyclobutyl Cations", Department of Chemistry, Yale University, unpublished manuscript, p. 51.
137. F. F. Nelson, Ph.D. Thesis, University of Wisconsin, 1960.
138. See Reference 111, p. 287.
139. See Reference 121.
140. See Reference 136.
141. R. B. Woodward and R. Hoffman, "The Conservation of Orbital Symmetry", Verlag Chemis, Academic Press, Weinheim. Germany, 1970.
142. K. B. Wiberg, V. Z. Williams and L. E. Friedrich, J. Amer. Chem. Soc., 92, 564 (1970).
143. H. Kwart and J. Slutsky, J. Amer. Chem. Soc., 94, 2515 (1972).
144. See Reference 137.
145. H. L. Dryden, J. Amer. Chem. Soc., 76, 2841 (1954).
146. H. L. Dryden and B. E. Burgert, J. Amer. Chem. Soc., 77, 5633 (1955).
147. See Reference 65.
148. G. O. Schenck, W. Hartmann and R. Steinmetz, Chem. Ber., 98, 3854 (1965).
149. H. Scharf, W. Droste and R. Leibig, Angew. Chem. Internat. Ed., 7, 215 (1968).
150. A. F. Vellturo and G. W. Griffin, J. Amer. Chem. Soc., 83, 2725 (1961).

151. G. O. Schenck et al., Chem. Ber., 95, 1642 (1962).
152. G. Doerhoefer, Tetrahedron Let., 4511 (1966).
153. J. A. Barltrop and R. Robson, Tetrahedron Let., 597 (1963).
154. P. deMayo and R. Reid, Proc. Chem. Soc., 54 (1963).
155. J. E. Shields, D. Gavrilovic and J. Kopecky, Tetrahedron Let., 271 (1971).
156. E. J. Corey, J. Bass, R. LeMahieu and R. Mitra, J. Amer. Chem. Soc., 86, 5579 (1964).
157. See Reference 60.
158. See Reference 62.
159. T. J. Barton, J. Witiak and C. McIntosh, unpublished work.
160. E. J. Corey, F. A. Carey and A. E. Winter, J. Amer. Chem. Soc., 87, 934 (1965).
161. C. Eaborn, "Organosilicon Compounds", Butterworths, London, 1960.
162. See Reference 8, p. 196-200.
163. R. Huisgen and K. Herbig, Ann. Chem., 688, 98 (1965).
164. R. Huisgen, K. Herbig and M. Morikawa, Chem. Ber., 100, 1107 (1967).
165. T. J. Barton, A. J. Nelson and J. Clardy, J. Org. Chem., 37, 895 (1972).
166. M. Stiles and R. G. Miller, J. Amer. Chem. Soc., 82, 3802 (1960).
167. M. Stiles and R. G. Miller, J. Amer. Chem. Soc., 85, 1798 (1963).
168. L. Friedman and F. M. Loguilo, ibid., 85, 1549 (1963).
169. R. Knorr, Chem. Ber., 98, 4038 (1965).
170. S. Yaroslavsky, Chem. Ind. (London), 765 (1965).

171. F. M. Beringer and S. J. Huang, J. Org. Chem., 29, 445 (1964).
172. E. McNelis, J. Org. Chem., 28, 3188 (1963).
173. R. W. Hoffmann, "Dehydrobenzene and Cycloalkynes", Academic Press, New York, 1967, p. 77.
174. See Reference 173, p. 210.
175. See Reference 17, p. 51.
176. C. D. Campbell and C. W. Rees, Proc. Chem. Soc., 296 (1964).
177. H. Gilman, S. G. Cottis and W. H. Atwell, J. Amer. Chem. Soc., 86, 5584 (1964).
178. E. A. Braye, I.U.P.A.C. Symposium on Organo-Phosphorus Compounds, Heidelberg, 1964.
179. G. Märkl and H. Hauptmann, Tetrahedron Let., 3257 (1968).
180. J. Reisch and K. E. Schulte, Angew. Chem., 73, 241 (1961).
181. K. E. Schulte, J. Reisch and L. Horner, Angew. Chem., 72, 920 (1960).
182. K. E. Schulte, J. Reisch and L. Horner, Angew. Chem., 72, 920 (1960).
183. K. E. Schulte and G. Bohn, Arch. Pharm., 297, 179 (1964).
184. K. E. Schulte, G. Rucker and W. Meinders, Tetrahedron Let., 659 (1965).
185. R. F. Curtis, S. N. Hasmain and J. A. Taylor, Chem. Comm., 365 (1968).
186. W. Mack, Angew. Chem. Internat. Ed., 5, 896 (1966).
187. H. W. Whitlock and P. E. Sandvick, J. Amer. Chem. Soc., 88, 4525 (1966).
188. T. J. Barton and R. G. Zika, J. Org. Chem., 53, 1729 (1970).

189. L. Brandsma and J. F. Arens, Rec. Trav. Chim., 80, 237 (1967).
190. K. E. Schulte, H. Walker and L. Rolf, Tetrahedron Let., 4819 (1967).
191. D. W. H. MacDowell and A. T. Jefferies, J. Org. Chem., 35, 871 (1970) and references therein.
192. T. J. Barton, A. J. Nelson and J. C. Clardy, J. Org. Chem., 36, 3885 (1971).
193. J. Ipaktschi and H. A. Staab, Tetrahedron Let., 4403 (1967).
194. B. Bosenbroeck and H. Schechter, J. Amer. Chem. Soc., 89, 7111 (1967).
195. P. R. Houlton and W. Kemp, Tetrahedron Let., 1045 (1968).
196. See Reference 194.
197. P. Banard, J. Chem. Soc., 4577 (1957).
198. V. Boekelheide and G. K. Vick, J. Amer. Chem. Soc., 78, 653 (1956).
199. P. D. Gardner and R. J. Thompson, J. Chem. Soc., 22, 36 (1957).
200. M. P. Cava and R. H. Schlessinger, Tetrahedron, 21, 3051 (1965).
201. See Reference 194.
202. R. Pettit, J. Amer. Chem. Soc., 82, 1972 (1960).
203. F. A. Cotton and G. Wilkinson, "Advanced Inorganic Chemistry", John Wiley and Sons, New York, 1967, p. 538.
204. J. March, "Advanced Organic Chemistry; Reactions, Mechanisms, and Structures", McGraw-Hill, New York, 1968, pp. 563 to 564.
205. V. Boekelheide and C. E. Larrabee, J. Amer. Chem. Soc., 72, 1245 (1960).
206. H. O. House, "Modern Synthetic Reactions", W. A. Benjamin, Inc., New York, 1965, p. 9.

207. See Reference 206, p. 92-100.
208. G. Naville, H. Strauss and E. Heilbronner, Helv. Chem. Acta, 43, 1221 (1960).
209. H. L. Slates and N. L. Wendler, J. Med. Chem., 8, 886 (1965).
210. R. H. Schlessinger and A. G. Schultz, J. Amer. Chem. Soc., 90, 1676 (1968).
211. E. D. Bergmann and I. Agranat, J. Org. Chem., 31, 2407 (1966).
212. J. Mitchell, R. Topson and K. Vaughan, J. Chem. Soc., 2526 (1962).
213. R. Ellingboe and M. Melby, Chem. Abst., 52p:12899g (1953).

ACKNOWLEDGEMENTS

My deep respect is owed by father and mother who both instilled in me a sense of security and appreciation of knowledge. They certainly take part in spirit in all I do. My mentor, Thomas J. Barton, has provided me with the confidence necessary to take part in professional discussion and investigation. His spontaneous exchange of ideas while having hands on the "tiller" made the coming professionalism an enjoyable experience. The ribald antics of the people of the group has quieted in recent years, but I will miss those knights of roast pig who make even the gloomiest reaction a chuckle. Bob Rogido deserves special thanks from me for his quiet suggestions and down-to-earth manner. The X-ray work was done under the supervision of Jon Clardy. His work is appreciated.

My wife in doing her best to keep me happy has created many a talisman for me to grasp in moments of superstitious thought. My wee son, who senses the final phase of our life in Ames, has given me the happiness of being "hey dad"; oh, to be young all of your life.

The author acknowledges partial financial support from a N.A.S.A. Fellowship.

APPENDIX

Overlap function of $2p_z$ with $3d_{xz}$

$$\psi_{2p_z} = \frac{1}{4\sqrt{2\pi}} \left(\frac{z}{a_0}\right)^{3/2} \sigma_1 e^{-\frac{\sigma_1}{2}} \cos \theta_1$$

$$\psi_{3d_{xz}} = \frac{\sqrt{2}}{81\sqrt{\pi}} \left(\frac{z}{a_0}\right)^{3/2} \sigma_2^2 e^{-\frac{\sigma_2}{3}} \sin \theta_2 \cos \theta_2 \cos(\phi + k)$$

where k is the angle of displacement of the d_{xz} orbital from the internuclear axis

$$\int_{-\frac{\pi}{2}}^{\frac{\pi}{2}} \psi_{2p_z} \psi_{3d_{xz}} d\tau = S_{12}$$

$$S_{12} = \int_{-\frac{\pi}{2}}^{\frac{\pi}{2}} \frac{1}{4\sqrt{2\pi}} \left(\frac{z}{a_0}\right)^{3/2} \sigma_1 e^{-\frac{\sigma_1}{2}} \cos \theta_1 \frac{\sqrt{2}}{81\sqrt{\pi}} \left(\frac{z}{a_0}\right)^{3/2} \sigma_2^2 e^{-\frac{\sigma_2}{3}} \sin \theta_2 \cos \theta_2 \cos(\phi + k) d\sigma_1 d\sigma_2 d\theta_1 d\theta_2 d\phi$$

$$K_1 = \frac{1}{4\sqrt{2\pi}} \left(\frac{z}{a_0}\right)^{3/2} \quad K_2 = \frac{\sqrt{2}}{81\sqrt{\pi}} \left(\frac{z}{a_0}\right)^{3/2}$$

$$I_1 = \int \sigma_1 e^{-\frac{\sigma_1}{2}} d\sigma_1$$

$$I_2 = \int \sigma_2^2 e^{-\frac{\sigma_2}{3}} d\sigma_2$$

$$I_3 = \int \cos \theta_1 d\theta_1$$

$$I_4 = \int \cos \theta_2 \sin \theta_2 d\theta_2$$

$K_1 K_2 I_1 I_2 I_3 I_4 = S_{\pi\pi}$ = overlap at zero displacement

$$\text{Let } k = \frac{\pi}{N}$$

$$S_{12} = S_{\pi\pi} \int_{-\frac{\pi}{2}}^{\frac{\pi}{2}} \cos(\phi + \frac{\pi}{N}) d\phi$$

$$= S_{\pi\pi} \left[\sin\left(\frac{\pi}{2} + \frac{\pi}{N}\right) - \sin\left(\frac{3\pi}{2} + \frac{\pi}{N}\right) \right]$$

$$= S_{\pi\pi} \left[\sin\left(\frac{\pi}{2} - \frac{\pi}{N}\right) + \sin\left(\frac{\pi}{2} - \frac{\pi}{N}\right) \right]; \quad \cos \frac{\pi}{N} = \sin\left(\frac{\pi}{2} - \frac{\pi}{N}\right)$$

$$S_{12} = S_{\pi\pi} 2 \cos \frac{\pi}{N} = S_{\pi\pi} \cos k \quad \text{Q.E.D.}$$